

Fox Thermal

THERMAL MASS FLOW METER
& TEMPERATURE TRANSMITTER



Model FT3



Notice

This publication must be read in its entirety before performing any operation. Failure to understand and follow these instructions could result in serious personal injury and/or damage to the equipment. Should this equipment require repair or adjustment beyond the procedures given herein, contact the factory at:

**FOX THERMAL INSTRUMENTS, INC.
399 RESERVATION ROAD
MARINA, CA 93933
TELEPHONE: 831-384-4300
FAX: 831-337-5787
EMAIL: SERVICE@FOXTHERMAL.COM**

**Download Technical Data Sheets from our website:
www.foxthermal.com**

Fox Thermal Instruments (Fox Thermal) believes that the information provided herein is accurate; however, be advised that the information contained herein is NOT a guarantee for satisfactory results. Specifically, this information is neither a warranty nor guarantee, expressed or implied, regarding performance, merchantability, fitness, or any other matter with respect to the products; nor recommendation for the use of the product/process information in conflict with any patent. Please note that Fox Thermal reserves the right to change and/or improve the product design and specification without notice.



Fox Thermal FT3 Manuals:

- Fox Thermal FT3 Data Logger Manual
- Fox Thermal FT3 Calibration Validation User's Guide
- Fox Thermal FT3 RS485 Modbus Manual
- Fox Thermal FT3 HART Manual
- Fox Thermal FT3 View™ Software Manual

All Fox Thermal Manuals and software available in English only.

Table Of Contents

1. Introduction	Page 4
2. Installation (Mechanical)	Page 8
a. Insertion Type	Page 8
b. Inline Type	Page 12
3. Wiring (Electrical)	Page 14
a. General	Page 14
b. Signal Wiring	Page 14
c. Input Power	Page 16
d. Alarm Wiring	Page 21
e. Remote Switch	Page 23
f. Remote Wiring	Page 24
4. Operation (Standard Operation)	Page 26
a. Start Up	Page 26
b. Display Screens	Page 27
c. Engineering Screens	Page 28
d. Programming	Page 29
e. Menu Trees	Page 54
5. Maintenance	Page 60
a. Troubleshooting	Page 63
6. Dimensions	Page 70
7. Appendices	Page 78
a. Specifications	Page 78
b. Agency Approvals	Page 80
c. FT3 with 2 Gas Curves	Page 82
d. Installation Variations	Page 86
e. Returning your meter	Page 88
8. Warranty	Page 89
9. Glossary of Terms and Abbreviations	Page 90
10. Index	Page 92

Introduction

Thank you for purchasing the Model FT3 Thermal Gas Mass Flow Meter and Temperature Transmitter from Fox Thermal. The Model FT3 is one of the most technically advanced flow meters in the world. Extensive engineering effort has been invested to deliver advanced features, accuracy measurement performance and outstanding reliability.

This Instruction Manual contains the electrical and mechanical installation instructions as well as details for programming, maintaining and troubleshooting the meter.

This manual is divided into the following sections: Introduction, Installation, Wiring, Operation, Maintenance, Troubleshooting, Appendices, Glossary and Index.

Theory of Operation

The Model FT3 is an innovative Thermal Mass Gas Flow Meter and Temperature Transmitter. It is microprocessor-based and field programmable. The FT3 thermal sensor operates on the law that gases absorb heat. A heated sensor placed in an air or gas stream transfers heat in proportion to the stream's mass velocity. There are two sensor elements connected to a balanced bridge circuit. One sensor element detects the gas temperature and a second element is maintained at a constant temperature above the gas temperature. The energy applied to the heated sensor to maintain a constant temperature differential (constant ΔT) is directly proportional to the mass flow velocity. The FT3 flow meter maintains accurate flow measurement over a large temperature and pressure range.

Mass Flow

The Model FT3 measures mass flow; an advantage over other flow meters which measure volumetric flow rate. Volumetric flow is incomplete because temperature and pressure are unknown and must be measured separately. For example, the mass flow of a gas depends on its temperature and pressure. As temperature and pressure changes, the gas volume changes but not its mass. Therefore a device measuring mass flow is independent of temperature and pressure. The Model FT3 provides a direct measurement of gas flow in Mass units (kg/hr, lb/hr), standard units (SCFM, SLPM) or normal units (NM³/hr, NLPM) with no additional temperature or pressure measurements required.

Calibration Validation

Fox Thermal has developed a method to validate the calibration of the flow meter in the field. This method is called Calibration Validation and it is made up of two distinct tests: CAL-V™ and Zero CAL-CHECK®. The goal of Calibration Validation is to provide operators with the ability to verify that the meter is capturing accurate data at scheduled recalibration times - or at any time - instead of sending the meter back to the factory for recalibration.

By performing CAL-V™ in the field, operators can verify that the meter is running accurately by testing the functionality of the sensor and its associated signal processing circuitry. This test can be done in the pipe and in normal processing conditions. The second test, Zero CAL-CHECK®, ensures the effectiveness and sensibility of the sensor at a "no flow" condition.

Introduction

Flow Calibration

The Fox Thermal Calibration Lab maintains instrument calibration records on every flow meter. This data can also be accessed by a computer using FT3 View™ software within the instrument. Computer-generated calibration documents describe specific instrument details that can be sorted by serial number, tag number or customer purchase order.

Calibration files include details on process conditions, calibration fluid, line size and other information. All NIST-traceable equipment utilized for the calibration procedure is identified, as is the calibration history of all reference equipment. In addition to the Calibration Certificate, a certified flow table that correlates current outputs with scaled units of flow is produced for each calibrated device.

I/O Description

The FT3 features two galvanically isolated 4-20mA analog outputs, one isolated digital output that can be used for frequency or alarm, one programmable contact input and a USB connection for communication with a computer.

The first 4-20mA output is for flow rate. The second 4-20mA output can be configured either for flow rate or process gas temperature. Both 4-20mA outputs can be scaled by the user. The frequency output is programmable to represent flow rate and can be scaled for maximum flow/maximum frequency, units-per-pulse or pulse-per-units. The maximum frequency is 100 Hz. An isolated 24VDC output power option is provided for use with these outputs. It can supply a 42mA maximum total load (do not use for other external devices). FT3 View™ interfaces to the USB port and is a free Fox Thermal PC-based software program that displays flow meter readings and permits flow meter configuration. Industry standard communication options are available including HART or RS485 Modbus. Only one of these options can be provided in a single FT3 flow meter.

FT3 Optional Display and Configuration Panel

The configuration panel allows the user to change a variety of settings in the FT3. The display is 2 lines x 16 characters with 4 mechanical and 4 IR (infrared) buttons. The IR and mechanical (push) buttons perform the same function but the IR buttons can be used without opening the cover. The IR buttons can be calibrated (p. 53) for better operation in the field or disabled (p. 52) when the meter is used in snow or ice in order to avoid false key detection.

Fig. 1.1: FT3 Optional Display and Configuration Panel

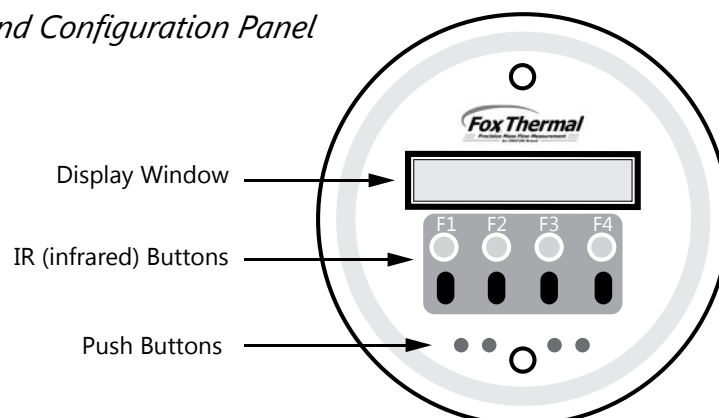

Introduction

FT3 Functional Diagram

An optional on-board display is available to view flow rate, total flow, elapsed time, process gas temperature and alarms. The display is also used in conjunction with the Configuration Panel for field configuration of flow meter settings such as 4-20mA scaling, pulse output frequency scaling, pipe area, zero flow cutoff, flow filtering or damping, display configurations, diagnostics and alarm limits.

Fig. 1.2: FT3 Functional Diagram

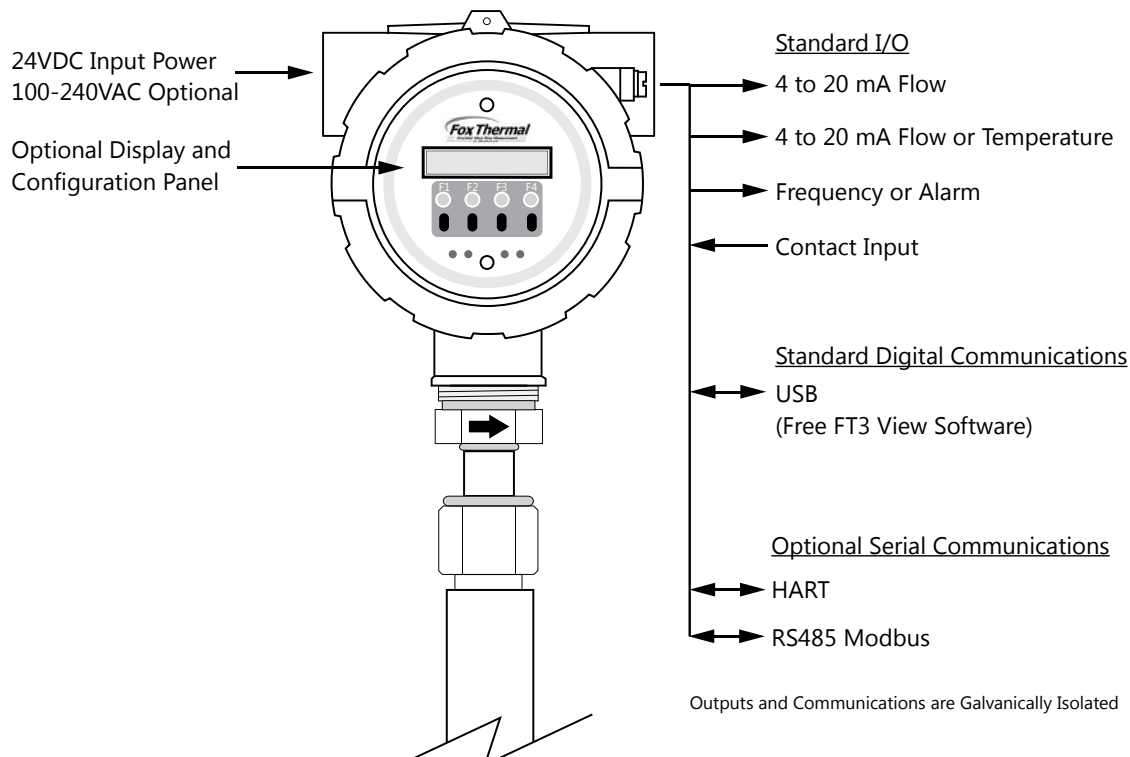

Introduction

Scope

This section describes how to install the Fox Thermal Model FT3 Flow Meter and how to get started. Installation methods will vary according to the flow meter type (insertion or inline).

For Insertion Types:

1. Determine lateral position on the pipe
2. Sensor installation depth
3. Sensor orientation in relation to sensor length and direction of flow
4. Proper tightening of compression fitting for mounting meter

For Insertion type meters with FC10 Flow Conditioners:

Please refer to Document #107679, FC10 Installation Instructions for more information about how to install insertion meters with the FC10 Flow Conditioners.

For Inline Types:

1. Determine lateral position on the pipe
2. Flow body orientation in relation to direction of flow in pipe
3. Proper tightening of compression fitting

Installation procedures must be performed using a combination of the end user's best engineering practices, in compliance with local codes, and manufacturer's recommendations.



General Precautions

The following general precautions should be observed:

1. Exercise care when handling the flow meter to avoid damaging the probe, sensor or enclosure.
2. Close any unused conduit openings in the enclosure with plugs certified for your application.
3. The enclosure covers must be closed except during installation.
4. Mounting FT3 in direct sunlight can cause the temperature inside the enclosure to increase beyond design limits, resulting in failure of LCD display and reduced component life. It is recommended that a sunshade be installed to avoid direct sunlight.
5. Ensure the flow direction arrow points in the direction of flow.
6. Do not install the FT3 enclosure near an igniter, igniter-controller or switching equipment.
7. Do not install an external power supply in a cabinet containing an igniter controller or switching equipment.
8. Ensure that good engineering practices and applicable industry codes are followed throughout the installation process.
9. For accurate flow measurement: review flow meter placement instructions before installation to ensure a proper flow profile in the pipe.

Installation

Instructions for Insertion Flow Meter Lateral Placement

Install the Model FT3 Insertion style flow meter so that it is far enough away from bends in the pipe, obstructions, or changes in line sizes to ensure a consistent flow profile. Fifteen diameters of straight pipe upstream and ten downstream are recommended.

For example, a 2" pipe would require 30" upstream and 20" downstream, but a 4" pipe would require 60" upstream and 40" downstream.



NOTE! The probe diameter is 1/2".

NOTE! Fox Thermal 1/4" meters require 6" of straight pipe upstream and downstream of the meter's inlet and outlet.

NOTE! Fox Thermal flow meters can be mounted in either horizontal or vertical pipes.

Fig. 2.1: Upstream and Downstream Pipe IDs for Insertion Meters

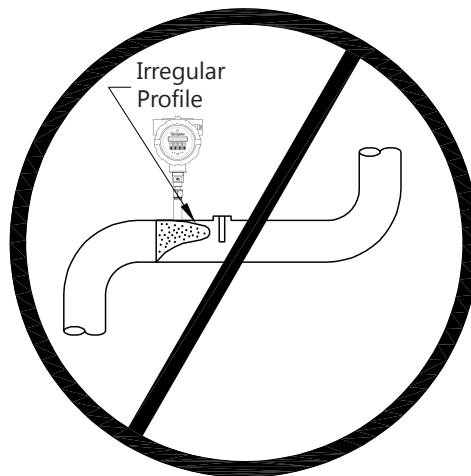
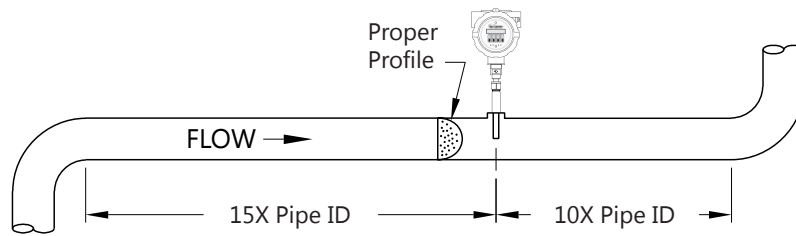

Installation

Installation Depth

The installation depth of the sensor in the pipe is dependent on the pipe size. To get the most accurate reading, proper placement of the sensor window within the pipe is necessary. As shown in Fig 2.2, the end of the sensor window should be 0.87" past the center line of the pipe.

Fig. 2.2: Cross Section of Insertion Sensor Depth in Pipe

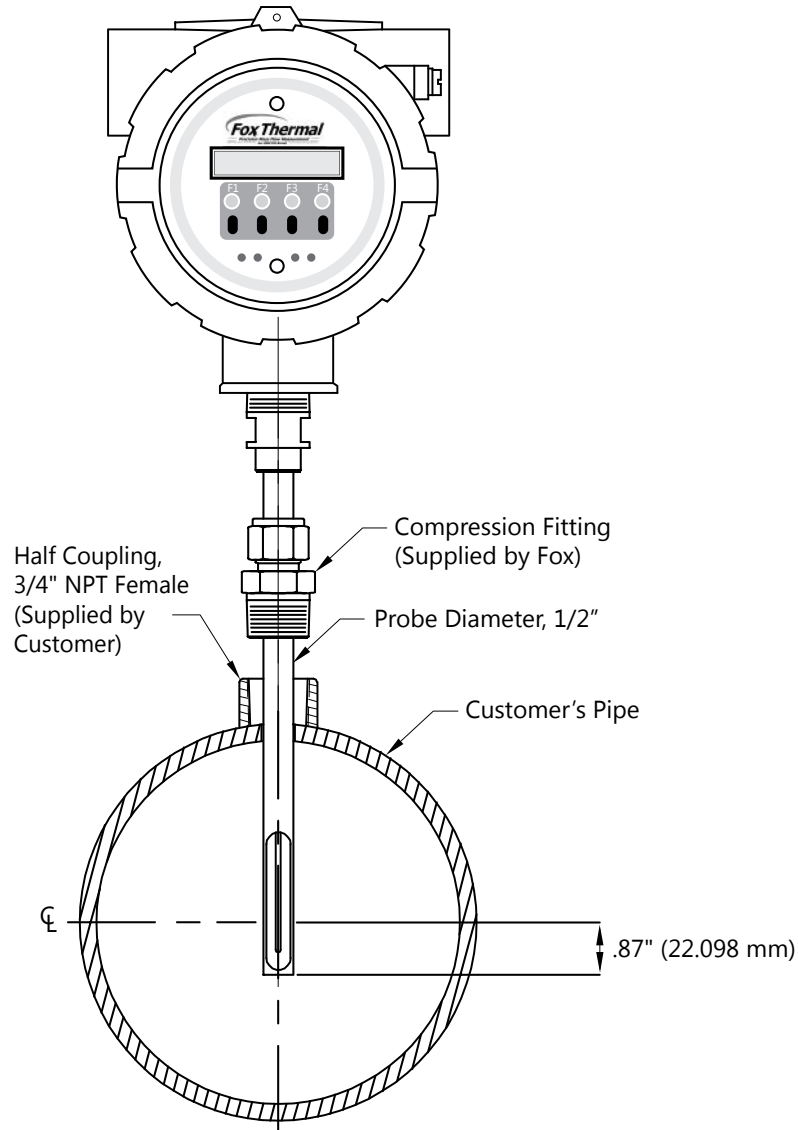

Specific Conditions of Use:

- The flameproof joints of the equipment are not intended to be repaired. Consult manufacturer if dimensional information on the flameproof joints is necessary.
- Follow the manufacturer's instructions to reduce the potential of an electrostatic charging hazard.

Installation

Fig. 2.3: Orientation of Insertion Type Flow Meter

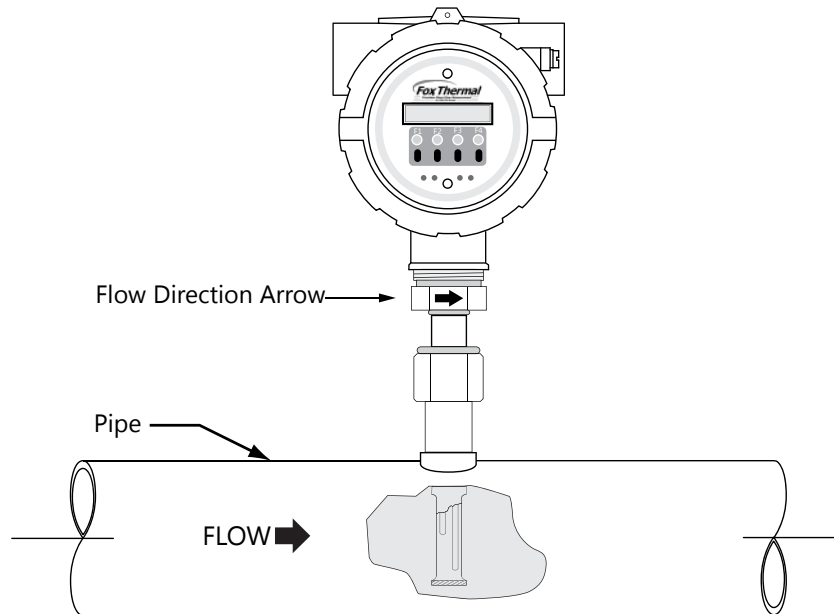

NOTE! Some flow meters are shipped with the sensor elements that are offset (see figure 2.4). Others are shipped with sensors that have equal length elements (see figure 2.5). The sensor type supplied was selected at the factory to be the best suited for your application. Follow the appropriate sensor orientation instructions.

Unequal Length Sensor Elements

Install the shorter sensor element upstream from the longer one.

Fig. 2.4: Unequal Length Sensor Elements

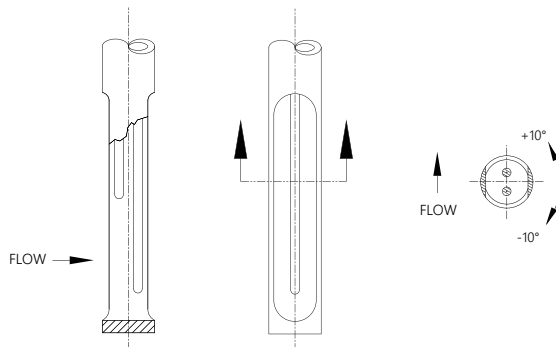

Installation

Equal Length Sensor Elements

Install flow meter with *both sensor elements* facing the flow stream within $\pm 10^\circ$.

Fig. 2.5: Equal Length Sensor Elements

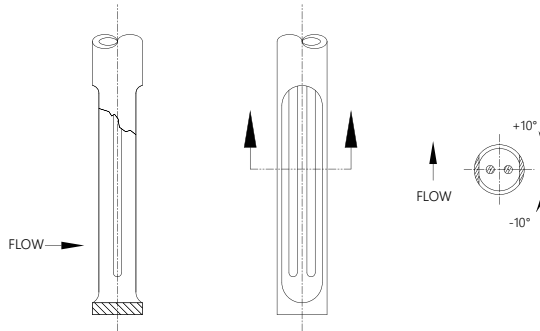

Insertion Mounting Instructions - Compression Fittings

The Model FT3 is mounted through a $\frac{3}{4}$ " hole and a $\frac{3}{4}$ " female NPT half coupling provided in the customer's pipe. Insertion style flow meters are not designed for use in pipes smaller than $1\frac{1}{2}$ ".

- Install the compression fitting into the $\frac{3}{4}$ -inch female NPT half coupling.
- When installing in a 2" pipe or larger, install the end of the probe 0.87" past the center line of the pipe and tighten the compression fitting nut (refer to figure 2.2 on p. 9).
- When installing into a $1\frac{1}{2}$ " pipe carefully install the probe into the pipe until it touches the opposite wall and pull back 0.1". Tighten the compression fitting nut.



CAUTION! Once the compression fitting is locked onto the probe, the probe can be removed or rotated, but the insertion depth is locked in place.



NOTE! Do not overtighten compression fitting.

Fig. 2.6: Proper Tightening of the Compression Fitting Nut

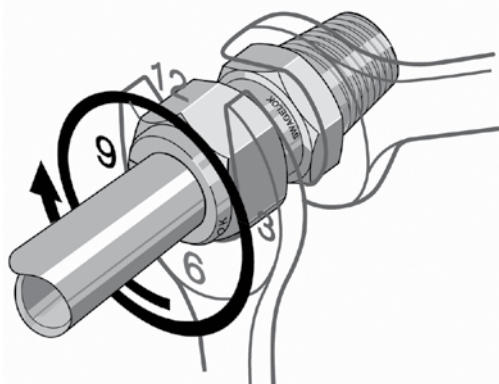

While holding the fitting body steady, tighten the nut one and one-quarter turn to the 9 o'clock position.

Installation

Instructions for Inline Flow Meter Placement

Install the Model FT3 Inline style flow meter so that it is far enough away from bends in the pipe, obstructions, or changes in line sizes to ensure a consistent flow profile. Eight diameters of straight pipe upstream and four downstream are recommended (for ¼" meters: 6" (152 mm) of straight, unobstructed pipe upstream and downstream are required).

For example, a 2" pipe would require 16" upstream from the edge of the flow body and 8" downstream from the other end of the flow body, whereas a 4" pipe would require 32" upstream and 16" downstream.

The Model FT3 is welded, threaded or flanged to the customer's pipe. Care should be taken to ensure that the diameter of the mating pipe is the same diameter as the Model FT3 flow body or errors in flow readings can occur. The installation procedure should be a combination of the end user's best engineering practices, in compliance with local codes, and the manufacturer's recommendations.

See Figure 2.7 for a detailed look at upstream and downstream pipe diameters for inline meters.

Fig. 2.7: Upstream and Downstream Pipe IDs for Inline Meters

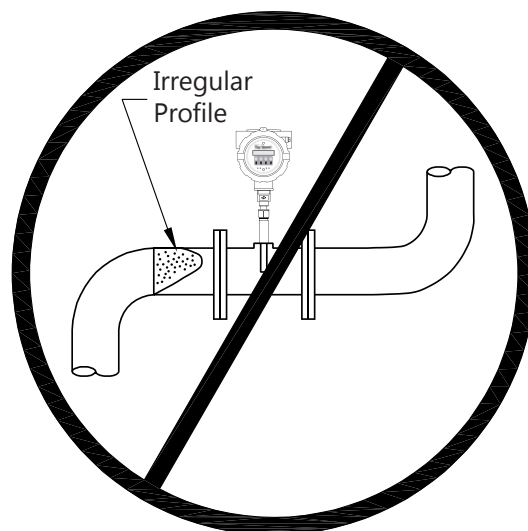
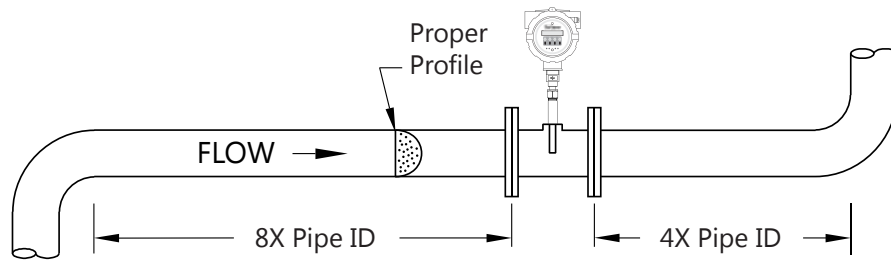

Installation

Inline Orientation

Install the flow body so that the engraved arrow on the fitting and the arrow on the flow body are pointing with the direction of flow.

Fig. 2.8: Orientation of an Inline Meter - Directional Arrows

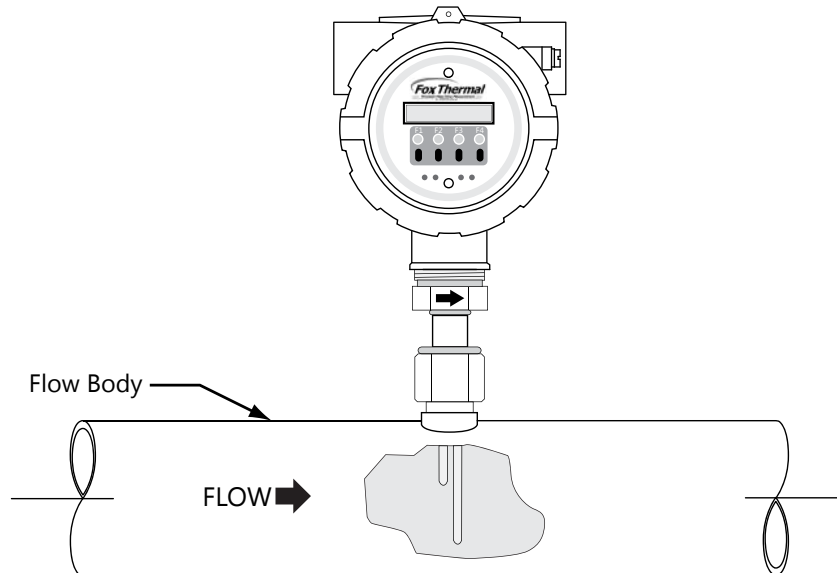

Tightening Compression Fittings

The compression fitting has been placed according to the proper depth in the flow body by Fox Thermal factory technicians. After the flow body has been correctly fitted to the process pipe, the compression fitting may need to be tightened correctly (see figure 2.6 on p. 11).



NOTE!

- Refer to the Fox Thermal FT3 Calibration Validation User's Guide for information on setting the field baseline for Zero CAL-CHECK® tests if you plan to perform these tests in the pipe.
- Please save the PVC sensor cover that was shipped with your meter. It will be needed to perform Zero CAL-CHECK® tests out of pipe.



Wiring

Wiring Instructions

Wire the FT3 by opening the rear enclosure cover, bringing customer supplied wires in through the conduit openings and connecting to the terminal blocks. The FT3 has two conduit openings to maintain separation between AC input power and output signal wiring. To eliminate the possibility of noise interference, use a separate conduit for AC power and cut all wires short for a minimum service loop.



Wiring Precautions

- **WARNING - DO NOT OPEN THE ENCLOSURE WHEN ENERGIZED OR AN EXPLOSIVE ATMOSPHERE IS PRESENT.**
- All plumbing and electrical installations of flow meters must be in compliance with local codes, the end user's best engineering practices, and manufacturer's recommendations.
- An external power disconnect and 16A over-current protection are required for the AC and DC powered FT3.
- Do not install the FT3 enclosure near an igniter, igniter-controller or switching equipment.
- Do not install an external power supply in a cabinet containing an igniter controller or switching equipment.
- This flow meter contains components that can be damaged by static electricity. You must discharge yourself by touching a grounded steel pipe or other grounded steel material prior to working inside this flow meter.
- For the remote sensor option, the serial number of the electronics enclosure must match the remote sensor probe.
- Close any unused entries using suitably certified plugs

Power Wiring

For power wiring, use stranded copper wire, no larger than 16-gauge. If an external 24VDC power source is used, twisted pair shielded cable is recommended. Supply connection wiring must be rated for at least 90°C.

Grounding

The enclosure must be properly grounded with a quality earth ground. 16 gauge, stranded wire is recommended.

Signal Wiring

For signal wiring, the recommended wire gauge is 18 to 22 AWG. Always use twisted pair shielded cable. The cable shield should not be connected at the flow meter, it should be connected at the power supply AC ground terminal or instrumentation AC ground. Do not route the power and signal wires in the same conduit. Power wires must enter left-hand conduit entry. Signal and remote sensor (where applicable) must enter right-hand conduit entry.

Wiring



Serial Communication Wiring

If you have purchased communications options, please refer to one of the following appropriate Fox Thermal Instruction Manuals:

- Fox Thermal FT3 RS485 Modbus Manual
- Fox Thermal FT3 HART Manual

FT3 Wiring

Fig. 3.1: FT3 Wiring

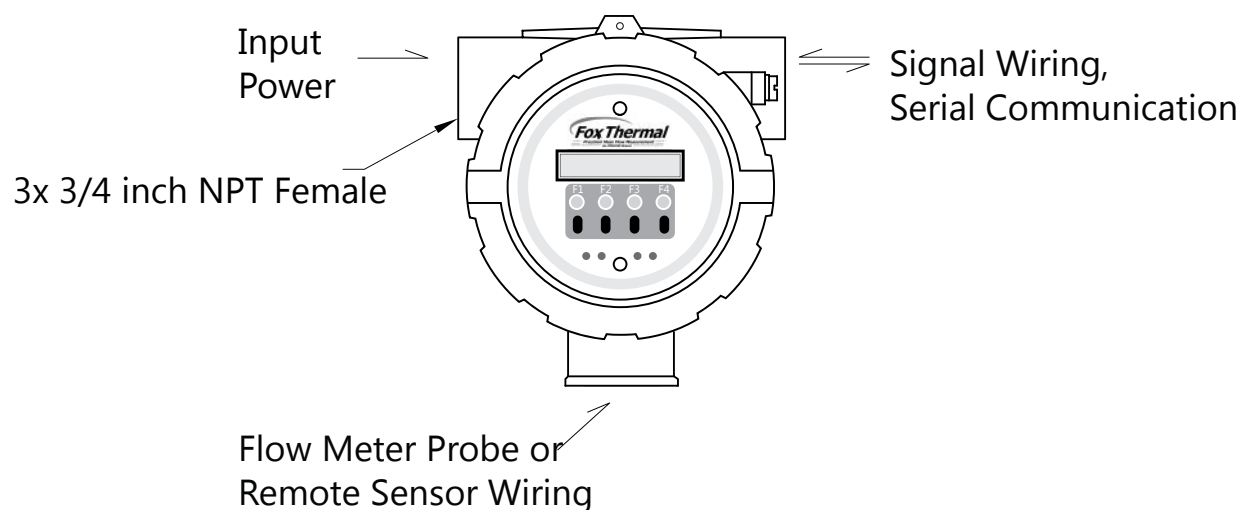

NOTE! Remote wiring is only required when the Remote Electronics options is provided. Five wire shielded cable required, the recommended wire gauge is 18 AWG. Make sure that the cable length does not exceed 100 feet and the wire resistance does not exceed one ohm. Do not connect the cable shield at the electronics enclosure end.

Serial numbers: If you have more than one meter, you must ensure that the serial numbers of the probe/J-Box, remote electronics, housing, and/or flow body match one another. These items have been manufactured and calibrated to operate as a unit and cannot be mismatched.

Installation wiring: Obtain the correct length for the FT3 power and signal wires using one of these methods:

- Trim the wires to extend 2.5 inches out of the enclosure after the conduit and wires are routed to the FT3 (preferred method).
- Trim the wires to extend 6 inches from the end of the conduit before it is attached to the FT3.



Wiring

Power Input Requirements: 24VDC Supply

External DC power supply must provide 24VDC ± 10%, at 0.7 Amps minimum.

The enclosure must be properly grounded with a quality earth ground. Sixteen (16) gauge, stranded wire, is recommended for power and earth ground.

Fig. 3.2: Connections for 24VDC Supply

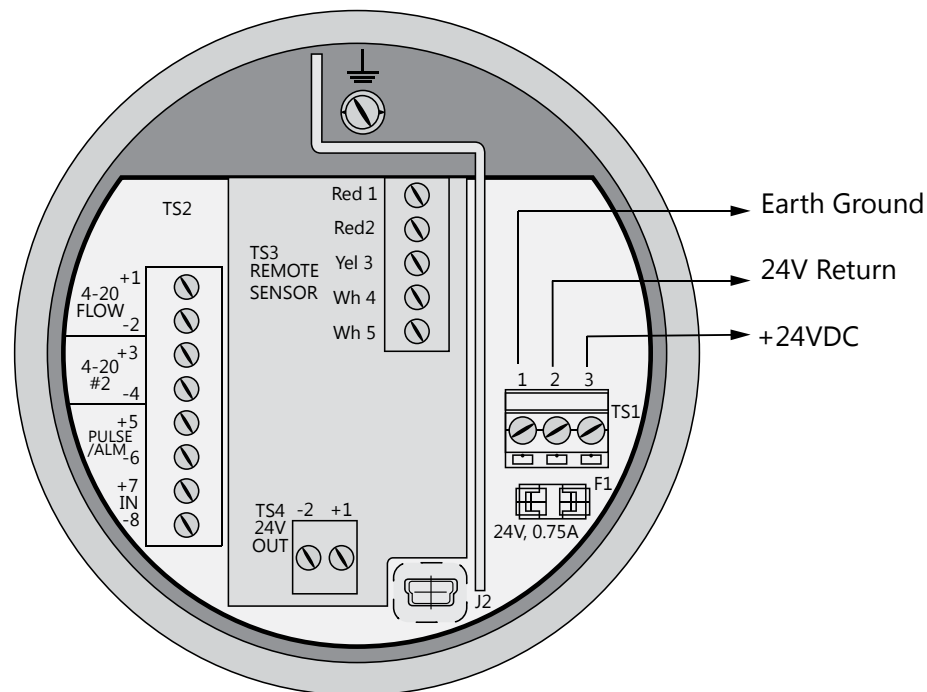

WIRING



CAUTION!

- Supply connection wiring must be rated for at least 90°C.



NOTE! A power failure or resetting the total will cause the Contract Time to change. Data Logger with a Real Time Clock (RTC) option should be used to avoid this.



Wiring

Power Input Requirements: 100 to 240VAC Supply

If the FT3 has the AC power supply option, the AC power must provide 100 to 240VAC -15% / +10% (85 to 264VAC) at 0.2 Amps minimum.

The enclosure must be properly grounded with a quality earth ground. Sixteen (16) gauge, stranded wire, is recommended.

Fig. 3.3: Connections for optional AC Power

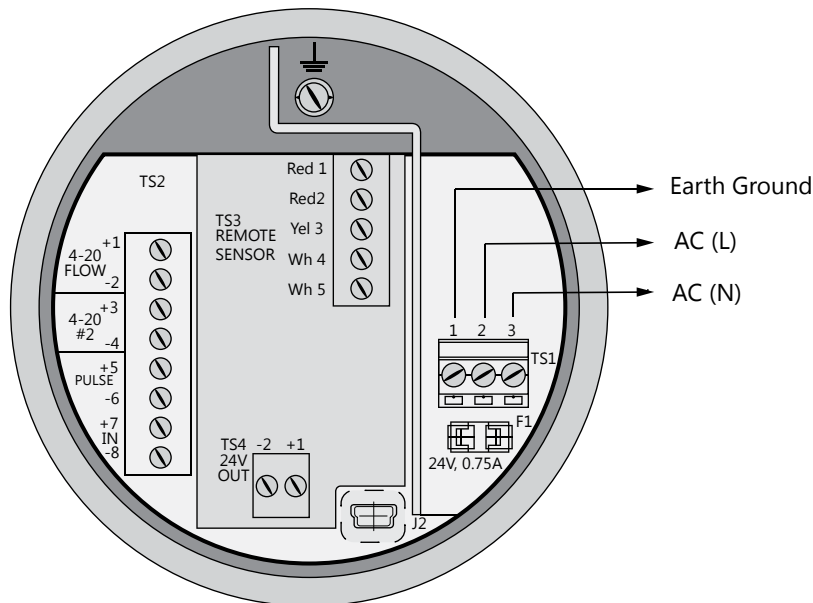

WIRING



CAUTION!

- Supply connection wiring must be rated for at least 90°C.



Wiring

4-20mA Output Wiring: Customer-Supplied Power Source

Bring the 4-20mA wiring in through the right-hand conduit hub. Connect FLOW RATE 4-20mA wiring to TS2, 1(+) & 2(-). Connect 4-20mA output #2 wiring to TS2, 3(+) & 4(-).



CAUTION! When using the 4-20mA output to control equipment in a failsafe application, see the wiring configuration on p. 20.

Fig. 3.4: 4-20mA Output Wiring for Customer-Supplied Power Source

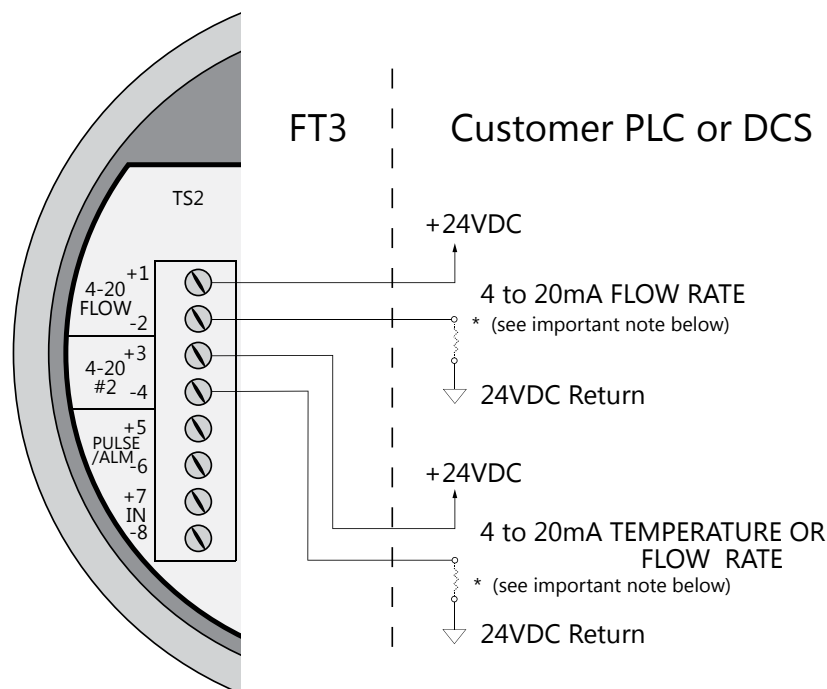

NOTE!

The load resistor on the Fox Thermal Flow Meter 4-20mA signal is typically 250 ohms and is located in or at the customers PLC or DCS. A 250 ohm resistor in the 4-20mA line will result in a 1 to 5VDC signal to the PLC or DCS. Some PLC/DCS equipment has the load resistor built in to the unit; please refer to the PLC/DCS technical manual. **Do not exceed a 600 ohm load on the Fox Thermal Flow Meter 4-20mA signal.**

WIRING

Wiring



4-20mA Output Wiring: Loop Power Provided by FT3

Bring the 4-20mA wiring in through the right-hand conduit hub. Connect the 4-20mA wiring to terminal blocks TS2 and TS4 as shown in the diagram below.

CAUTION! When using the 4-20mA output to control equipment in a failsafe application, see the wiring configuration on p. 20.

Fig. 3.5: 4-20mA Output Wiring for Loop Power Provided by FT3

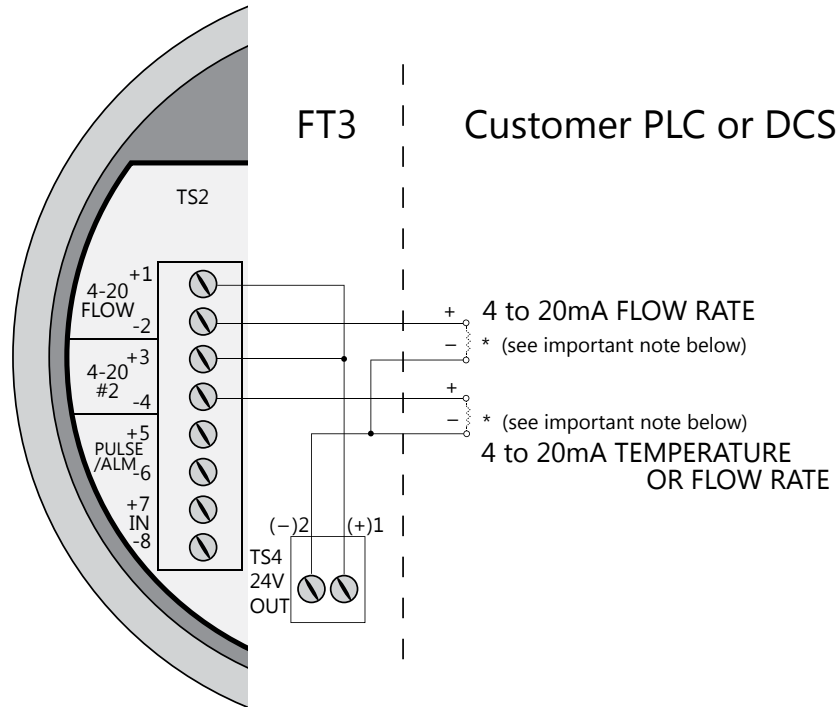

WIRING

NOTE! This wiring option is only available with the isolated 24V output power option.

CAUTION! Do not exceed 42mA total load (ie including 4-20mA outputs).

NOTE! The load resistor on the Fox Thermal Flow Meter 4-20mA signal is typically 250 ohms and is located in or at the customers PLC or DCS. A 250 ohm resistor in the 4-20mA line will result in a 1 to 5VDC signal to the PLC or DCS. Some PLC/DCS equipment has the load resistor built in to the unit; please refer to the PLC/DCS technical manual. **Do not exceed a 600 ohm load on the Fox Thermal Flow Meter 4-20mA signal.**



Wiring

Setting Up the NE-43 Alarms

The FT3 flow meter supports the NAMUR specification NE-43 for alarms on the 4-20 mA output. See p. 31 for the 4-20mA output NAMUR operation.



CAUTION! Configure the FT3 with the following setup when using the 4-20mA output to control equipment in a failsafe application.

4-20mA Failsafe Wiring: NAMUR NE-43

When the 4-20mA output is used to control equipment in failsafe applications:

- Wire the 4-20mA output in series with the Alarm output as shown in Fig. 3.6
- Configure the Pulse/Alarm output to Alarm and select System Alarm as shown in the "Alarm Output" on page 34.

The System Alarm output is designed to allow current to flow during normal operation and interrupts current when power to the meter is lost or in a System Alarm condition.

In the 4-20mA Failsafe Wiring configuration of Fig. 3.6, the 4-20mA signal goes to 0mA if power to the FT3 is lost or a System Alarm occurs.

Fig. 3.6: 4-20mA Failsafe Wiring and Range of 4-20mA Output for NAMUR Alarm

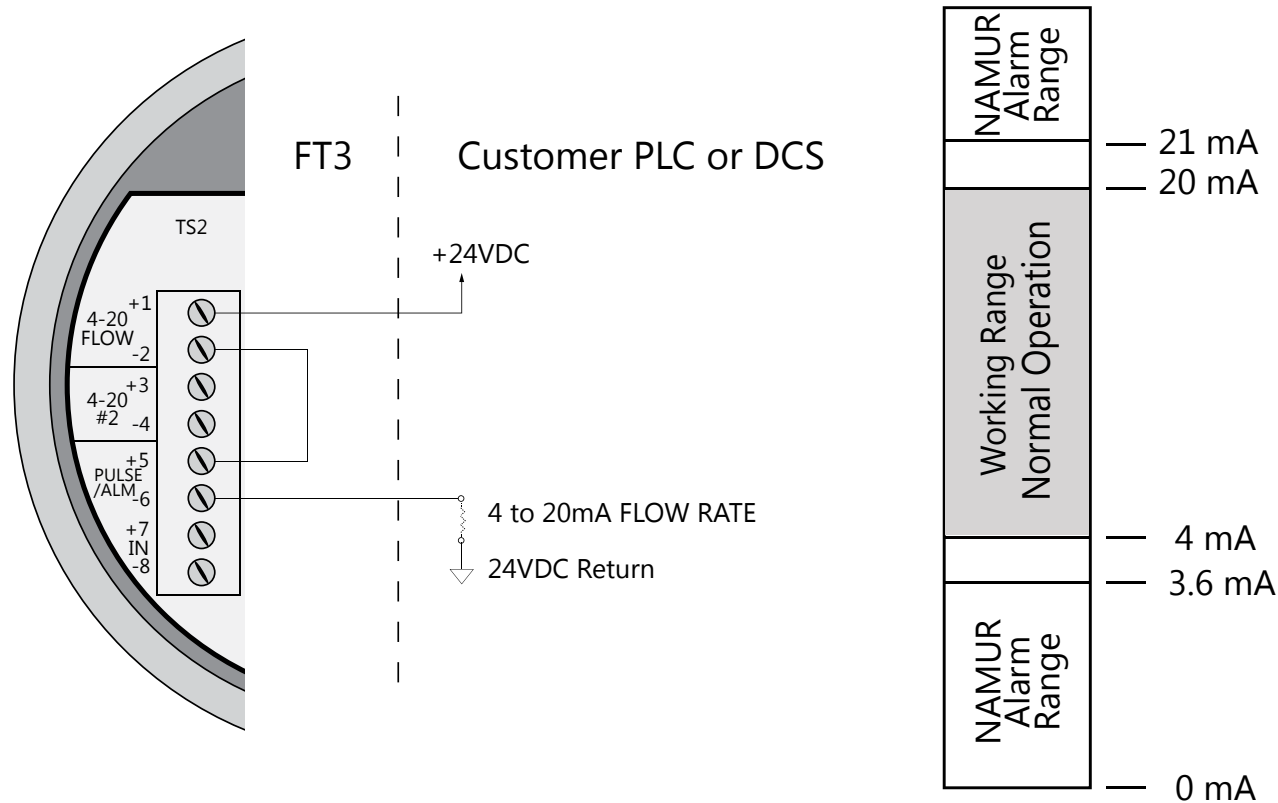



Wiring

Frequency/Alarm Output Wiring

Bring frequency/alarm wiring in through the right-hand conduit hub. Connect to TS2, 5(+) & 6(-). The frequency/alarm output is an open collector circuit capable of sinking a maximum of 20mA of current. Frequency or Alarm selection is programmed using the display. Only one option, frequency or alarm, can be active at a time.

Fig. 3.7: Frequency/Alarm Output Isolated (Recommended)

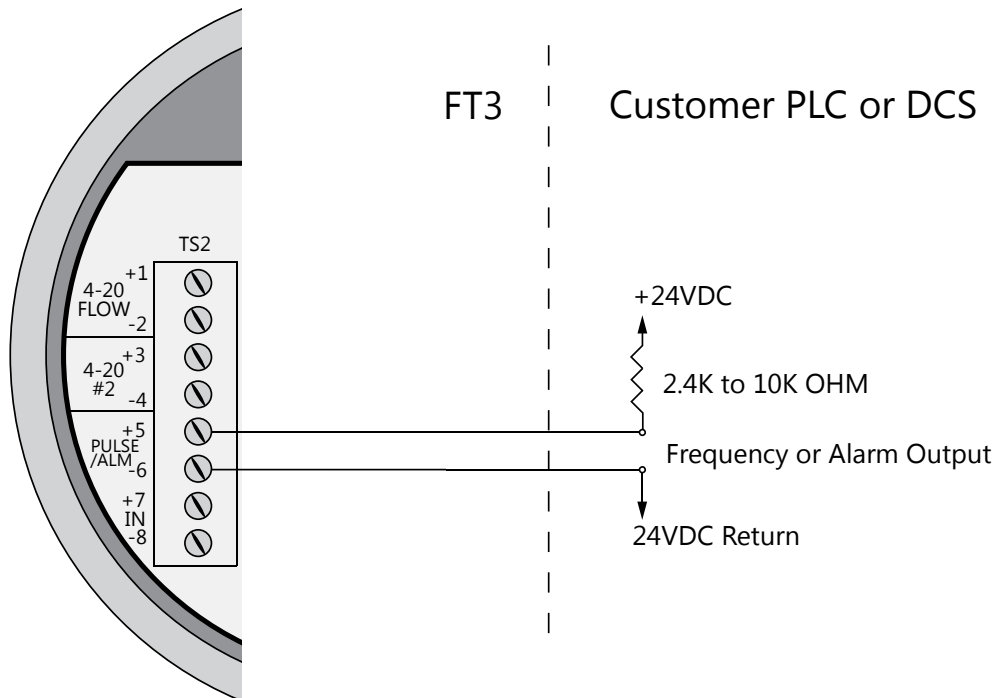

WIRING



NOTE!

The FT3 Frequency/Alarm output is typically used to drive digital circuitry or solid-state relays. The output of a solid state relay may, in turn, operate loads such as electromechanical relays or alarm indicators.



Wiring

Fig. 3.8: Frequency/Alarm Output Local +24V Power Option

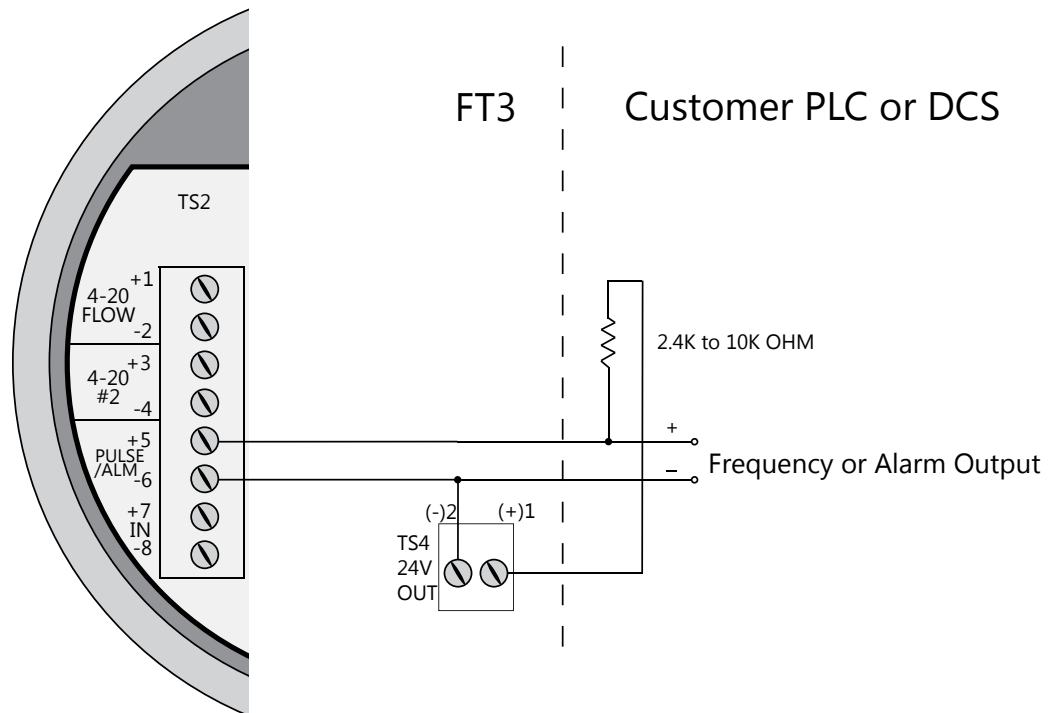

WIRING



CAUTION!

Do not exceed 42 mA total load on the 24V Output TS4 (ie including 4-20mA outputs).

Wiring



Remote Switch Wiring

A remote switch can be used to reset the Totalizer and elapsed time, if enabled in the programming settings. There is no polarity requirement on these connections. Use TS2, 7(+) & 8(-).

When the 2 gas curve option is ordered, the switch can be used to switch between curves.

Fig. 3.9: Remote Switch Wiring

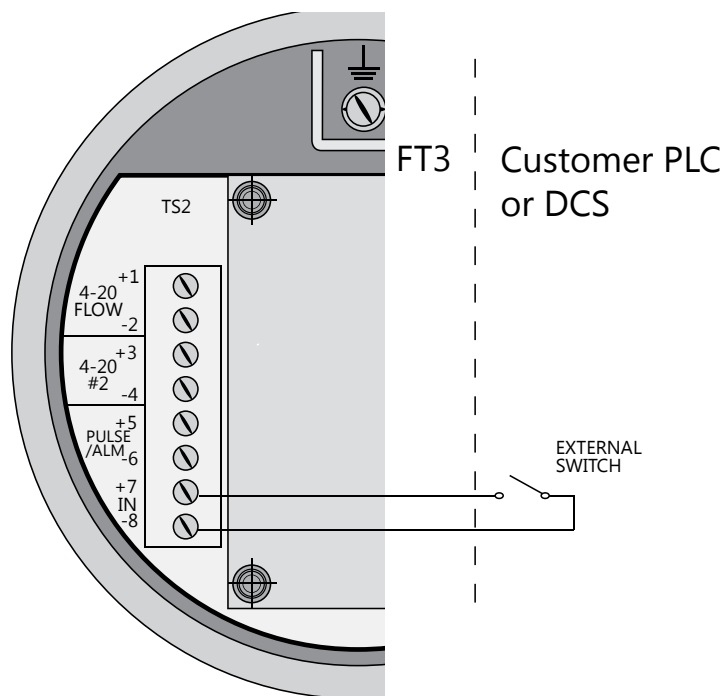

NOTE! If you have purchased RS485 Modbus or HART communications options, please refer to one of the following appropriate Fox Thermal Instructions Manuals:

- Fox Thermal FT3 RS485 Modbus Manual
- Fox Thermal FT3 HART Manual



Wiring

Remote Wiring

Remote wiring will be the same for both insertion and inline type FT3 flow meters.

Fig. 3.10: Remote Wiring

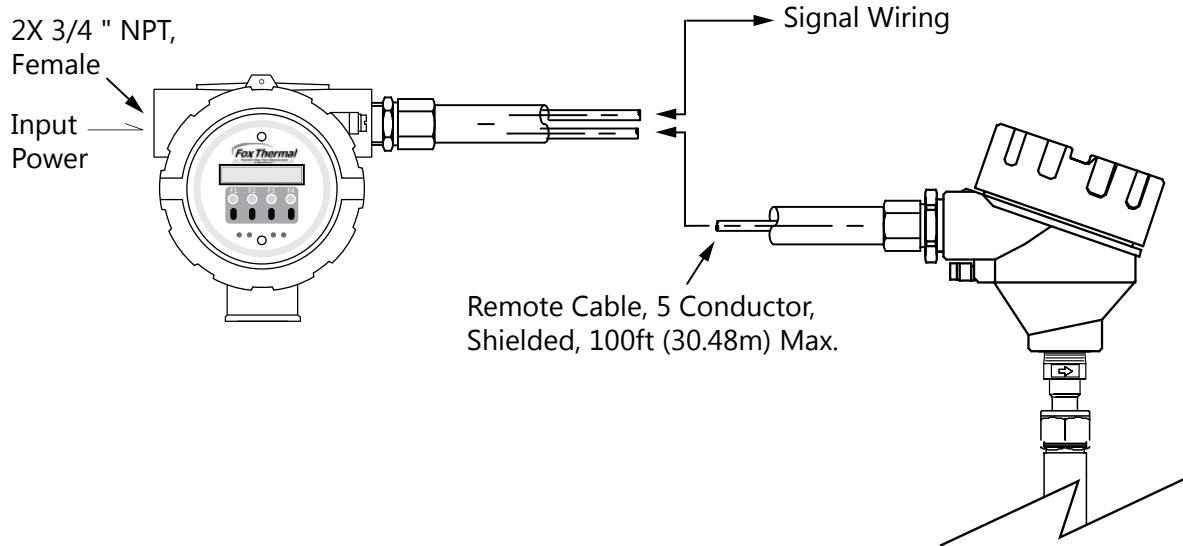

Signal Wiring includes:

4-20mA, pulse, alarm output, contact input, remote switch, USB, and communications options. Power input is 24VDC or optional 100 to 240VAC (+10%/-15%).



NOTE! Remote wiring is only required when the Remote Electronics option is provided.

Five wire shielded cable required. The shielded cable should be run through a separate grounded steel conduit (no other cables or wires in the conduit). If you are using your own cable, make sure that the cable length does not exceed 100 feet and has a wire resistance that does not exceed one ohm (18 AWG recommended).



Do not connect the cable shield at the electronics enclosure end.

Use an extension cable to connect the terminals of the remote probe enclosure to connector TS3 of the electronics enclosure as shown in Figure 3.10 and Table 3.1 (p. 25).



Wiring

Fig. 3.11: Remote Sensor Wiring

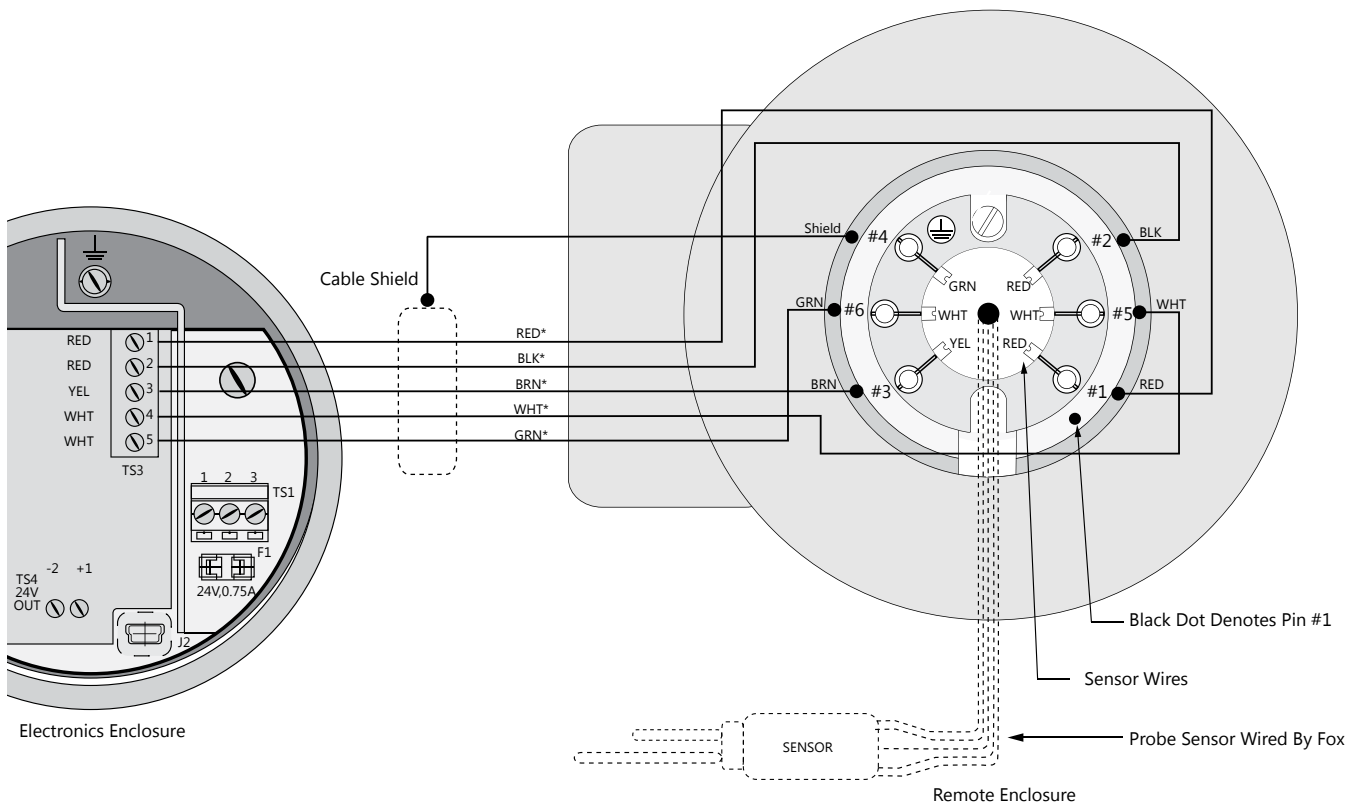

WIRING

*Wire colors listed here represent the wire colors of cables supplied by Fox Thermal. Colors may vary if customer is supplying their own cable.

Table 3.1: Remote Sensor Cable Wiring

Electronics Enclosure Terminal Numbers	Extension Cable Wire Color	Remote Enclosure Terminal Numbers	Sensor Wire Color
1	Red	1	Red
2	Black	2	Red
3	Brown	3	Yellow
No Connection	Shield	4	Green
4	White	5	White
5	Green	6	White

Operation

Start Up Sequence

The program automatically enters the Run/Measure mode after power up. If the Local display is installed, the screen will show the software versions for the FT3 and the display module during power up. Programming of the flow meter can also be accomplished using a Windows-based PC program called FT3View™.

USB Interface

The USB interface is a standard feature which allows communication to a PC in order to monitor readings and configure settings. FT3View™, is a free application program from Fox Thermal that connects to the USB interface and allows data monitoring, configuration setting, data logging to Excel, and an option to save and recall FT3 configuration data. A serial communication manual is available for users who want to create their own PC application.

FT3 Optional Display Panel & Configuration Panel

The FT3 display is a 2 line x 16 character display with 4 mechanical and 4 IR (infrared) buttons. The IR and mechanical buttons perform the same function but the IR buttons can be used without opening the cover. The IR buttons can be calibrated (p. 53) for better operation in the field or disabled (p. 52) when the meter is used in snow or ice in order to avoid false key detection.

Fig. 4.1: FT3 Optional Display and Configuration Panel

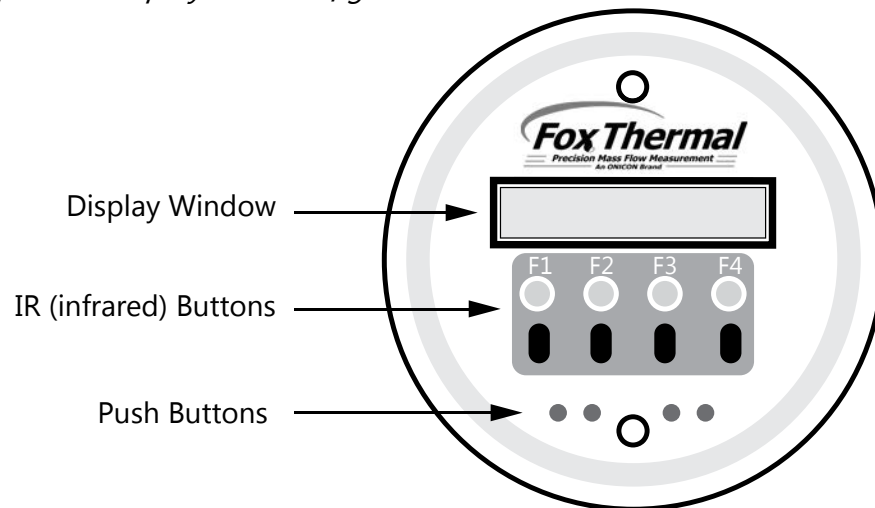

Measurement Mode

In the measurement mode, there are four different display screens (display 1, 2, 3 and a prompt screen to enter the programming mode), two display screens are user programmable (refer to Display Setup p. 36). Scrolling through the display is accomplished by pressing the F1 or F2 key to view the next or previous screen. Pressing the F1 and F2 keys at the same time enters the Engineering Menu screens (display 10 through 26). Keys F1 and F2 are used to scroll through the different screens and key F4 in order to exit to Display #1. Pressing the F3 and F4 keys at the same time brings up the Reset Total screen (see p. 45) prompt.

Operation

Fig. 4.2: FT3 Display Screen Navigation

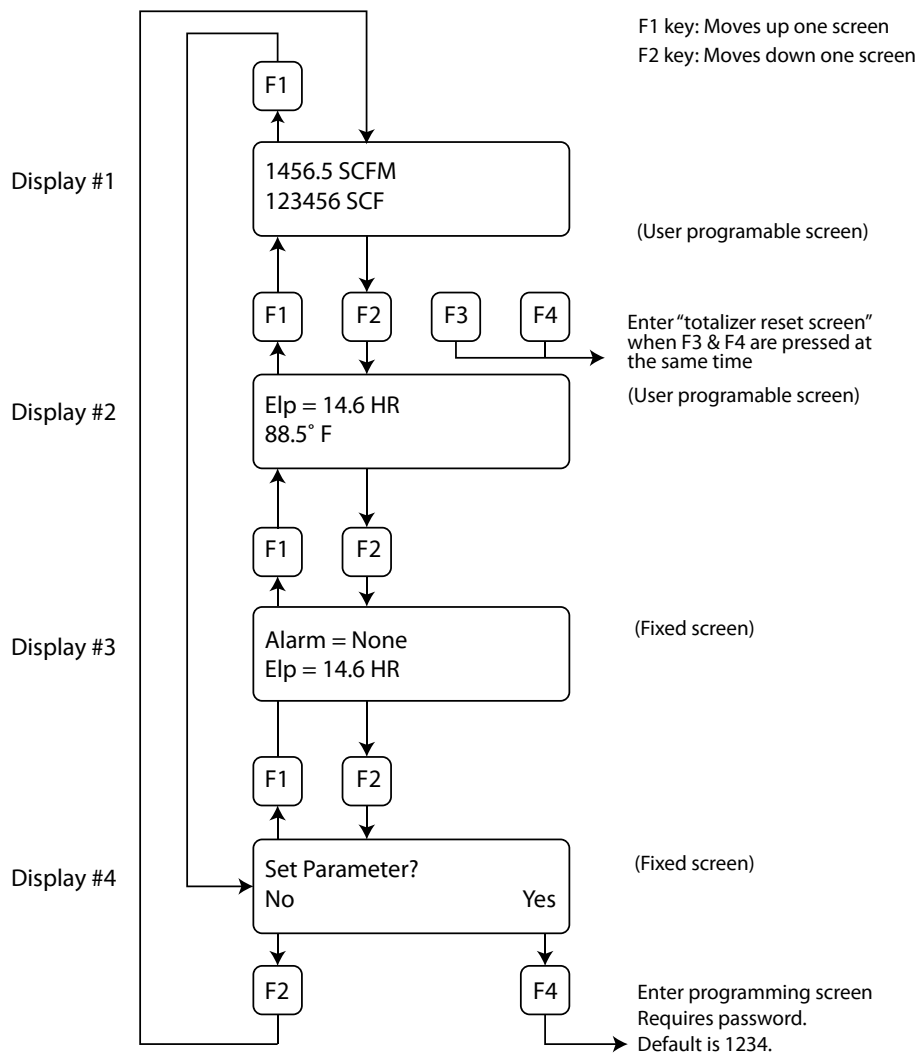

Operation

FT3 Engineering Displays

Pressing the F1 & F2 keys at the same time in the normal mode, brings up the engineering displays. These displays show internal parameters of the FT3 which are used by Fox Thermal service technicians.

Press F4 to exit. Use the F1 & F2 keys to navigate.

Fig. 4.3: FT3 Engineering Displays

Enter: Press F1 & F2 at the same time
Press F4 to return to normal mode

Flow in selected unit	3124.6 SCFM	Display 10
Sensor voltage in volts	csv=0.3432 Volt	
Sensor average volts	CsvAv=366809	Display 11
Velocity in selected unit	Vel=112345.7 FT/M	
Sensor filtered average in volts	FloFlt=3666805.3	Display 12
Velocity in Meter/Hour	Vel=2356.45 M/H	
TSI average count	TsiAvr=512.5 cnt	Display 13
TSV average count	TsvAvr=323.7 cnt	
TSI in volts	Tsi= 2.1345 Volt	Display 14
TSV in volts	Tsv=0.9856 Volt	
TSI current in Amp	Tsi = 0.0435 Amp	Display 15
TSI resistance in Ohm	Tsi = 221.5 Ohm	
RTD9 count	RTD9= 345.5 cnt	Display 16
Gas Temperature in C	Gas Temp=123.7 °C	
CH1 4-20ma current loop count	CH1_420=2167 cnt	Display 17
CH2 4-20 ma current loop count	CH2_420=1234 cnt	
Frequency output count	Feq=1234.5 cnt	Display 18
Alarm codes	Alarm=33,35	
High flow limit alarm	FloHi= 1234 SCFM	Display 19
Low flow limit alarm	FloLo=0 SCFM	
High temperature limit alarm	TmpHi=300 °C	Display 20
Low temperature limit alarm	TmpLo=10 °C	
Elapsed time in hour	Elp=12.5 HR	Display 21
Status in hexadecimal	Stat(hex)=2800	
FT3 main board firmware revision	FT3 V3.02d	Display 22
FT3 display board firmware revision	Display V2.03b	
Power cycle count	Pwr_Cycl=24	Display 23
Error with totalizer count	Err_tot=0	
TSI resistance in ohm	Tsi=221.5 Ohm	Display 24
RTD9 resistance in ohm	RTD9=10.3 Ohm	
CAL-V™ Value	CAL-V=23.51	Display 25
CAL-V™ last verify value	CAL-V Chk=0.2%	
Bridge shutdown detection count	BrShtDnCnt=0 cnt	Display 26
Zero CAL-CHECK® Pipe Ref	ZRO_Pref=xx.xxxx	Display 27
Zero CAL-CHECK® % difference	ZRO_diff=x.xx%	
Zero CAL-CHECK® Bottle Ref	ZRO_Bref=xx.xxxx	Display 28
Zero CAL-CHECK® % difference	ZRO_diff=x.xx%	

F1 Key

F2 Key

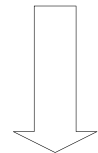
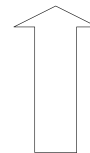

F3 & F4 pressed at the same time will initiate a "Total" reset

Operation

Data Entry using the local display module

There are 2 basic types of menu entries: one for changing value or string and one for selecting from a selection list.

To Change a Value or String :

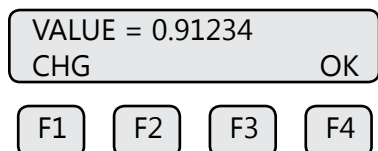

Press **CHG (F1)** key to change the value, **OK (F4)** to accept the value.

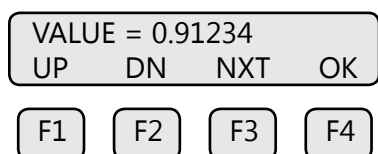

Press the **UP (F1)** or **DN (F2)** key to select a new digit or character, the cursor points to the selected digit. Press **NXT (F3)** to select the next digit and **OK (F4)** to accept the entry.



NOTE! If the **UP (F1)** or **DN (F2)** key is held down for more than 1 second, the program will progressively select new digits at increasing speed as time increases.

To Select from a List:

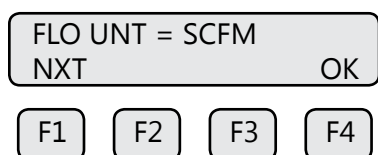

Press **NXT (F1)** key repeatedly until the correct selection is made and **OK (F4)** key to accept the entry.

Entering the Programming Mode

To enter the programming mode, press the F1 or F2 key repeatedly in the normal running mode until the following screen is shown:

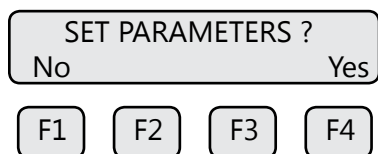

Press **YES (F4)** and the following screen will prompt the user to enter the password if it is active:

Operation

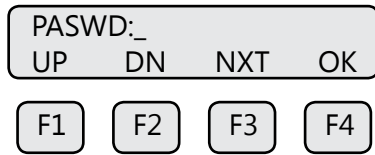

Enter the correct password, then follow the instructions for changing a value as specified above. The default Level 1 password is "1234".

If the wrong password is entered, the message "Wrong Password" will be displayed for a few seconds and then returns to the programming entry screen.

If the password is accepted, the base programming screen will be shown:

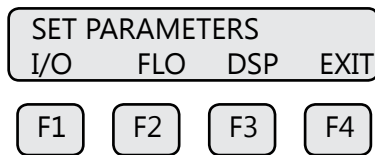

This is the base screen for the programming mode.

Press **EXIT (F4)** repeatedly until "Normal Mode" is seen briefly to exit the programming mode.

Analog 4-20mA Output

The following menu allows the scaling of the analog 4-20mA outputs.

From the base screen, press **I/O (F1)** and then in the next screen press **420 (F3)**.

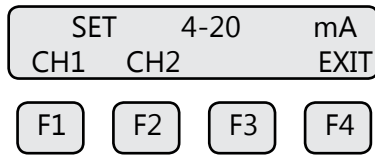
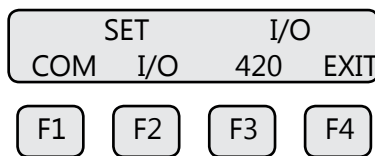

Select **CH1 (F1)** to program channel 1.

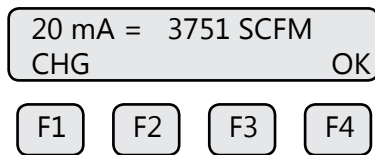

Enter the value for the 20mA and press **OK (F4)** key to accept the setting.

Operation



NOTE! When the flow rate exceeds the programmed value for the 20mA set point, the analog output will stay at 20mA and an alarm code will be generated.

Then the following screen will display:

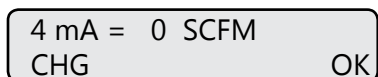

Enter the value for the 4mA and press **OK (F4)**.

NOTE! 4mA is normally set to 0.

The following menu item allows the user to select an alarm level on the 4-20mA output when a serious issue is detected that is preventing the calculation of a correct flow value.

The options are:

- Force the 4-20mA signal to 3.6mA
- Force the 4-20mA signal to 21mA
- Do not force 4-20mA signal (not used)



CAUTION! When using the 4-20mA output to control equipment in a failsafe application, use the wiring configuration on p. 20 and set the Pulse/Alarm Output to System alarm as shown in "Alarm Output" on page 34.

After setting the 4mA output value, choose the mA fault value:

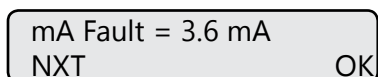

The following events will set the output to 3.6mA or 21mA if the alarm level is selected:

- Sensor resistance above high limit
- Bridge Shutdown

When the 4-20mA output is wired through the System Alarm, the following cause the output to go to 0 mA:

- Power to the Microprocessor is lost
- Sensor or electronics failure

Fig. 4.4: Range of 4-20mA Output and NAMUR Alarm

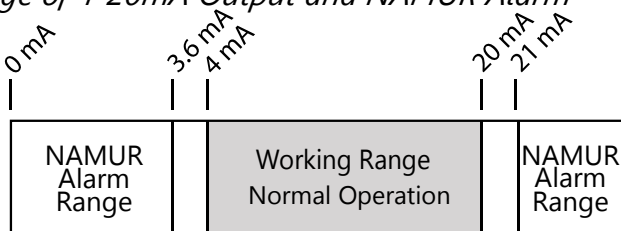

Operation

Press **(F4)** repeatedly until "Normal Mode" is seen briefly to exit the programming mode.

Select **CH2 (F2)** to program channel 2.

Channel 2 is programmable for flow (CH2=Flow) or temperature (CH2=Temp).

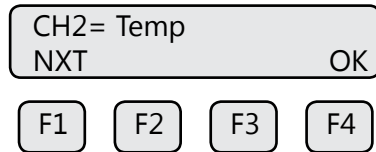

Press **NXT (F1)** to select Flow or Temperature and then press **OK (F4)**.

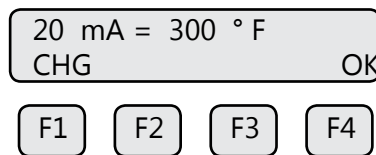

Enter the value for the 20mA and press **OK (F4)** key to accept setting.

Then the following screen will show:

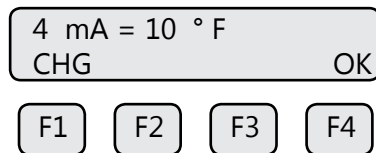

Enter the value for the 4mA and press **OK (F4)**.

Press **EXIT (F4)** repeatedly until "Normal Mode" is seen briefly to exit the programming mode.

Frequency Output

From the main menu, press **I/O (F1)**, **I/O (F2)** and then **OUT (F2)**

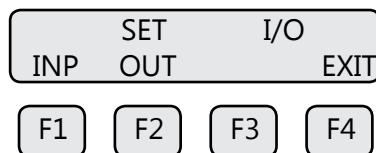

Press **OUT (F2)** to select output and the following screen may show:

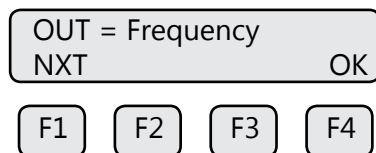

Press **NEXT (F1)** to cycle through output options until you have the selection for "OUT=Frequency" and press **OK (F4)**.

Operation

The frequency output can be configured in one of three ways:

(1) specifying a maximum frequency to a defined maximum value of flow rate, (2) specifying how many flow units total per pulse, U/P (i.e., 0.1 SCF per pulse) or (3) specifying how many pulses per unit, P/U (i.e., 10 pulses per SCF). All of these approaches are equivalent.

FREQUENCY OUTPUT
P/U U/P FEQ EXIT

F1 F2 F3 F4

Use **P/U (F1)** to enter pulse per unit, **U/P (F2)** for Unit per pulse or **FEQ (F3)** to enter the flow and maximum frequency to scale the frequency output.



NOTE! When data is entered with any of the three described methods, the other values will be re-calculated according to the settings.

Entering data in Pulse per Unit:

Press **P/U (F1)** and the following screen will show:

PLS/UNT = 1.2
CHG OK

F1 F2 F3 F4

Press **CHG (F1)** to change the setting and then **OK (F4)** to accept entry. The value entered is in pulse per selected flow unit total (i.e., 10 pulses per SCF)

Entering data in Unit per Pulse:

Press **U/P (F2)** and the following screen will show:

UNT/PLS = 0.01
CHG OK

F1 F2 F3 F4

Press **CHG (F1)** to change the setting and then **OK (F4)** to accept entry. The value entered is in unit per pulse (i.e. 0.01 flow unit total per pulse)

Entering data with flow and maximum frequency:

Press **FEQ (F3)** and the following screen will show:

MaxFreq=98.5 Hz
CHG OK

F1 F2 F3 F4

Enter the maximum pulse rate (frequency) and press **OK (F4)**.

Operation



CAUTION! Maximum pulse rate (frequency) cannot exceed 100 Hz.

The next screen will show:

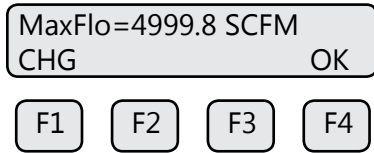

NOTE! If the flow rate exceeds the maximum pulse rate (frequency), the output will stay at 100 Hz and the FT3 will issue an alarm code.

Alarm Output

To program the Alarm output, press **I/O (F1)** key from the "SET PARAMETERS" menu screen, then select **I/O (F2)** and the screen will show:

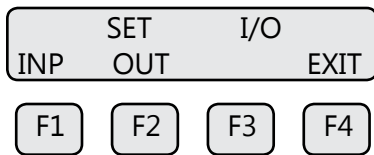

Then press **OUT (F2)** and the screen may show:

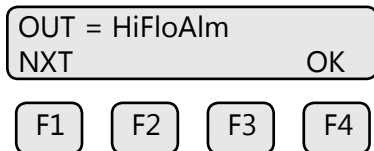

Then press **NXT (F1)** to select the correct alarm and press **OK (F4)**.
 Selections are:

- HiFloAlm = High Flow Alarm
- LoFloAlm = Low Flow Alarm
- HiTempAlm = High Temperature Alarm
- LoTempAlm = Low Temperature Alarm
- System Alm = System Alarm
- Not used
- Frequency

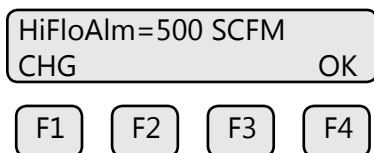

Enter the value for the limit by pressing **CHG (F1)** and then **OK (F4)**.

Operation



NOTE! There is only one output to operate as a frequency output or an alarm output. Both cannot operate at the same time.

For Contact Input Settings:

From the main menu, press **I/O (F1)**, then **I/O (F2)**, then **INP (F1)** to select input. The following will display:

INP = Not Used		
NXT		OK

F1 F2 F3 F4

Press **NXT (F1)** repeatedly until the correct selection is shown and then press **OK (F4)** to accept the setting.

Selections are:

- Not used
- Tot Reset = Reset the totalizer
- Switch Crv = Switch between calibration curve 1 and curve 2 (only if 2 gas curve ordered)

Press **EXIT (F4)** repeatedly until you exit programming mode.

Serial Communication Settings

To program the Serial communication settings, press **I/O (F1)** key from the base menu.

SET I/O			
COM	I/O	420	EXIT

F1 F2 F3 F4

NOTE!

Power cycle is required for the new settings to take effect.

Press **COM (F1)** to select Serial communication:

Comm=Modbus		
NXT		OK

F1 F2 F3 F4

Options for serial communication are:

- Not Used
- HART
- Modbus



NOTE! Any selection other than "Not Used" requires the communication option for the selected communication type. If enabling a communication option, see the associated Fox Thermal Communication Manual for specific programming information: FT3 Modbus Manual or FT3 HART Manual.

Operation

Display Setup

There are four display screens that you can cycle through in normal operating mode (see Figure 4.2 on p. 27). Two of the four display screens are fixed and cannot be changed (displays #3 & 4). The other two screens are programmable to show the information that you prefer and are discussed in this section.

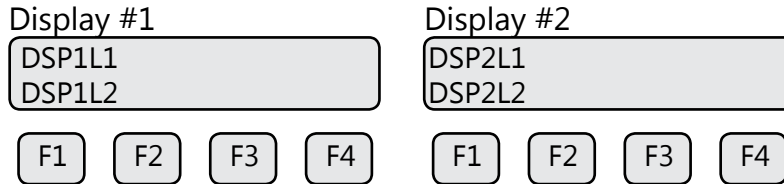

Selections are:

- | | |
|--------|-------------------|
| DSP1L1 | Display 1, Line 1 |
| DSP1L2 | Display 1, Line 2 |
| DSP2L1 | Display 2, Line 1 |
| DSP2L2 | Display 2, Line 2 |

To Program Display Screens #1 & 2:

From the base programming menu press **DSP (F3)** to select the display menu:

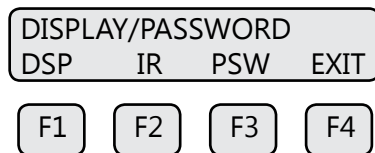
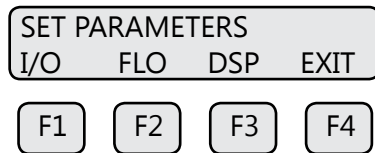

Press **DSP (F1)** key. The display will show:

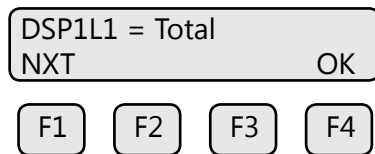

These are the selections for the display #1 line #1.

Selections are:

- | | |
|----------|--------------|
| Flo rate | Flow rate |
| Total | Total mass |
| Elps | Elapsed time |
| Temp | Temperature |
| Alarm | Error codes |

Operation

When the selection is correct, press **OK (F4)** to accept. The display will then go through the same process for all 4 lines of the 2 programmable displays (DSP1L1, DSP1L2, DSP2L1 and DSP2L2).

After the last line of display 2 is accepted, the display will show the following menu:

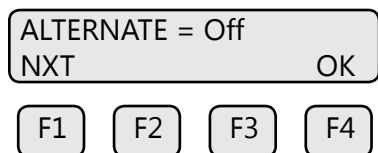

This menu allows you to alternate between menu display 1 and 2 every few seconds. Selections are: On or Off

Press **OK (F4)** to accept selection.

Press **EXIT (F4)** repeatedly until "Normal Mode" is seen briefly to exit the programming mode.

Password

There are two user level passwords, only Level 1 is programmable and gives access to all the normal settings. The second password is used to allow access to calibration factors and should normally never be changed unless advised by the Fox Thermal service department, or to set a new password in the event that the user forgets the Level 1 password.

Default Level 1 password is "1234", and Level 2 password is "9111".

The Level 1 programmable password can be disabled by setting it to "0".

From the base programming menu press **DSP (F3)** to select the display menu:

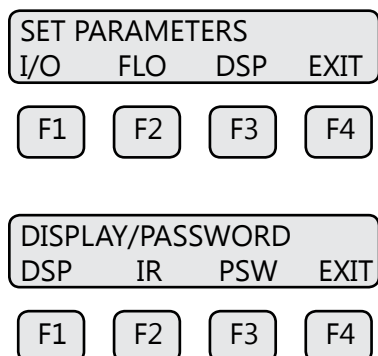

Operation

To Program the Password:

Press **PSW (F2)** key to select password.

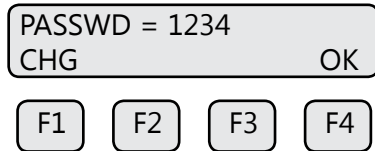

This screen displays the current Level 1 password.

Press **CHG (F1)** key to change the password and enter new value (see p. 29 for further details).

Press **OK (F4)** to accept new data and exit programming by pressing **EXIT (F4)** key repeatedly until out of the programming mode.



NOTE! Password can be number or letter characters up to 4 digits.

Units Settings

This menu is used to set the units for mass flow, temperature, pressure reference and the settings of reference temperature, reference pressure and density of gas when using Lbs/time or Kg/time.

These values will be set at Fox Thermal, using the Application Data Sheet values. If the customer changes the application, these values can be changed to match the new application. Check with Fox Thermal customer service before changing the application gas.

The unit setting is accessed from the base programming menu by pressing **FLO (F2)**:

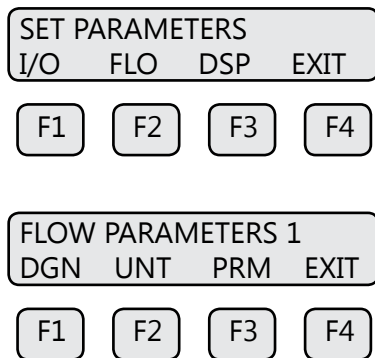

Press **UNT (F2)** for Unit selection:

Operation

FLO = SCFM
NXT OK

F1 F2 F3 F4

Press **NXT (F1)** to change selection and **OK (F4)** to accept.

Selections for Flow unit are:

SCFM	LBS/H	SFPM	MT/H
SCFH	LBS/M	MMSCFD (MMCFD)	NM3/D
NM3/H	LBS/S	LBS/D	MMSCFM (MMCFM)
NM3/M	NLPH	SLPM	SCFD
KG/H	NLPM	NLPS	MCFD (MSCFD)
KG/M	SMPS	MSCFD (MCFD)	SM3/M
KG/S	NMPS	SM3/H	SM3/D

NOTE! The totalizer must be reset immediately after changing the flow units setting.



NOTE! The totalizer (total flow measured) will roll over when reaching a certain value. The maximum value is dependent on the flow units selected. For maximum total rollover values, please see "" on page 45.



WARNING! The FT3 re-calculates area, 4 and 20mA values, maximum flow for the frequency output and zero flow cutoff when changing flow units except for velocity units. When going to or from velocity units, the FT3 will not recalculate these values and these values must be re-entered manually.

Temperature Unit

After pressing **OK (F4)** to accept the Flow unit the display will prompt for the temperature unit setting:

TMP UNT= Deg F
NXT OK

F1 F2 F3 F4

Press **NXT (F1)** to change selection and **OK (F4)** to accept.

Selections for Temperature unit are:

- Deg C
- Deg F

Operation

Reference Temperature

After pressing **OK (F4)** to accept the temperature unit setting, the display will prompt for temperature reference in selected unit.

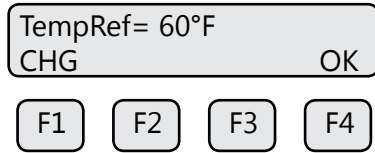

Press **CHG (F1)** to change the reference and **OK (F4)** to accept.

Pressure Unit

After pressing **OK (F4)** to accept the reference temperature, the display will prompt for the pressure unit selection:

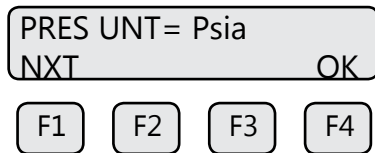

Press **NXT (F1)** to select next entry and **OK (F4)** to accept.

Selections are:

- mmHG Millimeters of mercury
- Psia Pounds per square inch atmosphere
- bara Bar atmosphere

Reference Pressure

After the pressure unit selection is made, the display will show a menu to enter the pressure reference:

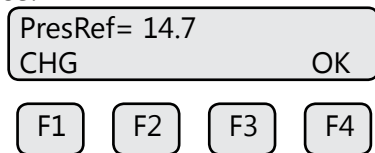

Gas Density

Press **CHG (F1)** to change it and **OK (F4)** to accept. After the pressure reference is accepted, the display will prompt for the gas density if LBS or KG was selected for flow unit:

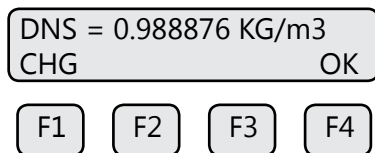

Press **CHG (F1)** to change and **OK (F4)** to accept.

Operation



NOTE! The density entry is only used when KG/time or LBS/time is selected for flow rate units.

Density conditions are referenced to 0 C° at 760 mmHg.

Flow Parameters

This is the menu used to set various flow parameter values. They are: Flow cutoff, pipe area, filter, high and low alarm for flow and temperature.

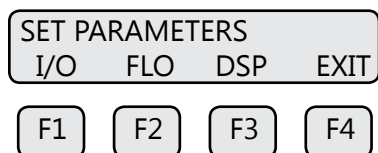

The menu is accessed from the base programming menu by pressing **FLO (F2)**:

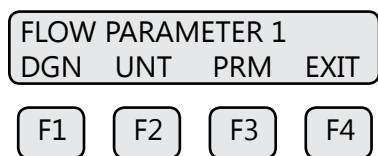

Then press **PRM (F3)**. The screen will show:

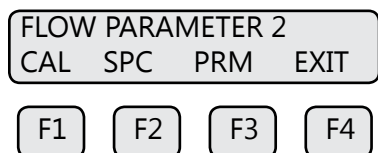

NOTE! The CAL and SPC function key will only appear and be accessible from a Level 2 password.

Flow Cutoff

Then press **PRM (F3)** for flow cutoff:

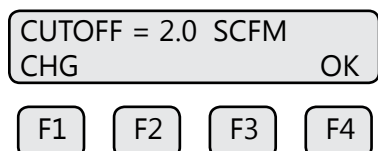

When the flow rate falls below the zero flow cutoff, the flow meter will display a flow value of zero. Enter the value for the percent low flow cutoff and then press **OK (F4)**.

Operation

Pipe Area

Enter the pipe area in square meters or square feet and then press **OK (F4)**. Use square meter for metric flow unit selection and square feet for English flow unit selection.



Filter Value

The filter value is next.

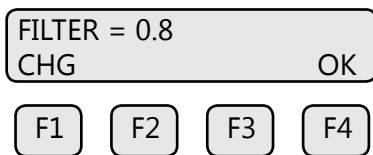

The filter value is also referred to as a dampening factor and is used to quiet the readings. The filter value is an exponential filter that dampens the noise and is used as follows:

$$\text{Flow Value} = (\text{FA} * \text{new value}) + (\text{FB} * \text{average})$$

Where FA = filter value, FA + FB is equal to 1.0.

A lower filter value will increase dampening of the flow rate and smooth the reading. A lower filter value will also slow the meter's response. For example, if we enter a filter of 0.8, the weight ratio for new average is:

$$\text{New average} = (80\% \text{ new sample}) + (20\% \text{ last average})$$

Filter range is 0.01 to 1.0, 0.01 being a high filter value and 1.0 = no filter.

Filter	Response (Sec.) 65% of Target
0.09	0.10
0.8	0.15
0.7	0.20
0.6	0.25
0.5	0.30
0.4	0.35
0.3	0.40
0.2	0.60
0.1	1.00
0.05	2.00
0.03	3.00
0.01	10.3

Enter the filter value and then press **OK (F4)**.

Operation

High Flow Alarm

HiFloAlm = 1234 SCFM
CHG OK

F1 F2 F3 F4

This is the upper flow limit alarm value that can be associated with a Contact output. An alarm code is generated when the flow value exceeds this limit. If no checking is needed, this value should be set to zero.

Press **OK (F4)** to accept the value.

Low Flow Alarm

LoFloAlm = 100 SCFM
CHG OK

F1 F2 F3 F4

This is the lower flow limit alarm value that can be associated with a Contact output. An alarm code is generated when the flow value is below this limit. If no checking is needed, this value should be set to zero.

Press **OK (F4)** to accept the value.

High Temperature Alarm

HiTmpAlm = 230 C
CHG OK

F1 F2 F3 F4

This is the upper temperature limit alarm value that can be associated with a Contact output. An alarm code is generated when the temperature value exceeds this limit. If no checking is needed, this value should be set to zero.

Press **OK (F4)** to accept the value.

Low Temperature Alarm

LoTmpAlm = 50 C
CHG OK

F1 F2 F3 F4

This is the lower temperature limit alarm value that can be associated with a Contact output. An alarm code is generated when the temperature value is below this limit. If no checking is needed, this value should be set to zero.

Press **OK (F4)** to accept the value.



NOTE! If the programming menu was entered with a Level 2 password, then more menus will be shown that deal with factory set parameters that should not be changed.

Operation

Calibration Parameters

This menu allows changing the factory calibrated setting of the flow meter and is accessible with a Level 2 password. Calibration parameter values are set for temperature and pressure at 0 degree C and 760 mmHg. These settings should normally never be changed except by Fox Thermal personnel at the factory.

This menu is entered from the base menu and pressing FLO, PRM and CAL.

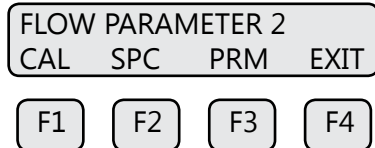

Press **CAL (F1)** then the display will show:

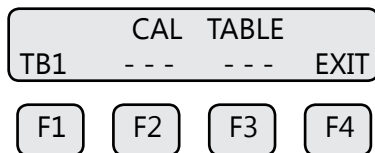

Press **TB1 (F1)** then the display will show:

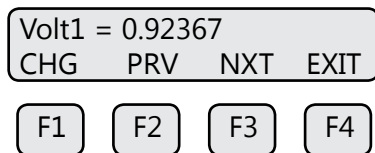

Press **NXT (F3)** then the display will show:

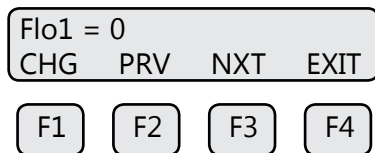

Use the **CHG (F1)** key to change the entry, **PRV (F2)** to move to the previous entry, **NXT (F3)** to move to the next entry and **EXIT (F4)** to return.

Pressing the **NXT (F3)** key will show the data point voltage and then mass velocity and then go to the next data point. The number after Volt (i.e., Volt1) or Flo (i.e., Flo1) indicated the data point number.

The calibration table can hold up to 20 data pair points. Each data point has a voltage and mass velocity associated with it.

Operation

Reset Total and Elapsed Time

The resetting of the totalizer and elapsed time is accomplished by pressing the F3 and F4 keys at the same time in the normal running mode.

RESET TOTAL ?			
NO	YES		
F1	F2	F3	F4

Press **YES (F4)** to reset total and **NO (F1)** to cancel.



NOTE! This feature is not available on non-resettable units.



NOTE! A power failure or resetting the total will cause the Contract Time to change. Data Logger with a Real Time Clock (RTC) option should be used to avoid this.

Totalizer Rollover

The FT3 has an automatic roll-over function. The total flow count of the FT2A will roll over after the following values:

- Most flow units: 99,999,999,999
- MSCFD: 999,999,999
- MMSCFM: 9,999,999
- MMSCFD: 999,999

K Factor and Restore Database

Restoring the original factory settings is accomplished from the "Flow Parameter 2" menu by entering a Level 2 password "9111" and pressing the **SPC** key (**F2**).

K fact = 0 %			
CHG	OK		
F1	F2	F3	F4

Upon pressing **OK (F4)**, an option to restore the database will follow:

RESTORE DATABASE ?			
YES	NO		
F1	F2	F3	F4

Press **YES (F1)** ONLY if you want to restore your database to the initial factory setting that the meter was shipped with. All current user-entered settings will be overwritten.

The green LP1 LED will flash at a faster pace until the recall is performed. The "RESET CRC" screen will follow "RESTORE DATABASE".

Operation

Reset CRC

If the NVRAM CRC check fails (Error Code 36), the programmed settings values will need to be verified and corrected before clearing the error. Call Fox Thermal Customer Service if you need assistance.

RESET CRC?			
YES	NO		
F1	F2	F3	F4

Press **YES (F1)** ONLY if you want to reset the CRC and generate a new CRC value.

Simulation

This menu allows for the simulation of flow rate, temperature and flow input voltage. It should only be used for testing and demonstration purposes.

Make sure to return all of these simulation values to zero, before returning to the normal mode of operation.



NOTE! Simulated values are only enabled when not set to zero.



CAUTION! If the 4-20mA and/or the pulse outputs are connected to controllers, set the controllers to "manual". This will ensure that the simulated signals do not cause false controller action.

The menu is accessible from the main programming menu by pressing **FLO**, and **DGN (F1)**:

FLOW PARAMETER 1			
DGN	UNT	PRM	EXIT
F1	F2	F3	F4

Pressing **DGN (F1)** will show:

DIAGNOSTIC			
SIM	TST	EXIT	
F1	F2	F3	F4

Pressing **SIM (F1)** will show:

FloSim = 0 SCFM			
CHG	OK		
F1	F2	F3	F4

Operation

Enter the value and then press **OK (F4)**.



NOTE! Enter zero to disable this feature.

TmpSim = 0 C
CHG OK

F1 F2 F3 F4

Enter the value and then press **OK (F4)**.



NOTE! Enter zero to disable this feature.

CsvSim = 0 V
CHG OK

F1 F2 F3 F4

Enter the value and then press **OK (F4)**.



NOTE! This value is used to simulate the Current Sense Voltage (CSV) and should be set to zero for normal mode.

ENABLE SIM?
YES NO

F1 F2 F3 F4

Press **YES (F1)** to start the simulation mode, otherwise press **NO (F4)**. Upon pressing either key, the program will return to the FLOW PARAMETER 1 menu.



NOTE! Simulation Mode will be cleared if the power is cycled.

Operation

CAL-V™ - Calibration Validation Test 1

This menu allows the user to confirm the calibration of the FT3 by verifying the functionality of the sensor and sensor signal processing circuitry. During the CAL-V™ calibration validation test, the microprocessor adjusts current to the sensor elements and determines the resulting electrical characteristics. These site characteristics are compared with the data that was collected at the factory during the original meter calibration. Matching data within established tolerances confirms the meter is accurate. This test can be performed under no flow or normal flow conditions. The test takes up to four minutes to complete. At the conclusion of the test, a Pass or Fail message will be displayed. Press F4 at the conclusion of the test to return to normal measuring mode or to terminate the test.

Press **FLO (F2)** from the main menu. The display will show:

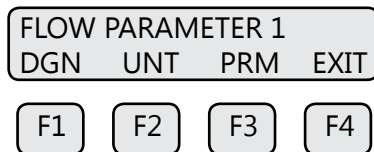

Press **DGN (F1)**. The display will show:

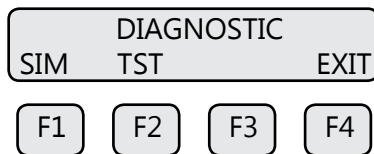

Press **TST (F2)**. The display will show:

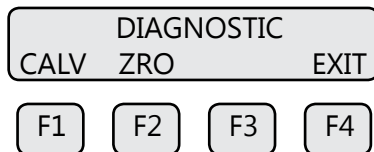

Press **CALV (F1)** to perform the CAL-V™ verification test.



NOTE! The FT3 will stop measuring flow when performing this test. Press **EXIT (F4)** to exit if you do not wish to continue.

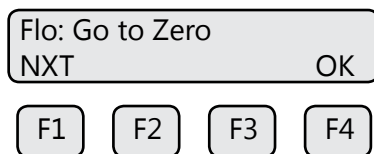

Operation

To select what the flow output will do during a CAL-V™, choose from these options:

- Go To Zero: Flow output will be zero during the test (i.e. 4mA)
- Hold Value: Flow will hold last value during the test

Select the option and press **OK (F4)**.

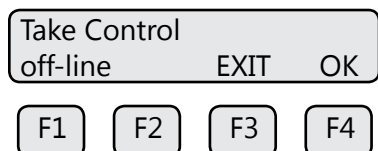

WARNING! If you are using a closed loop control, the system must be taken off-line during the test.

Press **OK (F4)** to start CAL-V™. CAL-V™ test screen:

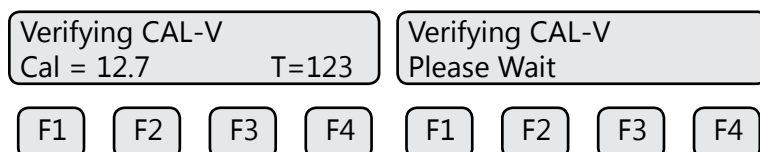

This test will take up to 4 minutes (less time if there is flow) and will show the Cal value changing as the power to the sensor is adjusted. The T=xxx is a count down timer indicating how much time is left to finish the test. A "Please Wait" message will be flashing on and off on line 2 during this test.

Upon test completion, the final CAL-V™ value will be displayed along with a Pass/Fail message.

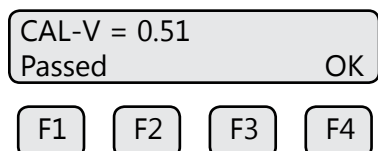

CAUTION!

- The CAL-V™ test is valid for checking the calibration accuracy of flow meters installed in the applications for which it was calibrated including the gas/gas mixture, calibration range and pipe size shown on the calibration certificate.
- For applications with temperature exceeding 250°F (121°C), CAL-V™ test results may vary.
- Periodic inspection for damage and cleaning of the sensor elements is required.

Operation

Zero CAL-CHECK® - Calibration Validation Test 2

The Zero CAL-CHECK® test is a companion test to CAL-V™. Unlike CAL-V™, which may be performed in the pipe and at process conditions, Zero CAL-CHECK® must be performed at zero flow to ensure a valid test result. This test is used to confirm that the flow meter still retains its original NIST-traceable calibration at zero flow and that the sensor is free of film or residue that may affect readings. The test takes less than 5 minutes to complete. At the conclusion of the test, a Pass or Fail message will be displayed. Press F4 at the conclusion of the test to return to normal measuring mode or to terminate the test. See Calibration Validation User's Guide for more details.

Press **FLO (F2)** from the main menu. The display will show:

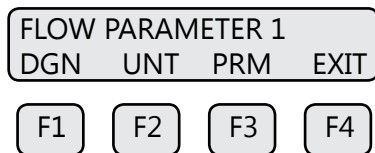

Press **DGN (F1)**. The display will show:

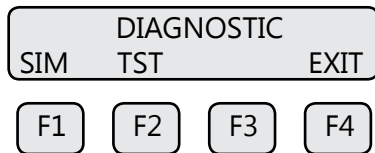

Press **TST (F2)**. The display will show:

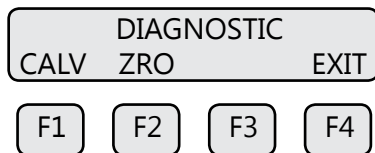

Press **ZRO (F2)** to enter the Zero CAL-CHECK® menu.

If performing the test in the pipe, a "no flow" condition must be met. If performing out of the pipe, the meter must be removed and the sensor protected by the PVC sensor cover originally shipped with the meter from the factory.



NOTE!

- The field baseline for a Zero CAL-CHECK® test performed in the pipe ("ZERO PIPE TEST") must be set before performing the test.
- See the Fox Thermal Calibration Validation User's Guide for details on performing all diagnostic tests.
- Please use the PVC sensor cover that was shipped with your meter perform Zero CAL-CHECK® tests out of pipe ("ZERO BTL TEST").

Operation

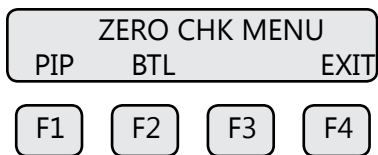

Press **PIP (F1)** to choose to perform the test in the pipe. Press **BTL (F2)** to choose to perform the test out of the pipe.

The display will show:

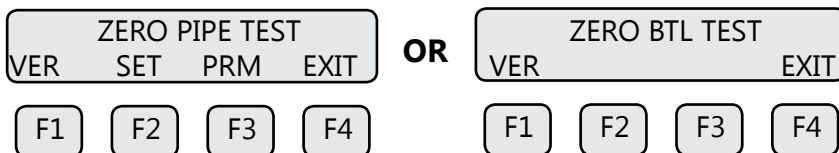

Press **VER (F1)** key to verify the Zero CAL-CHECK®.



Press **YES (F1)** key to verify the Zero CAL-CHECK®.

 **WARNING!** If you are doing a "Pipe" test, you must verify that there is a no flow condition before proceeding. If you are performing the test in a bottle, be sure to isolate the sensor in a bottle - any air movement (even from a fan) can result in a false "fail" result.

Once process is stable, press **YES (F4)** key to begin the Zero CAL-CHECK®.

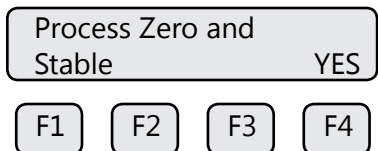

NOTE!

- Refer to the Fox Thermal FT3 Calibration Validation User's Guide for information on setting the field baseline for Zero CAL-CHECK® tests if you plan to perform these tests in the pipe.
- Please save the PVC sensor cover that was shipped with your meter. It will be needed to perform Zero CAL-CHECK® tests out of pipe.

Operation

Verifying ZRO Diff = xx.xx T=xx	Verifying ZRO Sd = x.xe-xx T=xx
F1 F2 F3 F4	F1 F2 F3 F4

This test will take less than 5 minutes. The T=xx is a count down timer indicating how much time is left to finish the test.

Diff=x.xxx % Passed OK
F1 F2 F3 F4

Upon test completion, the final percentage value will be displayed along with a Pass/Fail message.

Enabling/Disabling the Infrared Keypad (IR Buttons)

The IR buttons may be disabled from the menu to avoid being triggered by frost or snow on the window. This menu is accessed by pressing **DSP (F3)** from the main menu then **IR (F2)**:

IR KEY= Enabled NXT OK
F1 F2 F3 F4

Press **NXT (F1)** key to enable or disable the IR buttons.



NOTE! After selecting "Disable" and pressing **OK (F4)**, the IR buttons will no longer operate. It will be necessary from now on to open the cover and operate the configuration panel using the mechanical push buttons. To return to the normal display mode, use mechanical buttons or wait for the programming mode timeout.

Operation

Calibrating the Infrared Keypad (IR Buttons)

The IR buttons are calibrated in the factory before shipment, but conditions in the field may alter the way the buttons read. To allow the IR buttons to perform better, it may be necessary to calibrate the keys in the field.

Use your finger to activate the IR buttons using this process:



NOTE! Your finger must activate each button approximately 0.1" to .5" from the surface of the glass.

Press the **(F1)** button until the display shows 'SET PARAMETER?' Then use **YES (F4)**.

Use buttons **(F1)** **(F2)** and **(F3)** to enter "1111" (up/down and next).

Use buttons **(F1)** **(F2)** and **(F3)** to enter "0000" then press **OK (F4)**.

Turn OFF power to the FT3.

Turn ON power to the FT3 while placing your finger on the **(F1)** IR key.

Operation

Fig. 4.5: FT3 Menu Tree - Main Menu

OPERATION

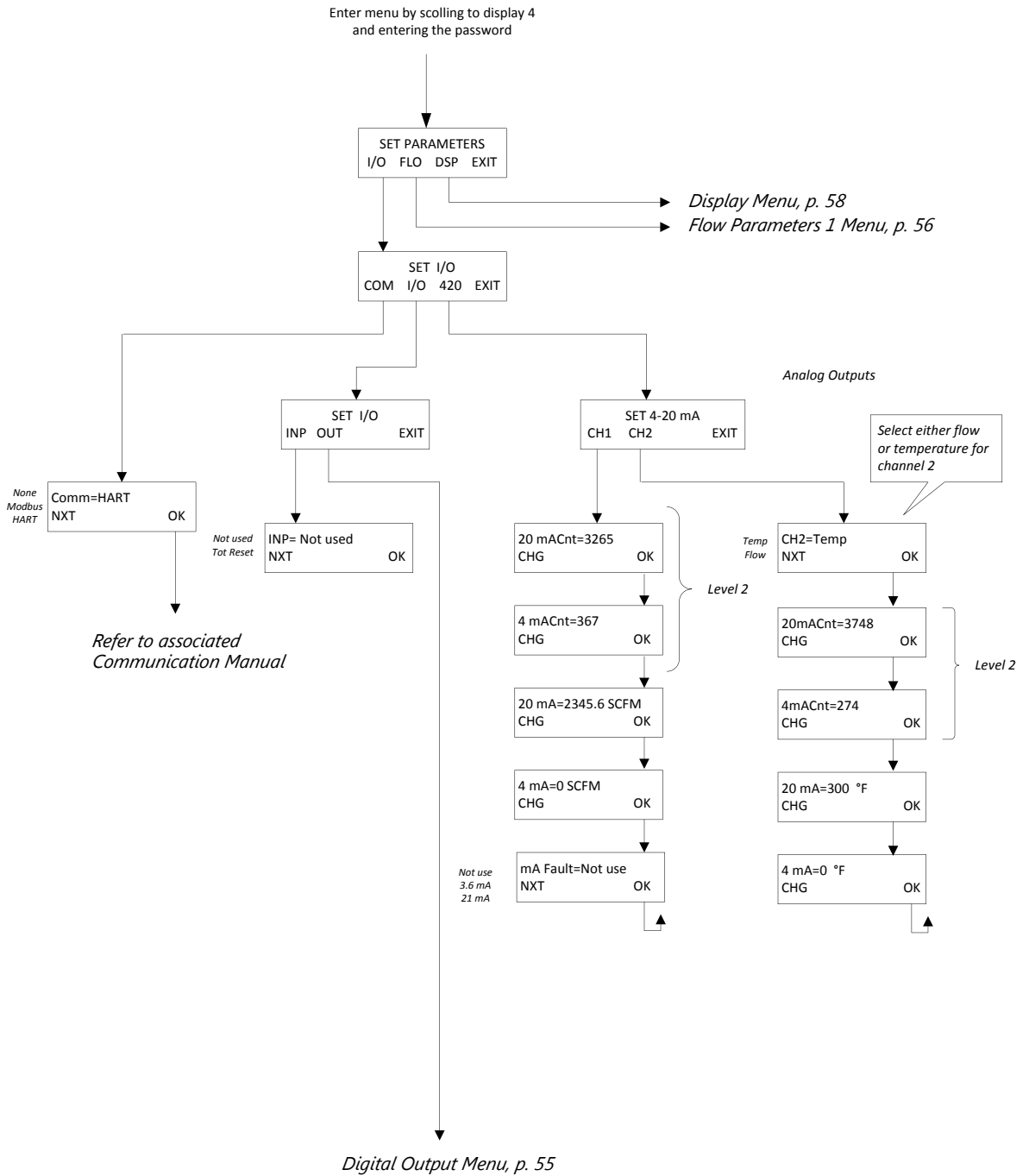

Operation

Fig. 4.6: FT3 Menu Tree - Digital Output

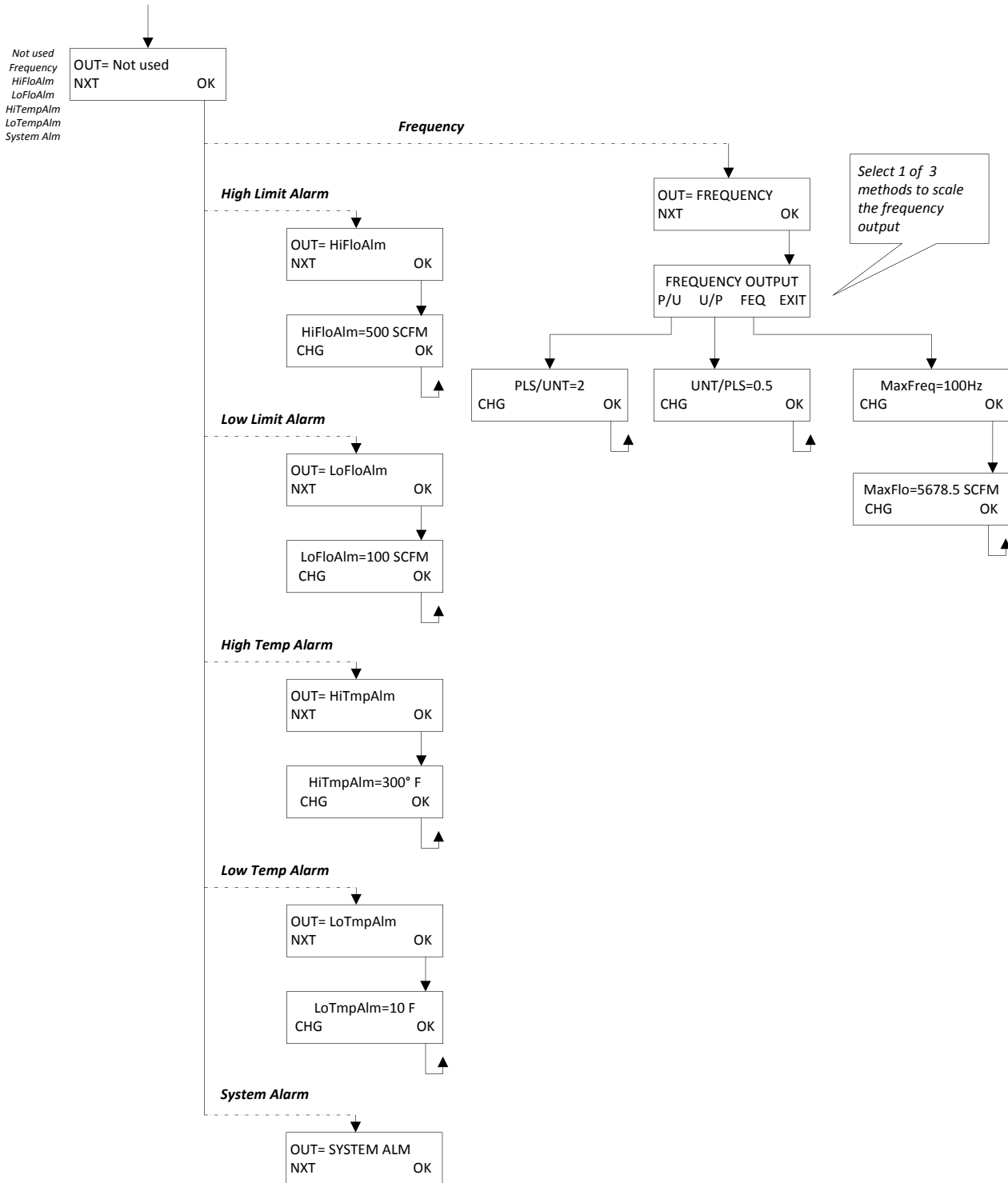

Operation

Fig. 4.7: FT3 Menu Tree - Parameter Menu 1

OPERATION

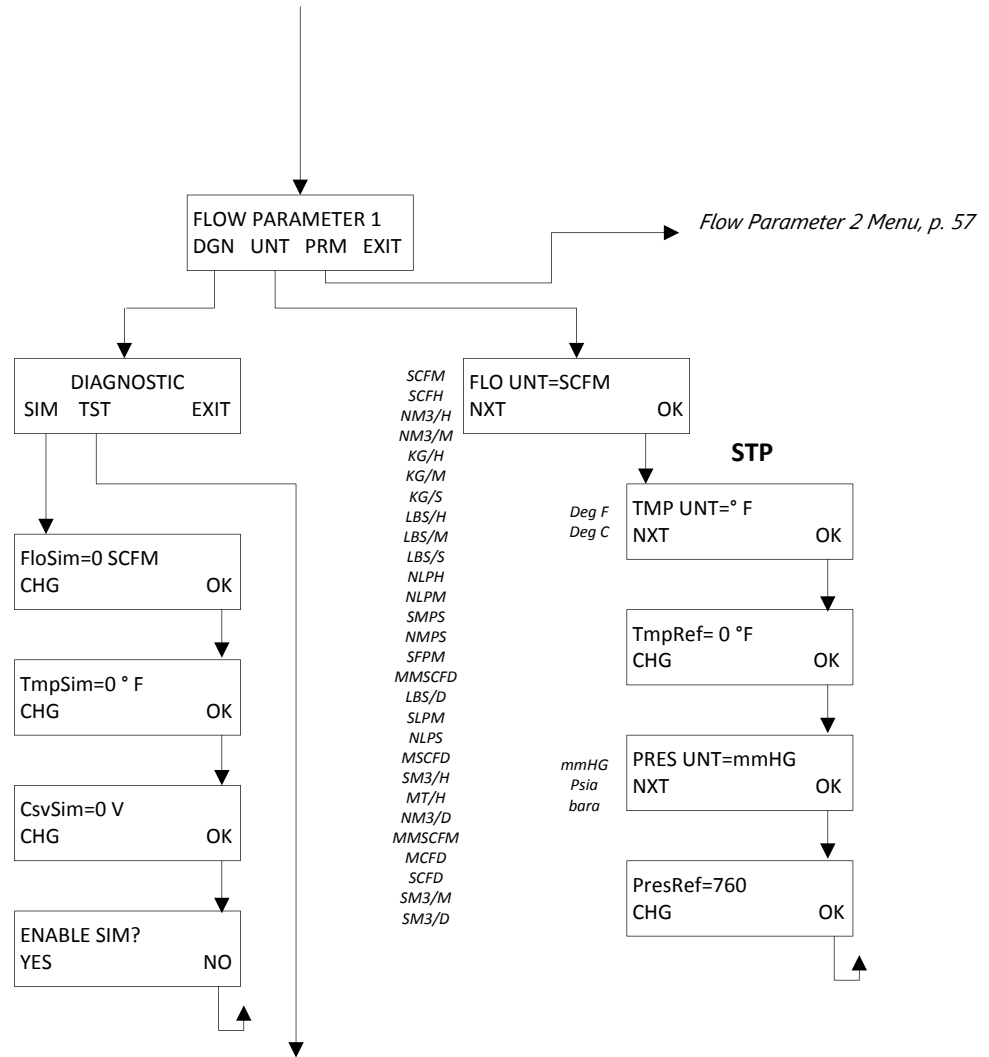

Note: simulation value needs to be greater than zero to be taken (i.e 0.0001 for a value close to zero)

Diagnostic Test Menu, p. 59

Flow Parameter 2 Menu, p. 57

Operation

Fig. 4.8: FT3 Menu Tree - Parameter Menu 2

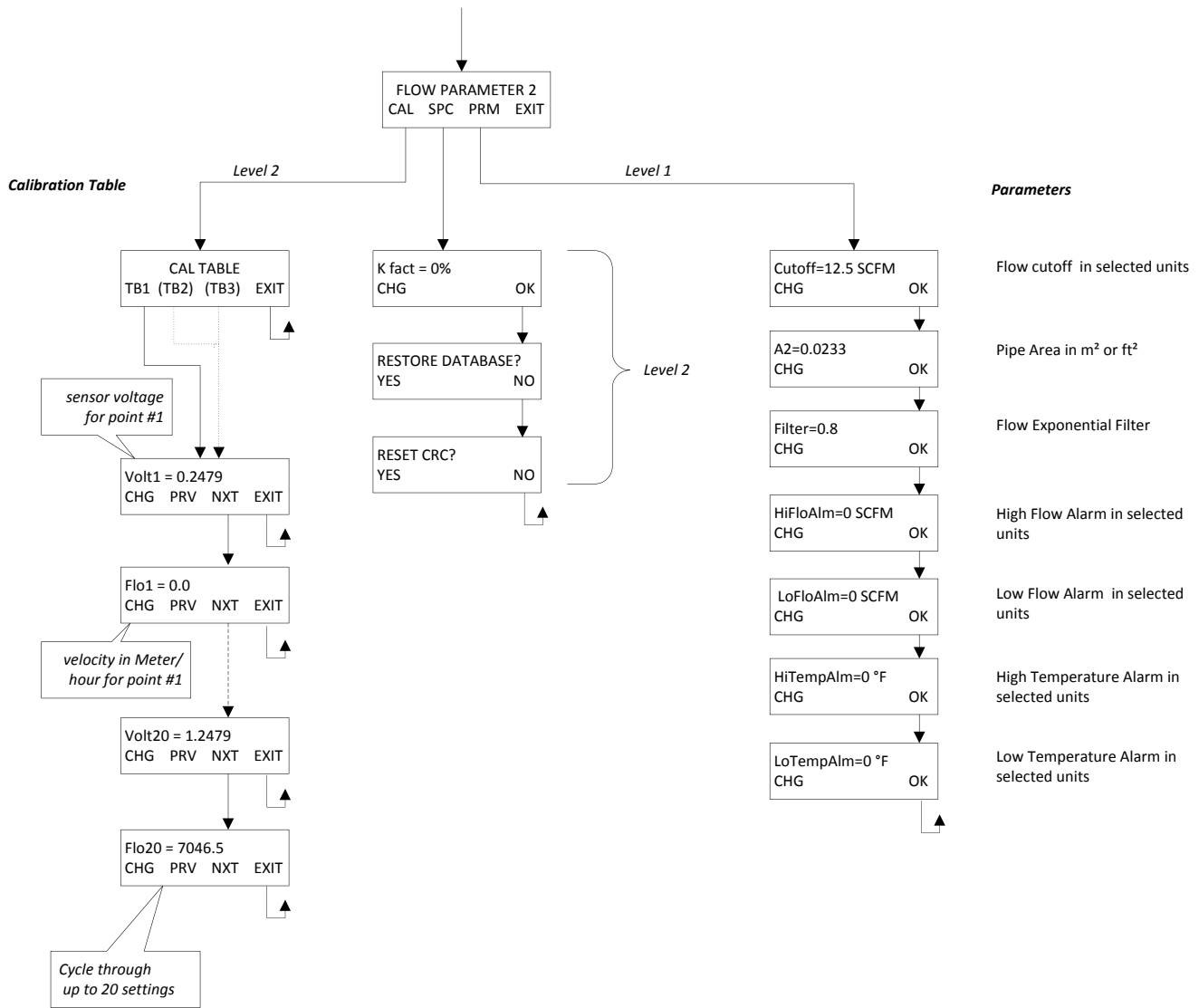

Operation

Fig. 4.9: FT3 Menu Tree - Display Menu

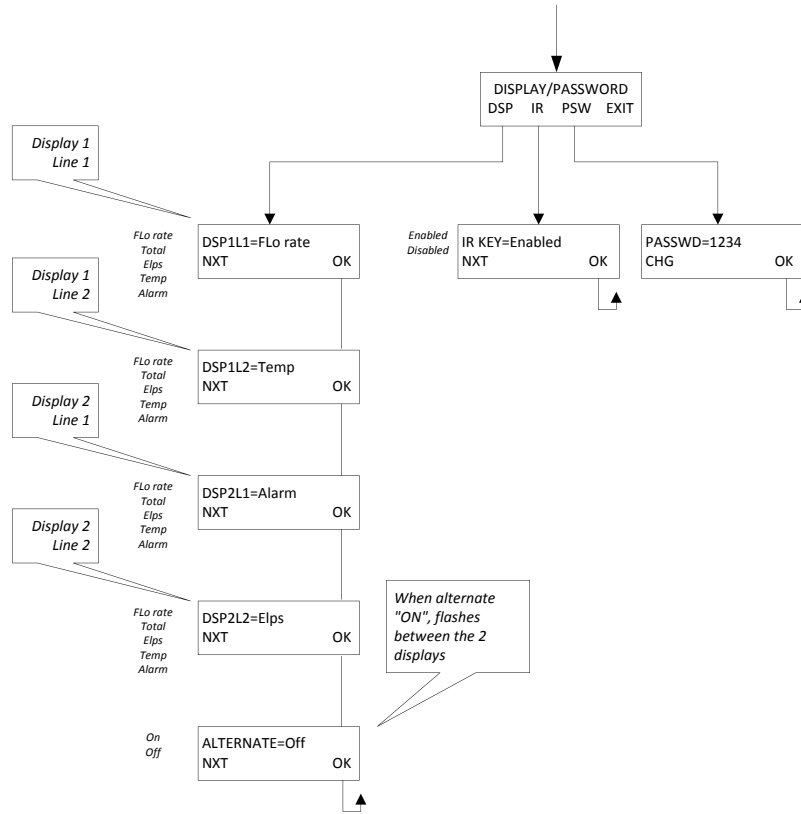

OPERATION



NOTE!

All readings updated every second

- Flo Rate = Flow rate of process gas
- Total = Total flow of process gas
- Elps = Elapsed time since reset of flow total
- Temp = Temperature of process gas
- Alarm = High/Low Flow Rate or Temperature Alarm

Operation

Fig. 4.10: FT3 Menu Tree - Diagnostic Tests Menu

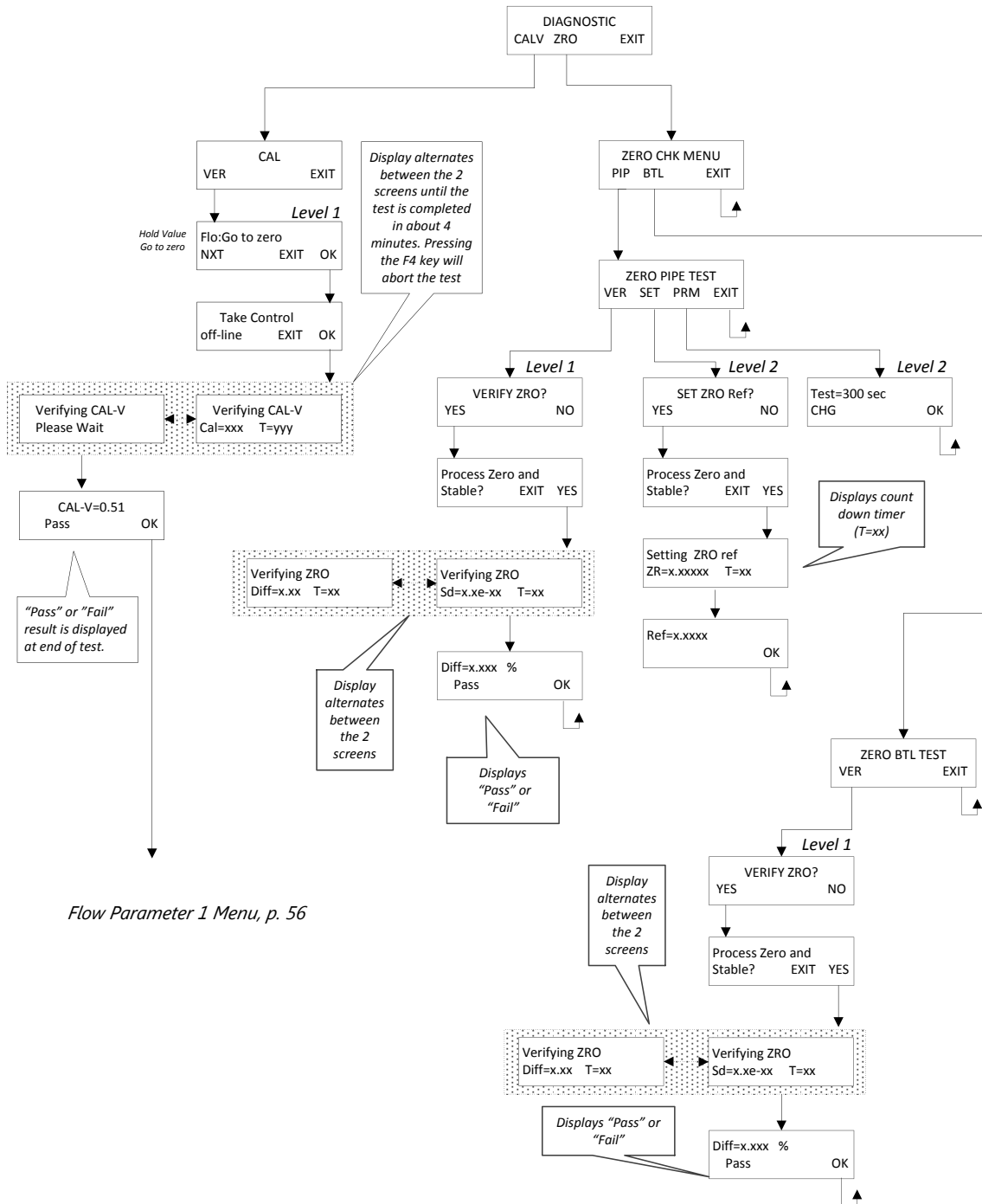

OPERATION

Maintenance

Precautions

GB



WARNING! BEFORE ATTEMPTING ANY MAINTENANCE, TAKE THE NECESSARY SAFETY PRECAUTIONS BEFORE REMOVING THE PROBE FROM THE DUCT (EXAMPLE: PURGE LINES OF TOXIC AND/OR EXPLOSIVE GAS, DEPRESSURIZE, ETC...).

WARNING! EXPLOSION HAZARD. DO NOT REMOVE OR REPLACE COMPONENTS OR FUSES UNLESS POWER HAS BEEN DISCONNECTED WHEN A FLAMMABLE OR COMBUSTIBLE ATMOSPHERE IS PRESENT.

WARNING! EXPLOSION HAZARD. DO NOT DISCONNECT EQUIPMENT WHEN A FLAMMABLE OR COMBUSTIBLE ATMOSPHERE IS PRESENT.

WARNING! TURN OFF INPUT POWER BEFORE REMOVING OR INSTALLING A CIRCUIT BOARD ASSEMBLY FROM THE ENCLOSURE.

Access to Electronics

Accessing electronics is not normally required for maintenance purposes. If a loose connection is suspected, unscrew the rear end-cap of the meter enclosure to access the terminations

CAUTION! BE SURE POWER TO METER IS SWITCHED OFF BEFORE ATTEMPTING TO ACCESS ELECTRONICS. If there is a problem and a loose connection is not found, please contact Fox Thermal Customer Service for technical assistance at (831) 384-4300.

Precauciones

ES



¡ADVERTENCIA! ANTES DE INTENTAR CUALQUIER MANTENIMIENTO, TOMÉ LAS PRECAUCIONES DE SEGURIDAD NECESARIAS ANTES QUE RETIRAR LA Sonda DEL DUCTO (EJEMPLO: PURGUE LAS LÍNEAS DE GASES TÓXICOS Y/O EXPLOSIVOS, DESPRESURICE, ETC...).

¡ADVERTENCIA! PELIGRO DE EXPLOSIÓN. NO RETIRE O REEMPLACE COMPONENTES O FUSIBLES A MENOS QUE LA ENERGÍA HAYA SIDO DESCONECTADA SIEMPRE QUE ESTÉ PRESENTE UNA ATMÓSFERA INFLAMMABLE O COMBUSTIBLE.

¡ADVERTENCIA! PELIGRO DE EXPLOSIÓN. NO DESCONECTE NINGÚN EQUIPO CUANDO UNA ATMÓSFERA INFLAMABLE O COMBUSTIBLE ESTÉ PRESENTE PRONTO.

¡ADVERTENCIA! DESCONECTE LA ENERGÍA DE ALIMENTACIÓN ANTES DE REMOVER O INSTALAR UN ENSAMBLE DE TARJETA DE CIRCUITO DEL GABINETE.

Acceso a la Electrónica

Normalmente no se requiere tener acceso a la electrónica para propósitos de mantenimiento. Si se sospecha de una conexión suelta, desatornille la tapa posterior de la caja del medidor para tener acceso a las terminales

PRECAUCIÓN: ASEGÚRESE QUE LA ALIMENTACIÓN DEL MEDIDOR ESTE DESCONECTADA ANTES DE INTENTAR EL ACCESO A LA ELECTRÓNICA. Si existe algún problema y no se encuentra ninguna conexión suelta, por favor póngase en contacto con el Servicio al Cliente de Fox Thermal para asistencia técnica al número (831) 384-4300.

Maintenance

Précautions



FR

AVERTISSEMENT ! AVANT TOUTE TENTATIVE DE MAINTENANCE, OBSERVER LES CONSIGNES DE SECURITE NECESSAIRES AVANT DE RETIRER LA SONDÉ DE LA CONDUITE (PAR EXEMPLE, PURGER LES LIGNES DES GAZ EXPLOSIFS/TOXIQUES QU'ELLES POURRAIENT CONTENIR, DEPRESSURISER LE CONTENEUR, ETC.).

AVERTISSEMENT ! RISQUE D'EXPLOSION. NE PAS RETIRER NI REMPLACER DES COMPOSANTS OU DES FUSIBLES SI LA SOURCE D'ALIMENTATION N'A PAS ÉTÉ DEBRANCHÉE DANS UNE ATMOSPHÈRE INFLAMMABLE OU COMBUSTIBLE.

AVERTISSEMENT ! RISQUE D'EXPLOSION. NE PAS DEBRANCHER UN ÉQUIPEMENT DANS UNE AMBIANCE COMBUSTIBLE OU INFLAMMABLE.

AVERTISSEMENT ! COUPER L'ALIMENTATION AVANT DE RETIRER OU D'INSTALLER UN ENSEMBLE DE CARTE DE CIRCUITS IMPRIMÉS DU BOÎTIER.

Accès aux composants électroniques

L'accès aux composants électroniques n'est généralement pas nécessaire dans le cadre de la maintenance. Si une connexion lâche est suspectée, dévisser le capuchon d'extrémité arrière du boîtier du compteur pour accéder aux terminaisons

ATTENTION : S'ASSURER QUE L'ALIMENTATION DU COMPTEUR EST COUPEE AVANT D'ACCÈS AUX COMPOSANTS ÉLECTRONIQUES. En cas de problème et qu'aucune connexion lâche n'est détectée, veuillez contacter le service client de Fox Thermal pour obtenir une assistance technique au (831) 384-4300.

Vorsichtsmaßnahmen



DE

ACHTUNG! BITTE ERGREIFEN SIE DIE ERFORDERLICHEN SICHERHEITSMÄßNAHMEN, BEVOR SIE IRGENDWELCHE WARTUNGSARBEITEN DURCHFÜHREN UND DIE MESSSONDE AUS DEM ROHR ENTFERNEN (BEISPIEL: LEITUNGEN ZUR ENTFERNUNG VON GIFTIGEN UND/ODER EXPLOSIVEN GASEN REINIGEN, DRUCK SENKEN, USW.).

ACHTUNG! EXPLOSIONSGEFAHR. KOMPONENTEN ODER SICHERUNGEN BITTE ERST DANN ENTFERNEN ODER AUSTAUSCHEN, WENN DER STROM GETRENNT WURDE, FALLS EINE ENTZÜNDLICHE ODER BRENNBARE ATMOSPHÄRE VORHANDEN IST.

ACHTUNG! EXPLOSIONSGEFAHR. GERÄT NICHT VOM STROM TRENNEN, WENN EINE ENTZÜNDLICHE ODER BRENNBARE ATMOSPHÄRE VORHANDEN IST.

ACHTUNG! EINGANGSLEISTUNG AUSSCHALTEN, BEVOR LEITERPLATTENBAUGRUPPEN AUS DEM GEHÄUSE AUSGEBAUT ODER IN DIESES EINGEBAUT WERDEN.

Zugriff auf die Elektronik

Der Zugriff auf die Elektronik ist zu Wartungszwecken normalerweise nicht erforderlich. Falls eine lose Verbindung vermutet wird, schrauben Sie die hintere Endkappe des Messgerätgehäuses ab, um auf die Anschlüsse zugreifen zu können.

VORSICHT: STELLEN SIE SICHER, DASS DER STROM AN DAS MESSGERÄT AUSGESCHALTET IST, BEVOR SIE VERSUCHEN, AUF DIE ELEKTRONIK ZUZUGREIFEN. Falls Probleme auftreten und keine lose Verbindung gefunden werden kann, wenden Sie sich bitte zwecks technischer Unterstützung an den Fox Thermal-Kundendienst unter der Nummer (831) 384-4300.

Maintenance

Broken or Damaged Probe

If the sensor is broken or damaged, the probe and electronics must be returned to the factory. A new sensor will be installed and calibrated. Refer to "Returning Your Meter" on p. 88.

Flow Calibration and Calibration Validation

To ensure continued high accuracy of your Model FT3 Flow Meter, Fox Thermal provides a full NIST-traceable calibration. The Model FT3 also features on-board calibration validation diagnostics called CAL-V™ and Zero CAL-CHECK®. If the CAL-V™ and Zero CAL-CHECK® tests pass, the sensor is measuring accurately and the meter does not require recalibration. However, if your quality or metrology systems require periodic recalibration in an NIST-traceable lab, it is recommended that the meter be returned to Fox Thermal for evaluation and calibration after every two years of operation.

Fuse Replacement

Verify the fuse is defective by measuring it with an Ohm Meter (Two replacement fuses are provided with each unit). The fuse F1 is located near the power terminal block and can be removed by using tweezers or needle-nose pliers. Replacement fuse is Littelfuse part number 0454.750MR.

WARNING!



- Turn input power OFF before removing or installing a fuse. Use only recommended fuse replacements.
- It is the user's responsibility to install the flow meter in an appropriately designed system with adequate safety protections.
- DO NOT remove the flow instrument from the flow body while the system is under flow conditions.
- This product may experience temperatures from as low as -40F (-40C) and as high as 649F (343C). It is the user's responsibility to take safety precautions regarding operating temperature of the flow meter.
- If large flow body has been purchased, user is advised to use a double sling to prevent rotation of flow body during installation or other method to prevent damage of flow instrument.

Sensor Wiring



NOTE! Sensor terminations are performed at the factory except when the Remote Electronics option is used or ordered.

Sensor Cleaning

The sensor is insensitive to small amounts of residue, but continued use in dirty environments will necessitate periodic cleaning. To inspect the sensor, remove power from electronics and remove the unit from the pipe or duct, exposing the sensor elements. If they are visibly dirty, clean them with water or alcohol (ethanol) using an appropriate brush until they appear clean again. Even though the sensor elements are rugged, avoid touching them with any solid object and use a light touch while cleaning them.

Troubleshooting

Troubleshooting



CAUTION! The electronics, sensor and sensor interconnect wires supplied by Fox Thermal are calibrated as a single precision mass flow meter. Interchanging sensors or sensor wiring will impair the accuracy of the flow meter.

If you experience any problem with your Model FT3 Flow meter, call Fox Thermal Customer Service Department, Technical Assistance at (831) 384-4300.

Problem	Possible Cause	Action
Display-Main Bd Comm. Error	Display and main board not communicating	Check status of LP1 on the Main Board and LP6 on the display board. Are green LEDs blinking once per second? If LEDs are not blinking, cycle power to reset meter. Call Fox Thermal Tech Support.
Meter does not read up to full scale	Calibration table may be corrupted	<ul style="list-style-type: none"> •Check the calibration table for a corrupted location. •Enter the password 9111. •Start on p. 41 of the FT3 manual and follow the steps to get to Flow Parameters 2 menu screen. •Select CAL (F1) •Select NXT (F1) to cycle through calibration table to verify entries match calibration certificate. •Check for CRC error code
Velocity measurement seems low	1.Probe not oriented properly 2.Sensor dirty	1.Orient probe per installation sections: Insertion (p. 8), Inline (p. 12). 2.Clean sensor (p. 62)

Troubleshooting

TROUBLESHOOTING

Problem	Possible Cause	Action
Unit will not power-up	a)No power input b)Bad fuse c)Bad Power supply	<ul style="list-style-type: none"> •Check fuse (F1) located next to TS1 on main board. •Check for correct power supply voltage at TS1 on main board. <p>If fuse is OK and unit still won't power up, call Fox Thermal for additional assistance</p>
Meter does not initialize	Electromechanical interference	<ul style="list-style-type: none"> •Check meter power cycles. •Press and release F1 and F2 at the same time; the display will enter Engineering screens. •Press F1 to get to screen #23; record power cycle value. •Press F4 to return to normal operation; monitor meter until problem returns. •Return to screen #23 to see if power cycles have increased; microprocessor is resetting due to EMI electrical noise entering the meter. •Check Power input and output cables grounding and routing.

Troubleshooting

Problem	Possible Cause	Action
Velocity measurement is erratic or fluctuating	1. Very turbulent flow 2. Sensor dirty 3. Sensor broken 4. Probe not mounted securely 5. Malfunction in flow meter 6. Meter installed incorrectly	1. Increase dampening (see filter settings in "Flow Parameters" on p. 41) 2. Clean sensor (Refer to Maintenance section, p. 62) 3. Return flow meter to Fox Thermal for repair (Refer to p. 88 for shipping instructions) 4. Remount probe (see Installation section, p. 8 and p. 12); must be mounted securely without vibration. If vibration persists, choose a new mounting location without location. 5. Return flow meter to Fox Thermal for repair (Refer to p. 88 for shipping instructions) 6. Re-install meter according to instructions (Refer to installation section, p. 8 and p. 12)

Troubleshooting

Installation Problems

The following is a summary listing of problems that may be encountered with the installation of the FT3 Thermal Mass Flow Meter.

1. Improper wiring connections for power and/or 4-20mA output signal.
The FT3 requires a separate power source for the main board and the two 4-20mA output signals. Two wires supply 24VDC power to the main board. Two wires are used for each of the 4-20mA output signals. Refer to Figure 3.4 and Figure 3.5 (p. 19). Also refer to "Wiring Precautions" and "Helpful Hints" in Wiring section (p. 14) for further guidance.
2. Inadequate power source.
For those models that are powered by 24VDC, a 24VDC $\pm 10\%$, 0.7 Amp or greater power supply is recommended. If the voltage supplied is not within this range or if the power supply is not rated for 25 watts minimum, a variety of problems can occur including inaccurate flow readings, dim display and faulty programming action. The input voltage must be within the range of 21.6 to 26.4VDC as measured at the power input terminals of the flow meter electronics.
3. Flow measurement seems inaccurate.
 - Check to ensure that the flow meter is installed so that the Flow Direction Arrow engraved on the flat surface of the fitting below the electronics housing is properly pointing in the direction of flow. Refer to Figure 2.7 (p. 12). If not, change orientation of meter.
 - If you have a Fox Thermal insertion type flow meter, check that the insertion depth of the sensor/probe is correct. The end of the probe should be adjusted as per Figure 2.2 (p. 9).
 - For inline meter types, ensure that there are a minimum of ten diameters of straight pipe upstream of the sensor and five diameters downstream ($\frac{1}{4}$ " meters: 6" [152 mm] of straight, unobstructed pipe upstream and downstream required). For insertion meter types, ensure that there are a minimum of fifteen diameters of straight pipe upstream of the sensor and ten diameters downstream. If complex flow disturbances are upstream of the sensor, extension of the straight pipe may be required to ensure accurate flow measurement. Contact Fox Thermal for assistance.
 - Ensure that pipe area data in the meter matches data on the Fox Thermal Calibration Certificate. The pipe internal cross sectional area is programmed into the flow meter through the front panel (see Flow Parameters, p. 41). This area is programmed in square feet or square meters. The Calibration Certificate delivered with the flow meter contains the area that was programmed into the flow meter at the Fox Thermal factory. Check to ensure that this area is correct.
4. Erratic flow reading especially a flow reading spiking high.
This may be a symptom of moisture in the flow stream. Fox Thermal flow meters are designed to work in relatively dry gas applications only. Contact Fox Thermal to discuss resolutions to this problem.

Troubleshooting

5. Flow meter is not responding to flow.

This problem could be caused by a number of reasons:

- Check to ensure adequate power is supplied to the flow meter as described above. If things appear to be correct, an easy functional test can be performed. Carefully remove the probe and sensor from the pipe or flow body. **CAUTION!** the sensor is HOT. For those flow meters with a display - and if the display is reading zero - blow on the sensor to see if a response occurs. If nothing happens, take a damp rag or sponge and place it in contact with the sensor. A reading should occur. Contact Fox Thermal Customer Service with this information.
- A corrupted calibration table may lead to a zero flow reading. Verify that all Cal Flow Parameter settings are correct by accessing the "Calibration Parameters" information on meter (see p. 44). Check meter data for any non-whole numbers and call customer service for assistance.

6. Display and/or 4-20mA signal reading above zero flow when no flow is occurring in the pipe.

If the reading is less than 5% of full scale, it is likely this is a normal condition caused by convection flow created by the heated sensor. It does not mean that the zero of the instrument is improperly set. The Fox Thermal sensor is extremely sensitive to gas flow and can even read the small flow caused by convection. If this is an unacceptable condition, please contact Fox Thermal Customer Service for alternatives.

7. Mismatched serial numbers

If you have more than one meter, you must ensure that the serial numbers of meter, remote, and/or flow body match one another. These items have been manufactured and calibrated to operate as a unit and cannot be mismatched.

Troubleshooting

Alarm Codes

Information to diagnose and clear alarm codes is on p. 57 under the Menu Tree section. Enter password (9111) and follow the block diagram to get to the section affected by the error code.

Alarm Code	Reason	Action
13	Flow rate above high limits	Refer to the PARAMETER MENU 2 section on p. 41 of this Manual to verify limit is within range. Check ALM = HiFloAlm under PRM.
14	Flow rate below low limits	Refer to the PARAMETER MENU 2 section on p. 41 of this Manual to verify limit is within range. Check ALM = LoFloAlm under PRM.
15	Temperature above high limits	Refer to the PARAMETER MENU 2 section on p. 41 of this Manual to verify limit is within range. Check ALM=HiTempAlm under PRM.
16	Temperature below low limits	Refer to the PARAMETER MENU 2 section on p. 41 of this Manual to verify limit is within range. Check ALM = LoTempAlm
22	Sensor out of range	Refer to the ENGINEERING DISPLAY MENU on p. 28 of this Manual and the Fox Thermal factory Calibration Certificate to check CSV voltage. Compare Display 10 value to Calibration Certificate CSV voltage and verify it's within range.
23	Velocity out of calibration table range	Refer to the ENGINEERING DISPLAY MENU on p. 28 of this Manual and the Fox Thermal factory Calibration Certificate to check CSV voltage. Compare Display 10 value to Calibration Certificate CSV voltage and verify it's within range.
24	Check settings	One or more internal settings are corrupted or out of spec. Contact Fox Thermal Service for instructions to verify settings.
25	Simulation mode	Meter is in Simulation Mode. Refer to the PARAMETER MENU 1 section on p. 46 of this Manual. Use the SIM Section under Diagnostics to return to normal operation.
26	Frequency output over range	Refer to the DIGITAL OUTPUT MENU on p. 55 of this Manual. Verify the Frequency Output settings are within limits.
32	4-20mA for flow rate is out of range	Refer to the MAIN MENU on p. 54 of this Manual. Use the Set I/O section to verify range limits under FLO Set 4-20mA.
33	4-20mA for temperature is out of range	Refer to p. 43 of this Manual. Use the Set I/O section to verify range limits under FLO Set 4-20mA. Channel #2 can be set for flow or temperature.
34	Busy	Meter is recalculating new parameters.

Troubleshooting

Alarm Code	Reason	Action
35	Sensor Bridge Shutdown	The FT3 probe is getting too hot in the FT3 electronic enclosure and remote enclosure. Check sensor wiring.
36	Database CRC Error	Refer to the PARAMETER MENU 2 section on p. 41 of this Manual to reset CRC. Use SPC section of menu to reset CRC. Contact Fox Thermal Service Department for possible causes.
37	Totalizer Error Detected	See "Reset the Total and Elapsed Time" on p. 45 for steps to clear Error Code. Contact Fox Thermal for possible causes.
38	CAL-V™ in progress	Wait until the CAL-V™ or Cal Set is finished.
39	ADC12 versus ADC24 too far	The tolerance between the 2 ADC is out of specification. Recalling manufacture default may correct the problem.
40	CAL-V™ Diff Fail	The CAL-V™ Diff Failed. Check sensor wiring and verify that the sensor's resistance is correct. Call Tech Support.
41	Zero CAL-CHECK® Fail	Allow meter to stabilize for 15 minutes and perform the test again. If another "Fail" test results, call Tech Support.

Dimensions

Fig. 6.1 Local Insertion Meter with Retractor Dimensions

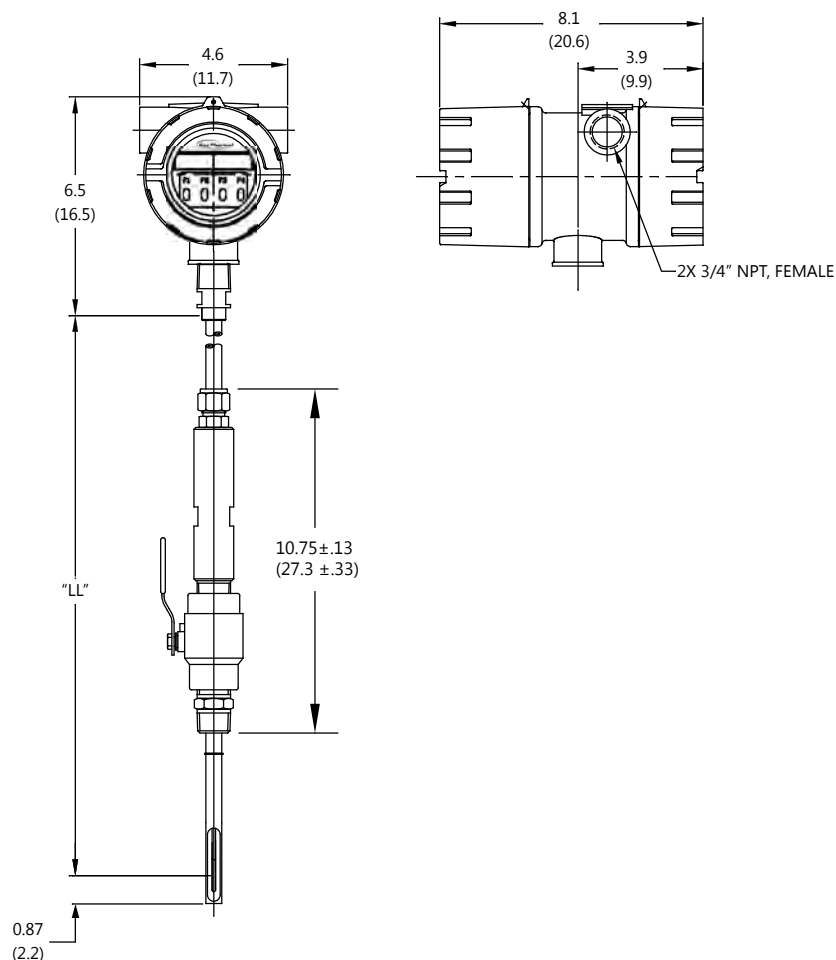

Table 6.1 Local Insertion Meter with Retractor

Probe Size	Probe Size	Dimension "LL"
[model code]	[inches]	[inches/centimeters]
15R	15"	15.0" (38.1cm)
18R	18"	18.0" (45.7cm)
24R	24"	24.0" (61.0cm)
30R	30"	30.0" (76.2cm)
36R	36"	36.0" (91.4cm)

DIMENSIONS

Dimensions

Fig. 6.2 Remote Insertion Meter with Retractor Dimensions

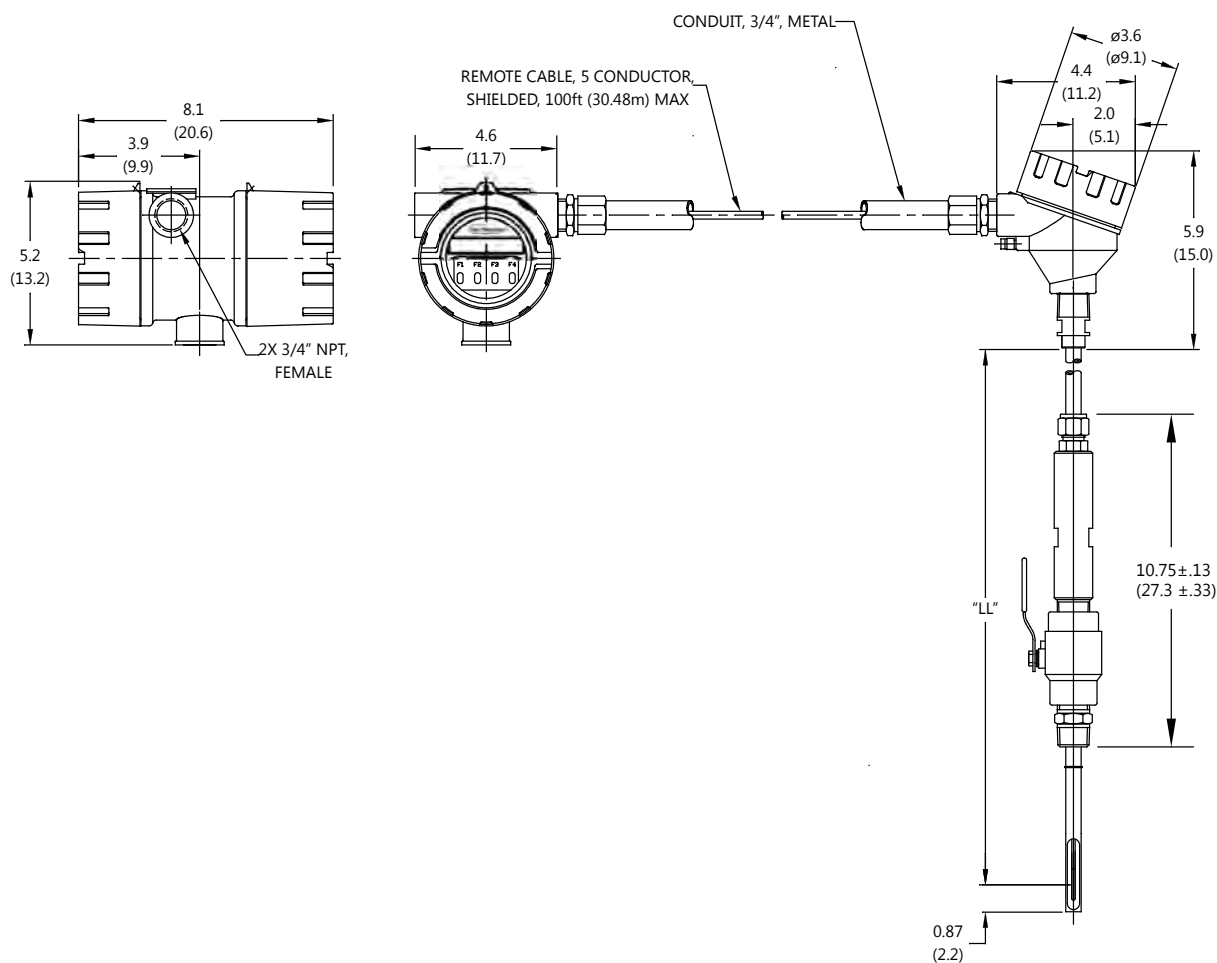

DIMENSIONS

Table 6.2 Remote Insertion Meter with Retractor

Probe Size	Probe Size	Dimension "LL"
[model code]	[inches]	[inches/centimeters]
15R	15"	15.0" (38.1cm)
18R	18"	18.0" (45.7cm)
24R	24"	24.0" (61.0cm)
30R	30"	30.0" (76.2cm)
36R	36"	36.0 " (91.4cm)

Dimensions

Fig. 6.3 Insertion Meter Dimensions

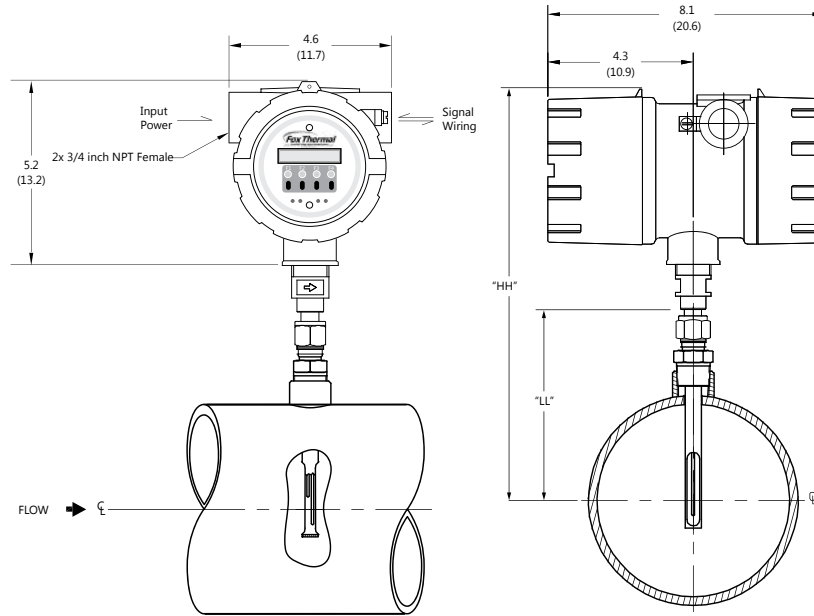
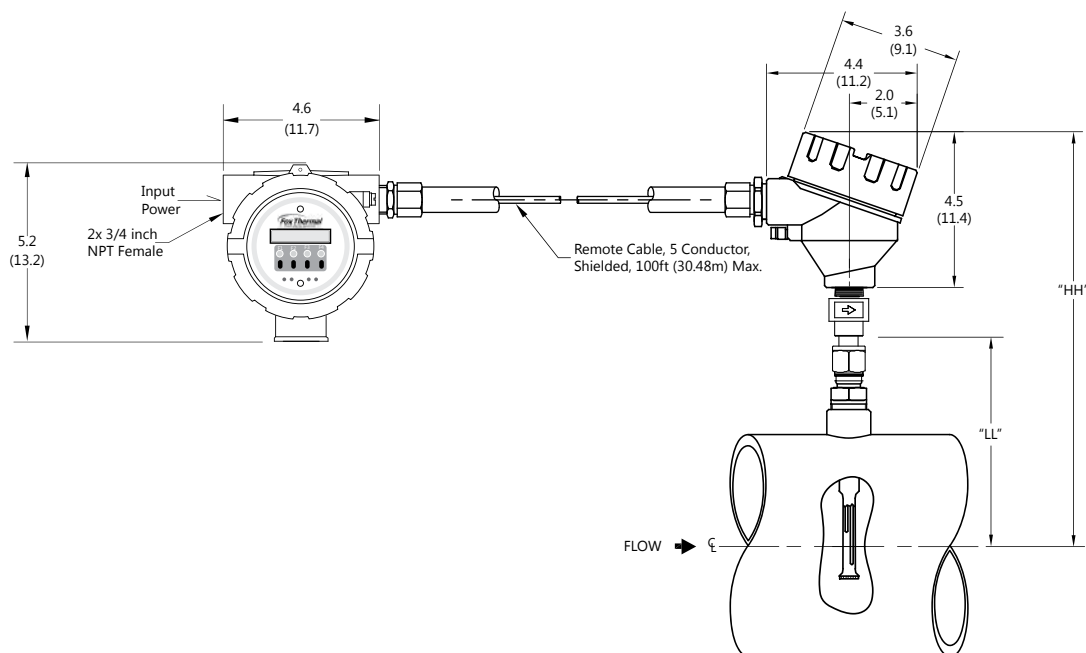

Table 6.3 Insertion Meter with 316 stainless steel probe

Probe Size [model code]	Probe Size [inches]	Dimension "LL" [inches/centimeters]	Dimension "HH" [inches/centimeters]
06I	6"	6.0" (15.2cm)	12.5" (31.8cm)
09I	9"	9.0" (22.9cm)	15.5" (39.4cm)
12I	12"	12.0" (30.5cm)	18.5" (47.0cm)
15I	15"	15.0" (38.1cm)	21.5" (54.6cm)
18I	18"	18.0" (45.7cm)	24.5" (62.2cm)
24I	24"	24.0" (61.0cm)	30.5" (77.5cm)
30I	30"	30.0" (76.2cm)	36.5" (92.7cm)
36I	36"	36.0" (91.4cm)	42.5" (108.0cm)

Dimensions

Fig 6.4: Insertion Remote Meter Dimensions



DIMENSIONS

Table 6.4 Insertion Remote Meter with 316 stainless steel probe

Probe Size [model code]	Probe Size [inches]	Dimension "LL" [inches/centimeters]	Dimension "HH" [inches/centimeters]
06I	6"	6.0" (15.2cm)	11.9" (30.2cm)
09I	9"	9.0" (22.9cm)	14.9" (37.9cm)
12I	12"	12.0" (30.5cm)	17.9" (45.5cm)
15I	15"	15.0" (38.1cm)	20.9" (53.1cm)
18I	18"	18.0" (45.7cm)	23.9" (60.7cm)
24I	24"	24.0" (61.0cm)	29.9" (76.0cm)
30I	30"	30.0" (76.2cm)	35.9" (91.2cm)
36I	36"	36.0" (91.4cm)	41.9" (106.4cm)

Dimensions

Fig. 6.5: Inline Meter with 316 Stainless Steel Flow Body and NPT End Connections Dimensions

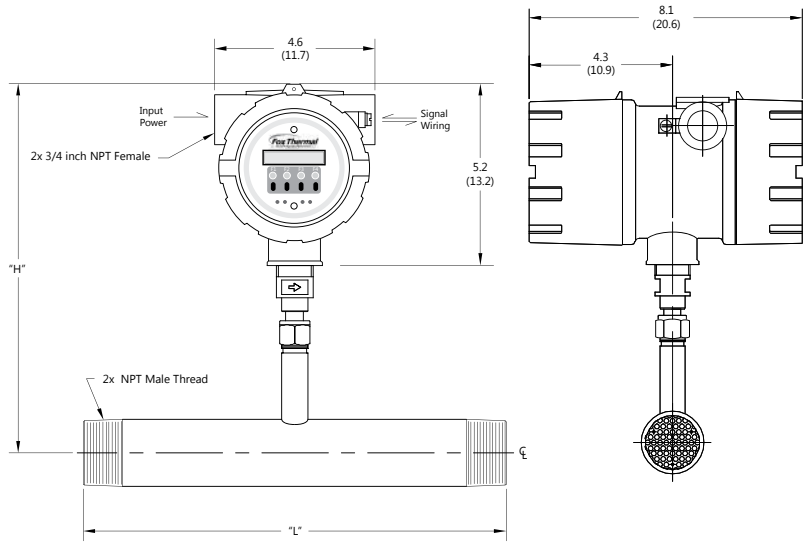

DIMENSIONS

Table 6.5 Inline Meter with 316 stainless steel flow body and NPT End Connections

Body Size [model code]	Body Size [inches]	Dimension "L" [inches]	Dimension "H" [inches/centimeters]
025P	0.25"	5.8"	10.5" (26.7cm)
05P	0.50"	12"	10.5" (26.7cm)
075P	0.75"	12"	10.5" (26.7cm)
10P	1.00"	12"	10.5" (26.7cm)
125P	1.25"	12"	10.5" (26.7cm)
15P	1.50"	12"	10.5" (26.7cm)
20P *	2.00"	12"	10.5" (26.7cm)
25P *	2.50"	18"	10.6" (26.9cm)
30P *	3.00"	18"	12.5" (31.8cm)
40P *	4.00"	18"	12.5" (31.8cm)

* Also available in A106 Grade B carbon steel pipe (20PC, 25PC, 30PC, and 40PC model codes)

Dimensions

Fig. 6.6: Inline Remote Meter with 316 Stainless Steel Flow Body and NPT End Connections Dimensions

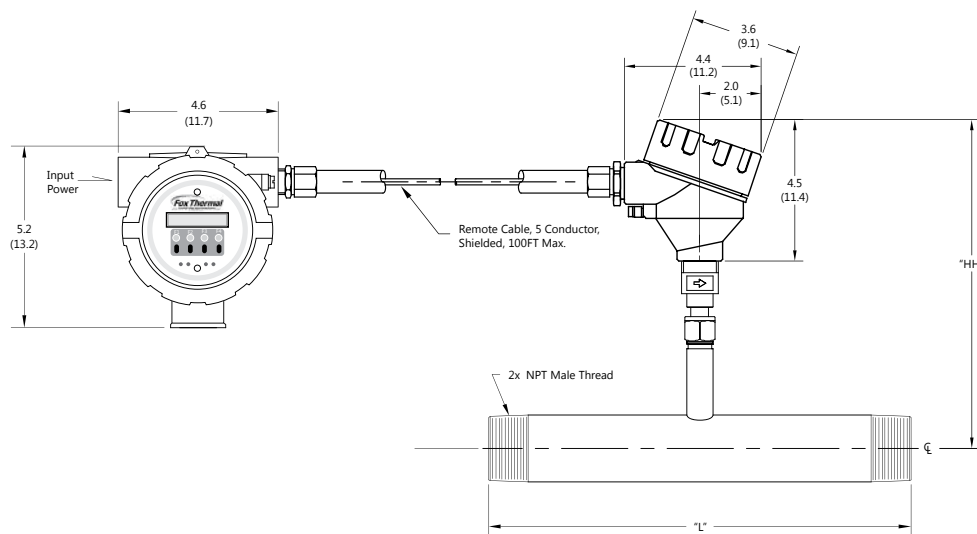

DIMENSIONS

Table 6.6 Inline Remote Meter with 316 stainless steel flow body and NPT End Connections

Body Size [model code]	Body Size [inches]	Dimension "L" [inches]	Dimension "HH" [inches/centimeters]
05P	0.50"	12"	10.5" (26.7cm)
075P	0.75"	12"	10.5" (26.7cm)
10P	1.00"	12"	10.5" (26.7cm)
125P	1.25"	12"	10.5" (26.7cm)
15P	1.50"	12"	10.5" (26.7cm)
20P *	2.00"	12"	10.5" (26.7cm)
25P *	2.50"	18"	10.6" (26.9cm)
30P *	3.00"	18"	12.5" (31.8cm)
40P *	4.00"	18"	12.5" (31.8cm)

* Also available in A106 Grade B carbon steel pipe (20PC, 25PC, 30PC, and 40PC model codes)

Dimensions

Fig. 6.7: Inline Meter with 316 Stainless Steel Flow Body and 150lb RF Flange End Connections Dimensions

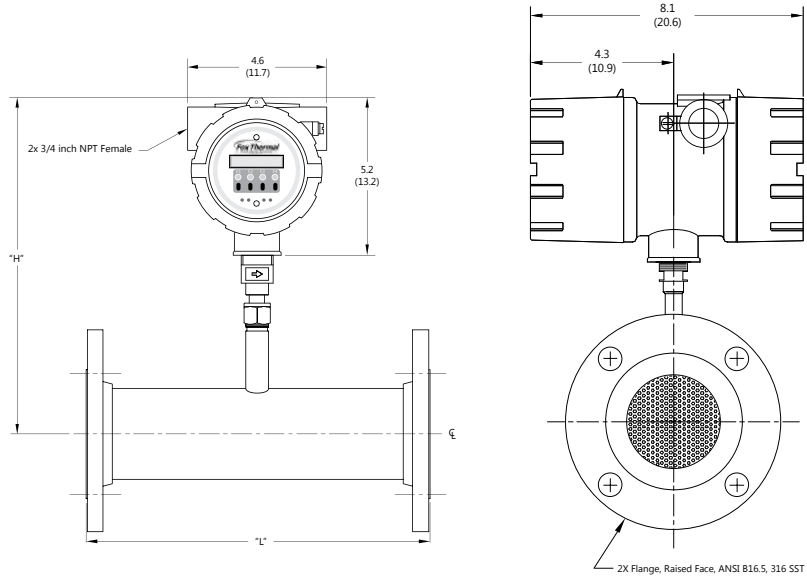

DIMENSIONS

Table 6.7 Inline Meter with 316 stainless steel flow body and 150lb RF Flange End Connections

Body Size [model code]	Body Size [inches]	Dimension "L" [inches]	Dimension "H" [inches/centimeters]
05F	0.50"	12"	10.5" (26.7cm)
075F	0.75"	12"	10.5" (26.7cm)
10F	1.00"	12"	10.5" (26.7cm)
125F	1.25"	12"	10.5" (26.7cm)
15F	1.50"	12"	10.5" (26.7cm)
20F *	2.00"	12"	10.5" (26.7cm)
25F *	2.50"	18"	10.6" (26.9cm)
30F *	3.00"	18"	12.5" (31.8cm)
40F *	4.00"	18"	12.5" (31.8cm)
60F	6.00"	24"	12.5" (31.8cm)

* Also available in A106 Grade B carbon steel pipe with A105 flanges (20FC, 25FC, 30FC, and 40FC model codes)

Dimensions

Fig. 6.8: Inline Remote Meter with Stainless Steel Flow Body and 150lb RF Flange End Connections Dimensions

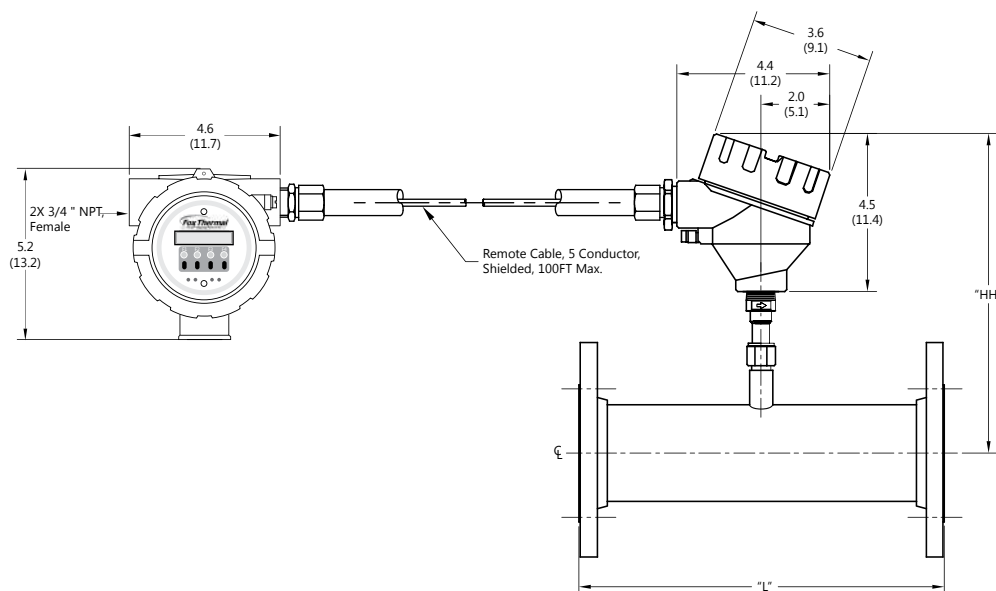

DIMENSIONS

Table 6.8 Inline Remote Meter with stainless steel flow body and 150lb RF Flange End Connections

Body Size [model code]	Body Size [inches]	Dimension "L" [inches]	Dimension "HH" [inches/centimeters]
05F	0.50"	12"	10.5" (26.7cm)
075F	0.75"	12"	10.5" (26.7cm)
10F	1.00"	12"	10.5" (26.7cm)
125F	1.25"	12"	10.5" (26.7cm)
15F	1.50"	12"	10.5" (26.7cm)
20F *	2.00"	12"	10.5" (26.7cm)
25F *	2.50"	18"	10.6" (26.9cm)
30F *	3.00"	18"	12.5" (31.8cm)
40F *	4.00"	18"	12.5" (31.8cm)
60F	6.00"	24"	12.5" (31.8cm)

* Also available in A106 Grade B carbon steel pipe with A105 flanges (20FC, 25FC, 30FC, and 40FC model codes)

Appendices

Performance Specs

Flow Accuracy:

Inline Meter: $\pm 1\%$ of reading $\pm 0.2\%$ of full scale.

¼" size: 6" (152 mm) of straight, unobstructed pipe upstream and downstream required.

All other sizes: 8 diameters of straight, unobstructed pipe upstream and 4 downstream required.

Insertion Meter: $\pm 1\%$ of reading $\pm 0.2\%$ of full scale.

15 diameters of straight, unobstructed pipe upstream and 10 downstream required.

Flow Repeatability: $\pm 0.2\%$ of full scale

Flow Response Time: 0.9 seconds (one time constant)

Temperature Accuracy:

$\pm 1.8^\circ\text{F}$ ($\pm 1.0^\circ\text{C}$) -40 to 250° F (-40 to 121° C); $\pm 3.6^\circ\text{F}$ ($\pm 2.0^\circ\text{C}$), 250 to 650° F (121 to 343° C); 60 SFPM minimum.

Calibration:

Factory Calibration to NIST traceable standards

CAL-V™ & Zero CAL-CHECK®: In situ, operator-initiated calibration validation

Operating Specs

Units of Measurement (field selectable):

SCFM, SCFH, NMPS, NM3/M, NM3/H, NM3/D, NLPS, NLPM, NLPH, SCFD, MSCFD, MMSCFD, MMSCFM, SMPS, SM3/D, SM3/H, SM3/M, LB/S, LB/M, LB/H, LB/D, KG/S, KG/M, KG/H, SLPM, SFPM, MT/H, MCFD

Relative Humidity: 90% RH maximum; non-condensing

Flow Rates for Insertion Flow Meter:

15 to 60,000 SFPM (0.07 to 280 NMPS) - Air at 70°F (20°C) & 1 ATM

Turndown: up to 1000:1; 100:1 typical

Typical Flow Ranges for Insertion Flow Meters		
Pipe size	SCFM	NM ³ /hr
1.5" (40mm)	0 - 840	0 - 1,325
2" (50mm)	0 - 1,400	0 - 2,210
2.5" (62mm)	0 - 2,000	0 - 3,150
3" (80mm)	0 - 3,100	0 - 4,890
4" (100mm)	0 - 5,300	0 - 8,360
6" (150mm)	0 - 12,000	0 - 18,930
8" (200mm)	0 - 20,840	0 - 32,870
10" (250mm)	0 - 32,800	0 - 51,740
12" (300mm)	0 - 46,600	0 - 73,500

APPENDICES

Appendices

Full Scale Flow Ranges for In-Line Flow meters:

Size	SCFM	NM ³ /hr
0.25"	0 - 7.5	0 - 11.8
0.5"	0 - 125	0 - 200
0.75"	0 - 220	0 - 350
1"	0 - 360	0 - 570
1.25"	0 - 625	0 - 990
1.5"	0 - 840	0 - 1,325
2"	0 - 1,400	0 - 2,210
2.5"	0 - 2,000	0 - 3,150
3"	0 - 3,100	0 - 4,890
4"	0 - 5,300	0 - 8,360
6"	0 - 12,000	0 - 18,930



NOTE! Standard conditions of air at 70°F and one atmosphere. Consult factory for other gases and for flow ranges above those listed. Inline meters above 2,500 SCFM (4,250 NM3/H) air may require third party Calibration. Contact Fox Thermal.

Gas Pressure (maximum):

Insertion: 500 psig (34.5 barg)

Inline (1/4" through 6"): NPT 500 psig (34.5 barg); 150lb flange 230 psig (16 barg)

Check with factory for higher pressure options.



NOTE! Pressure ratings stated for temperature of 100°F (38°C).

Maximum Altitude: 6,562ft (2,000m) max.

Temperature:

ST sensor: -40 to 250°F (-40 to 121°C)

HT Sensor: -40 to 650°F (-40 to 343°C)

Enclosure:

Without display or AC power supply: -40 to 158°F (-40 to 70°C)

With display and/or AC power supply: -4 to 158°F, (-20 to 70°C)

Remote sensor junction box: -40 to 212°F (-40 to 100°C).

Input Power:

24 VDC \pm 10%, 0.7 Amps (standard DC power)

100 to 240VAC \pm 10%/-15%, 50-60Hz, 0.2 Amps (with AC power option)



NOTE! Fluctuations of AC and DC power supply are not to exceed \pm 10% of rating.

Appendices

Class I Equipment (Electrical Grounding Required for Safety).
Installation (Over-voltage) Category II for transient over-voltages.

Outputs:

Two isolated 4-20mA outputs (output one is for flow rate and output two is programmable for flow rate or temperature); fault indication per NAMUR NE43.

Isolated pulse output 0 to 100Hz, 5 to 24 volts p/p for flow (the pulse output can be used as an isolated solid state output for alarms); 20mA max.

Serial Communication:

USB communication port is standard. The free PC-based software tool - FT3 View™ - provides complete configuration, remote process monitoring, and data logging functions.

Optional serial communication: HART and RS485 Modbus.

4-20mA Loop Verification:

Simulation mode used to align 4-20mA output with the input to customer's PLC/DCS.

Physical Specs

Sensor material: 316 stainless steel standard; Hastelloy C276 optional

Enclosure:

NEMA 4X (IP67), aluminum, dual conduit entries with ¾" NPT or optional M20 x 1.5mm.

Cabling to remote enclosure: 5-conductor, 18 AWG, twisted, shielded, 100 feet maximum.

Retractor Assemblies:

Packing gland assembly: 125 psig (8.6 barg) max.

High pressure (crank) retractor: NPT 600 psig (41.4 barg), ANSI 150 flange & ANSI 300 flange, no valve supplied.

Insertion Flow Meter Installation:

Fox Thermal-supplied compression fitting connects to customer-supplied ¾" female coupling welded to pipe.

Agency Approvals

CE: Approved

EMC Directive; 2004/108/EC

Emissions and Immunity Testing: EN61326-1:2008

Low Voltage Directive (LVD): 2006/95/EC

Product Safety Testing: EN 61010-1: 2010

Pressure Equipment Directive: 97/23/EC

Weld Testing: EN ISO 15614-1 and EN ISO 9606-1, ASME B31.3

Appendices

FM and FMc: Approved

- Class I, Div. 1, Groups B, C, D;
- Class II, Div. 1, Groups E, F, G;
- Class III, Div. 1; T3C, Ta = -40°C to 70°C;
- Class I, Zone 1, AEx/Ex d IIB+H2 (T6, T4, or T1*); Ta = -20°C to 70°C; Type 4X (IP67)

ATEX (FM12ATEX0034X): Approved

- II 2 G Ex db IIB+H2 (T6, T4, or T1*) Gb Ta = -20°C to 70°C; IP67
- II 2 D Ex tb IIIC (T85°C, T135°C, or T450°C*) Db Ta = -20°C to 70°C; IP67

IECEX (IECEX FMG 12.0010X): Approved

- Ex db IIB+H2 (T6, T4, or T1*) Gb Ta = -20°C to 70°C; IP67
- Ex tb IIIC (T85°C or T135°C*) Db Ta = -20°C to 70°C; IP67**

ATEX and IECEX Standards:

- | | |
|-----------------------------|--------------------|
| EN 60079-0: 2012 + A11:2013 | IEC 60079-0: 2011 |
| EN 60079-1: 2014 | IEC 60079-1: 2014 |
| EN 60079-31: 2014 | IEC 60079-31: 2013 |
| EN 60529: 1991, +A1: 2000 | IEC 60529: 2001 |

Model Code		Temperature Code Marking (Gas)		Temperature Code Marking (Dust)	
Enclosure	Sensor Type	Main Enclosure	Remote Enclosure	Main Enclosure	Remote Enclosure**
E1	ST	T4	N/A	135°C	N/A
E2	ST	T4	N/A	135°C	N/A
E3	ST	T6	T4	85°C	135°C**
E4	ST	T6	T4	85°C	135°C**
E3	HT	T6	T1	85°C	450°C**
E4	HT	T6	T1	85°C	450°C**

*Temperature code ratings for Zones are dependent on external process temperature factors and equipment enclosure configuration. See the table above for specific temperature code ratings.

**The IECEX dust rating does not apply to the Remote Enclosure.



NOTE! The EU Pressure Equipment Directive (PED) requires that the minimum ambient and fluid temperature rating for carbon steel flow bodies not be below -29C.

Appendices

Scope: FT3 with 2 Gas Curves

This section describes added features to the standard FT3 flow meter when using the 2 gas curves firmware option.

FT3 2 Gas Curves

The 2 Gas Curves firmware allows the use of two different calibration tables when running with different gases. One of two methods can be used to switch between the two calibration curves:

1) Use of Contact Input:

When the contact input is programmed for curve switching, an open contact will select curve #1 and a contact closure will select curve #2.

2) Use of the Keypad:

If the contact input is not programmed for curve switching, pressing F2 and F3 simultaneously will prompt an operator to manually switch curve upon entering a password and confirming the action by pressing the appropriate key.

Pressing F2 & F3 simultaneously:

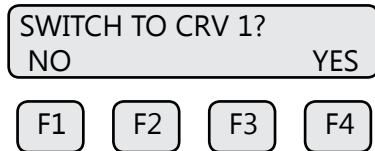

Password needs to be entered if active (default: 1234):

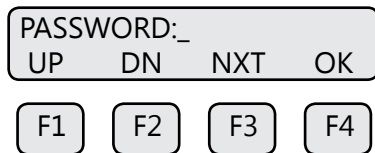

After entering a valid password, a brief confirmation message will be displayed for 1 second:

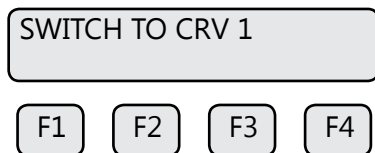

Appendices

3) Programming Contact Input for Curve Switching:

Enter the menu using steps outlined in "Contact Input Settings" section (p. 35) and select "Switch CRV". Please note that the flow meter needs to be programmed for 2 gas curves at the Fox factory before you can select this function. Flow meters are shipped with pre-programmed user requested settings.

INP=SWITCH CRV
NXT OK

F1 F2 F3 F4

Selections are: "Not used"
"Tot Reset"
"Switch Crv"



Helpful Hint:
From normal display mode, press F4 to view the current gas curve selection.

4) Programming Densities for Curve 1 and Curve 2:

When the selected flow unit is mass/time, two different densities will be used for each curve if the meter has been programmed for 2 gas curves. To change the densities:

Go to the unit menu following "Unit Settings" section.

DNS1 = 0.9876
CHG OK

F1 F2 F3 F4

DNS1 is the density associated with curve 1. Change it as needed and press OK.

DNS2 = 1.2876
CHG OK

F1 F2 F3 F4

DNS2 is the density associated with curve 1. Change it as needed and press OK.

Appendices

5) Programming 4-20mA settings for Curve 1 and Curve 2:

When the meter has been programmed for 2 gas curves, 2 sets of 4-20mA settings for flow rate are used. To program these settings:

Go to the 4-20mA setting following the "Analog 4-20mA Settings" section.

20mA = 500SCFM
CHG OK

F1 F2 F3 F4

20mA is the upper limit associated with curve 1. Change it as needed and press OK.

4mA = 0
CHG OK

F1 F2 F3 F4

4mA is the lower limit associated with curve 1. Change it as needed and press OK.

20 maCv2=450 SCFM
CHG OK

F1 F2 F3 F4

20 maCv2 is the upper limit associated with curve 2. Change it as needed and press OK.

4 maCv2=0
CHG OK

F1 F2 F3 F4

4 maCv2 is the lower limit associated with curve 2. Change it as needed and press OK.

Appendices

6) Operation:

To avoid confusion, only one of two techniques is enabled. If the contact input is assigned to switch gas curves, then the ability to switch using the F2 and F3 function keys on the front panel is disabled.

Two totalizers (Total 1 and Total 2) and two elapsed time counters are available on the display and through the USB serial communication. The reset function will reset all totalizers and elapsed time counter to zero.

In the event of a power failure, the software will remember the last curve in use. Upon powering up again, the FT3 unit will continue to use that curve.

Switching between gas curves will require a password unless the password is set to "0", which disables it.

The calibration certificates for order with 2 gas curves will identify which gas is Gas 1 and Gas 2.

When measuring in mass units, a density value must be entered for each gas curve.

Appendices

Tilt Installations

These variations on installations help prevent moisture and condensation from forming on the sensor and disrupting accurate flow measurement. Fox Thermal recommends 180° installation, if possible.

Tilt installation at 90°, CW

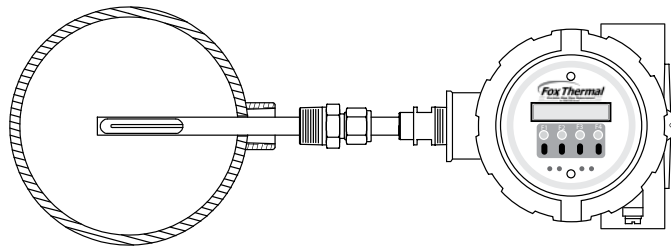

Tilt Installation at 90°, CCW

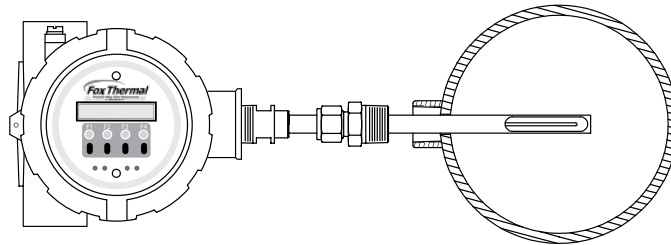

Tilt Installation at 180°

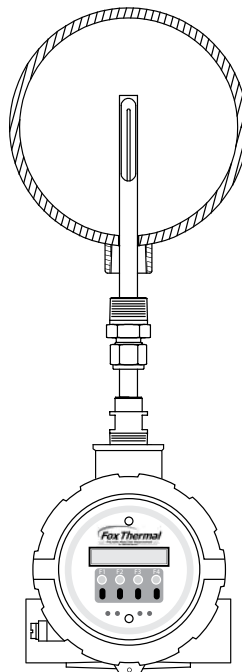

Appendices

Tilt Installation at 45°

When restricted physical installation space exists, the FT3 can also be installed at a 45° angle. Please note that the display's orientation will remain aligned with the top of the meter.



NOTE! Displays are rotatable only in 90° angle increments.

For more information about display configurations, visit www.foxthermal.com to view other display configurations.

Tilt Installation at 45°, CW

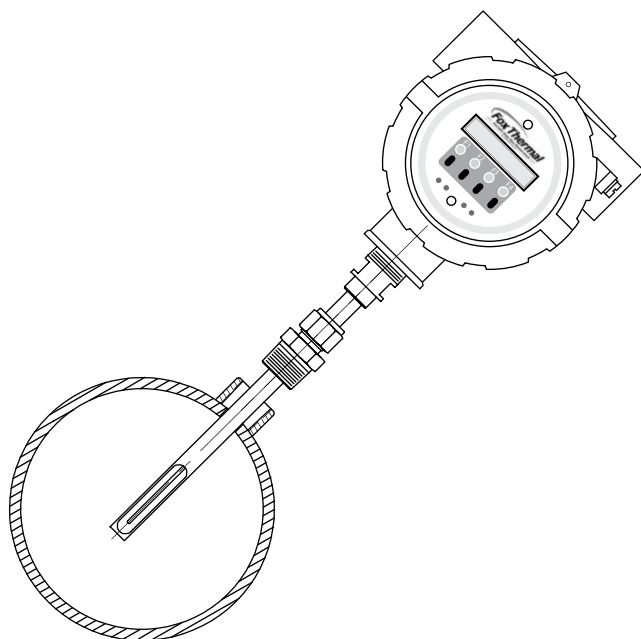

Returning a Meter

Returning a Meter

The Fox Thermal Customer Service Department (PH: 831- 384-4300 or FAX: 831-337-5787) can help you through the process of returning a meter for service.

If it becomes necessary to return a Fox Thermal flow meter for service or recalibration, please follow these steps:

A Return Material Authorization (RMA) Number must be obtained from the Fox Thermal Customer Service Department prior to returning any Fox Thermal meter(s).

- Please have your meter's serial number(s) available.
- Read and complete the Fox Thermal RMA Customer Information Form. Be sure to initial the decontamination statement as well as provide complete return shipping instructions (we cannot deliver to post office boxes).
- The entire flow meter must be returned, including all electronics (unless specifically instructed to do otherwise). ALL serial numbers must match their corresponding meters. This is especially necessary when returning remote and/or flow body models.
- Clean and decontaminate all wetted parts before returning to Fox Thermal.
- Ship the meter to the following address:

Fox Thermal Instruments, Inc.
399 Reservation Road
Marina, CA 93933
Attn: Service Dept.
[RMA Number]



NOTE! Be sure to review all of the information on the Customer Information Form before sending your meter to the Fox Thermal Customer Service Department. The Fox Thermal Shipping/Receiving Department cannot accept meters that have not been prepared appropriately.

What to expect while your meter is being serviced

Depending on the type of service required when returning your Fox Thermal meter, there are varying turnover times for servicing a meter. The average time needed to service the meter is 7-10 days (not including shipping or peak production times).

If you have already shipped your meter to Fox Thermal for servicing and would like to check the status of your meter, please fill out our online Service Order Status form located at www.foxthermal.com and you will hear from a Customer Service Rep within 1 business day of your requested update.

Rush recalibration service is available for a fee. Restrictions apply.

Warranty

Warranty

(a) Fox Thermal Instruments, Inc. (Fox Thermal) warrants that the products furnished under this Agreement will be free from defects in material and workmanship for a period of one year from the date of shipment. The customer shall provide notice of any defect to Fox Thermal, within one week after the Customer's discovery of such defect. The sole obligation and liability of Fox Thermal, under this warranty shall be repair or replace, at its option, without cost to the Customer, the defective product or part.

(b) Upon request by Fox Thermal, the product or part claimed to be defective shall immediately be returned at the Customer's expense to Fox Thermal. Replaced or repaired products or parts will be shipped to the Customer at the expense of Fox Thermal. Fox Thermal shall have the right of final determination as to the existence and cause of defect.

(c) There shall be no warranty or liability for any products or parts that have been subject to misuse, accident, negligence, failure of electric power or modifications by the Customer without the written approval of Fox Thermal. Final determination of warranty eligibility shall be made by Fox Thermal. If a warranty claim is considered invalid for any reason, the Customer will be charged for services performed and expenses incurred by Fox Thermal, in handling and shipping the returned unit.

(d) The liability of Fox Thermal shall be limited to replacing or repairing, at its option, any defective parts which are returned. Labor and related expenses incurred to install replacement parts are not covered by this warranty.

(e) As to replacement parts supplied or repairs made during the original warranty period, the warranty period for the replacement or repaired part shall terminate with the termination of the warranty period of the original product or part.

(f) The use of these products is under exclusive control of the purchaser and Fox Thermal specifically denies any responsibility for the calibration of units and/or accuracy of work performed or the safety of the system in which Fox Thermal products is used. EXTERNAL SAFETY DEVICES MUST BE USED WITH THIS EQUIPMENT.

(g) No warranty is made with respect to custom equipment or products produced to Buyer's specifications except as specifically stated in writing by Fox Thermal and contained in the agreement.

(h) THE FOREGOING WARRANTY CONSTITUTES THE SOLE LIABILITY OF FOX THERMAL, AND THE CUSTOMER'S SOLE REMEDY WITH RESPECT TO THE PRODUCTS AND IS IN LIEU OF ALL OTHER WARRANTIES, INCLUDING ANY WARRANTY OF MERCHANTABILITY OR FITNESS FOR A PARTICULAR PURPOSE, LIABILITIES, AND REMEDIES. EXCEPT AS THUS PROVIDED, FOX THERMAL, DISCLAIMS ALL WARRANTIES, EXPRESS OR IMPLIED, INCLUDING ANY WARRANTY OF MERCHANTABILITY OR FITNESS FOR A PARTICULAR PURPOSE.

Glossary of Terms and Definitions

AC	Alternating Current
AWG	American Wire Gauge
Bara	Bar absolute
CTC	Contact
CAL	Calibration
CHG	Change
COM	Communication
CSV	Current Sense Voltage
DC	Direct Current
DN	Down
DSP	Display
ELP	Elapsed time
Feq	Frequency
Ft^2	Square Feet
I/O	Input/Output
INP	Input
IR	Infrared (IR Buttons = optical switches)
LB	Pound
LB/D	Pound per Day
LB/H	Pound per Hour
LB/M	Pound per Minute
LB/S	Pound per Second
LCD	Liquid Crystal Display
KG	Kilogram
KG/H	Kilogram per Hour
KG/M	Kilogram per Minute
KG/S	Kilogram per Second
M^2	Square Meter
mmHG	Pressure in millimeters of mercury
MMSCFD	Million Standard Cubic Feet per Day
MXFLO	Maximum Flow
NEMA	National Electrical Manufactures Association
NIST	National Institute of Standards and Technology
NLP	Normal Liter
NLPH	Normal Liter per Hour
NLPM	Normal Liter per Minute
NM3	Normal cubic Meter

Definitions

NM3/H	Normal cubic Meter per Hour
NM3/M	Normal cubic Meter per Minute
NPT	National Pipe Thread
UNT	Unit
U/P	Unit per Pulse
PC	Personal Computer
P/U	Pulse per Unit
PIP A ²	Pipe Area
PLC	Programmable Logic Controller
PRM	Parameters
PRS	Pressure
PSIA	Pounds per Square Inch Absolute
Pt	Point
PSW	Password
SIM	Simulation
SCF	Standard Cubic Feet
SCFM	Standard Cubic Feet per Minute
SCFH	Standard Cubic Feet per Hour
SCFD	Standard Cubic Feet per Day
SPC	Special Control
STP	Standard Temperature and Pressure
TMP	Temperature
TSI	Internal Variable
TSV	Internal Variable
420	4-20mA output

Index

Index

- Access to Electronics, p. 14
- Alarm Codes, p. 68
- Alarm wiring, p. 21
- Analog 4-20mA outputs, p. 30
- Breakage or Damage of Probe, p. 62
- CAL-V™
 - Introduction, p. 4
 - Running CAL-V™, p. 48
- Calibration Parameters, p. 44
- Dimension Details,
 - Local Inline Flange, p. 76
 - Local Inline NPT, p. 74
 - Local Insertion, p. 72
 - Local with Retractor, p. 70
 - Remote Insertion, p. 73
 - Remote Inline NPT, p. 75
 - Remote Inline Flange, p. 77
 - Remote with Retractor, p. 71
- Contact I/O, p. 5, p. 34, p. 35
- Contact input settings, p. 35
- Display Screens, p. 27
- Display Setup, p. 36
- Enabling infrared (IR) buttons, p. 50
- Engineering Screens, p. 28
- Entering the programming mode, p. 29
- Equal length sensors, p. 10
- Filter value, p. 42
- Flow Meter Placement,
 - Inline, p. 12
 - Insertion, p. 8
- Flow Units, p. 38
- Frequency / Alarm Output Wiring, p. 21
- Frequency Output, p. 32
- Fuse Replacement, p. 62
- Glossary, p. 90
- Infrared Buttons, p. 52
- Input wiring - General, p. 16
- Installation,
 - Compression Fitting - Insertion, p. 11
 - Compression Fitting - Inline, p. 13
 - General Precautions, p. 8
 - Lateral Placement - Inline, p. 12
 - Lateral Placement - Insertion, p. 8
 - Mounting - Insertion, p. 8
 - Mounting - Inline, p. 12
 - Orientation of Meter - Inline, p. 13
 - Orientation of Meter - Insertion, p. 10
- Introduction, p. 4
- IR Buttons, p. 5
- Level 2 password, p. 37
- Local Display,
- Mass Flow, p. 4
- Measurement Mode, p. 26
- Menu Tree,
 - Digital Output, p. 55
 - Display Menu, p. 58
 - Engineering Display, p. 28
 - Main Menu, p. 54
 - Parameter Menu 1, p. 56
 - Parameter Menu 2, p. 57
- Mounting – Flow Body type, p. 12
- Mounting – Insertion type, p. 8
- Orientation of meter - Inline type, p. 13
- Orientation of meter - Insertion type, p. 10
- Password
 - Level 1, p. 37
 - Level 2, p. 37
 - Programming, p. 38
- Power Input Wiring, p. 16
- Preventative Maintenance, p. 62
- Product Description, p. 4
- Programming
 - Analog 4-20mA Output, p. 30
 - Alarm Output, p. 34
 - Calibration Parameters, p. 44
 - CAL-V™ verify, p. 48

Index

- Programming (cont'd)
 - Changing values or strings, p. 29
 - Contact Input, p. 35
 - Display Setup, p. 36
 - Filter value, p. 42
 - Flow cutoff, p. 41
 - Flow Parameters, p. 41
 - Flow and maximum frequency, p. 33
 - High Alarm Limit value, p. 43
 - Frequency Output, p. 32
 - Infrared (IR) buttons, p. 52
 - Low Alarm Limit value, p. 43
 - Password, p. 38
 - Pipe Area, p. 42
 - Programming Mode, p. 29
 - Pulse-per-unit, p. 32
 - Reset Total & Elapsed Time, p. 45
 - Restore Database, p. 45
 - Reset CRC, p. 46
 - Selecting from a list, p. 29
 - Serial Communication, p. 35
 - Simulation, p. 46
 - Unit-per-pulse, p. 33
 - Unit settings, p. 38
 - Using the Local Display, p. 29
- Remote Wiring Installation, p. 24
- Replacements Fuses, p. 62
- Reset Total and Elapsed Time, p. 45
- Restore Database, p. 45
- Return Procedure, p. 88
- Scope, p. 7
- Sensor Cleaning, p. 62
- Sensor Orientation,
 - Inline,
 - Insertion,
- Signal wiring, p. 14
- Simulation Mode, p. 46
- Theory of Operation, p. 4
- To program the display, p. 36
- Totalizer Rollover, p. 45
- Troubleshooting, p. 63
 - Alarm Codes, p. 68
 - Installation Problems, p. 66
- Unequal length sensors, p. 11
- USB Interface, p. 26
- Warranty, p. 89
- Wiring
 - Alarms, p. 21
 - Frequency/Alarm Outputs, p. 21
 - Grounding, p. 14
 - Input - Remote, p. 24
 - Instructions, p. 14
 - Power Input, p. 16
 - Precautions, p. 14
 - Remote meters, p. 24
 - Sensor, p. 24
- Zero CAL-CHECK®
 - Introduction, p. 4
 - Running Zero CAL-CHECK®, p. 50



Wiring



Definition of Terms



Troubleshooting Tips



NOTE! is used for Notes and Information



WARNING! is used to indicate a hazardous situation which, if not avoided, could result in death or serious injury.



CAUTION! is used to indicate a hazardous situation which, if not avoided, could result in minor or moderate injury.



Indicates compliance with the WEEE Directive. Please dispose of the product in accordance with local regulations and conventions.



Indicates compliance with the applicable European Union Directives for Safety LVD (Low Voltage Directive 2006/95/EC), EMC (Electromagnetic Compatibility Directive 2004/108/EC), and PED (Pressure Equipment Directive 97/23/EC).

IP67

Enclosure Protection Classification per IEC 60529: Protected against the ingress of dust and Immersion.