



Catalog | November 2013

Low voltage Roller table motors

We provide motors, generators and mechanical power transmission products, services and expertise to save energy and improve customers' processes over the total life cycle of our products, and beyond.



Low voltage Roller table motors

Sizes 180 to 450

Roller table drives	4
Frequency converters	4
Roller table motors	7
Rating plates	12
Ordering information	13
Technical data	14
Variant codes	16
Dimension drawings	17
Motor construction	18
Roller table motors in brief	20



Roller table drives

Roller tables incorporate a number of motors, the speed of which can be steplessly controlled by one or more frequency converters.

The rolling mill environment places severe stress on roller table drives. As plates and billets travel along the roller table at high speeds, the motors driving the rollers are subjected to high torque loads. At the same time, the reliability of the drive system is constantly threatened by the high ambient temperature, humidity, and the risk that fine dust particles from the process could infiltrate the motors.

To meet these rigorous demands, ABB has developed its Roller Table AC Drive System, which comprises the new, robust M3RP induction motors, together with ABB frequency converters.

The totally enclosed construction of the M3RP induction motors renders them immune to the ingress of moisture and dust. The power factor of ABB frequency converters with IGBT supply units is 1.0 under any load conditions. Together the motor and frequency converter provide a competitive solution, with high availability and minimal maintenance costs.

Frequency converters

A single AC drive system typically consists of an input transformer or an electric supply, frequency converter, AC motor, and load machine. The single frequency converter consists of a rectifier, DC link and inverter.

In a multidrive system there is a common rectifier unit, and the inverters are directly connected to a common DC link. There can be dozens of inverters connected to the common DC link, and the dimensioning of the rectifier unit is based on the simultaneous power requirement from the network.

Figure 1. A single frequency converter consists of 1) rectifier, 2) DC link, 3) inverter unit, and 4) electric supply.

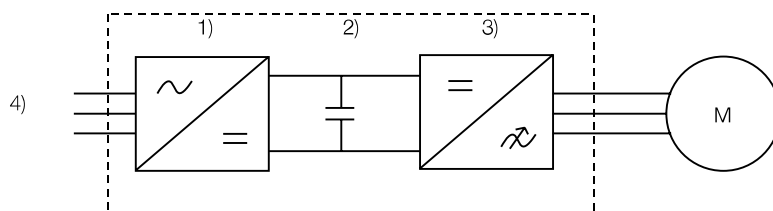
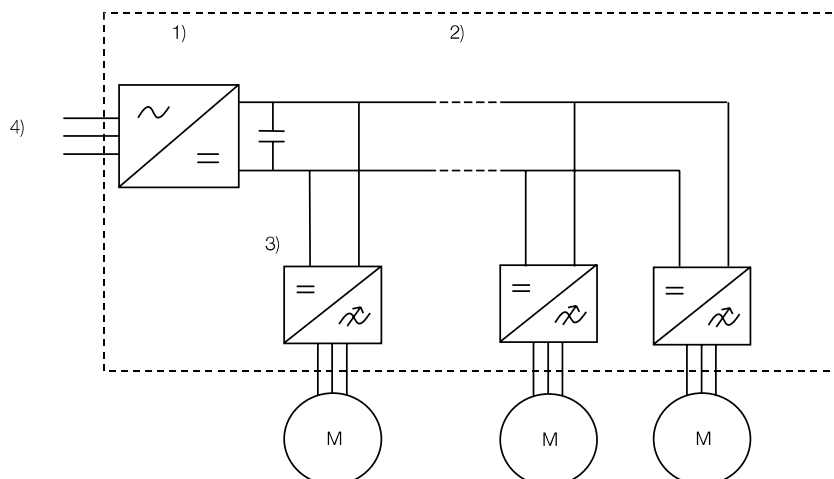

Figure 2. A Multidrive system, which has 1) separate supply section, 2) common DC bus, 3) drive sections, and 4) electric supply (normally from transformer).



The rectifier converts the mains supply voltage to a constant intermediate DC voltage, which is then inverted back to AC voltage by the inverter.

ABB frequency converters feature Direct Torque Control (DTC), a technology developed by ABB. DTC employs advanced motor theory to calculate the motor torque directly, without modulation and feedback - i.e. no pulse encoder is required. The controlling variables are motor magnetizing

flux and motor torque. This technique is so effective that the torque response of DTC controlled drives is typically faster than that of any other industrial drives. At the same time DTC achieves dynamic speed accuracy better than any open loop AC drive, and comparable to DC drives using feedback. This excellent control performance without the use of pulse encoders is very important for roller table applications.

Common DC bus of ACS800 multidrives

Figure 3. Principle diagram for a common DC bus.

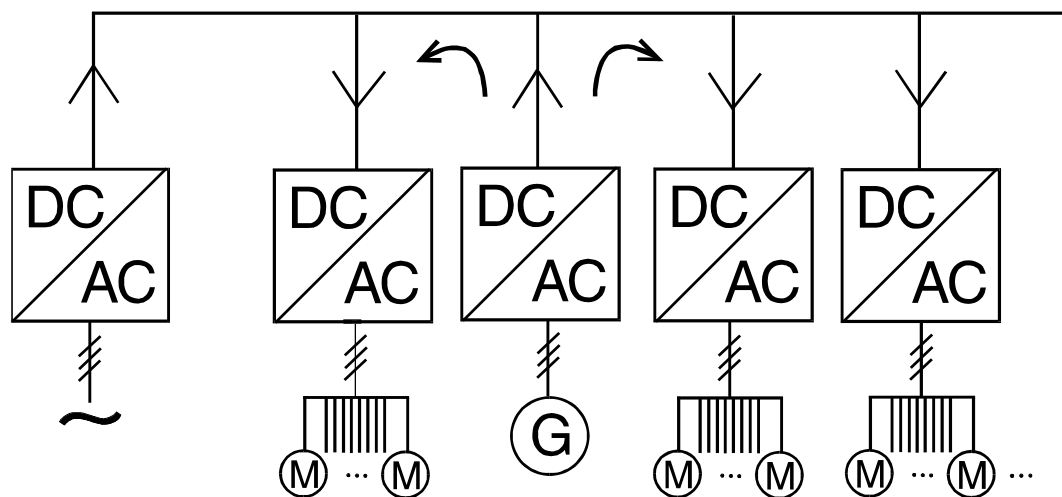

ACS800 multidrives are based on a common DC bus arrangement, with a single power entry and common braking resources for several drives. There are a number of alternatives on the supply side, ranging from simple diode supply units up to highly sophisticated IGBT supply units. The construction of a multidrive simplifies the total installation and provides many advantages.

In multimotor applications, the common DC bus and single power line connection for a number of drives represents a

very efficient solution when compared with separate, single small converters. Each inverter is connected to the DC bus and the motors are connected to the inverter outputs. All the inverters are capable of 4-quadrant operation. When an inverter is used to brake a motor, the energy from the (regenerative) braking operation is sent back to the DC bus and can be used by other motoring sections. This ability to recirculate power produces substantial energy savings.

Benefits of ABB's multidrives frequency converter

- reduced line currents and simple braking arrangements
- energy circulation over the common DC busbar, which can be used for motor-to-motor braking without the need of for a braking chopper or regenerative supply unit
- reduced component count and increased reliability when a common supply and DC link are used
- reduced cabling due to the single power entry for several drives
- savings in cabling, installation and maintenance costs (the supply and inverter modules, for example, are fitted with plug connections for fast and easy module changing)
- space savings through modular construction (space savings up to 60 % compared to the previous generation of ABB multidrives)
- overall safety and control functions made possible by the common supply.



Figure 4. ACS800 multidrives cubicles

Regenerative IGBT supply unit

An ACS800 multidrive equipped with an IGBT supply unit (ISU) has a fundamental power factor of 1.0 under any load conditions. This means that the converter takes only active power from the mains – i.e. supplementary tariffs for reactive power consumption do not need to be paid. By comparison, a thyristor supply has a power factor between 0.97 and 0.99 in motoring mode and 0.88 or higher in regenerative mode.

The unity power factor of ACS800 multidrives with IGBT supply unit means that there is no need to purchase power factor correction equipment. Low reactive power consumption also means that smaller cables and lower rated transformers can be used.

The total current distortion (THDI) of the IGBT supply unit is less than 5 %, which is much less than with a 12-pulse converter.

The IGBT supply provides a constant DC voltage which is very stable even if there are variations in the supply voltage or load. The constant DC voltage guarantees stable process conditions, which is a very important factor in constant torque applications. By contrast, the DC voltage from a thyristor supply, for example, varies according to the supply voltage and load.

An IGBT supply and constant DC voltage ensure the full nominal voltage is available to the motor. With other types of rectifier, which cannot maintain a constant DC voltage, the motor has to be over-dimensioned to allow for the lower output voltage.

A regenerative supply enables the roller table motors to quickly reverse direction. This is essential to accommodate the reversing duty cycle of the table, which involves repetitive motor braking. Regenerative braking of the whole system may also be needed during controlled or emergency stops.

Built-in redundancy

The inverter section of ACS800 multidrives consists of three-phase modules. The modules – each of which is a complete three-phase inverter – are connected in parallel according to the motor power requirement. Parallel connection of the modules provides built-in redundancy, enabling the system

to run with a partial load if one module fails. It also makes for higher drive availability and greater process uptime. These three-phase inverter modules are unique to ABB's ACS800 multidrives, and have not been available in previous generations of ABB drives.

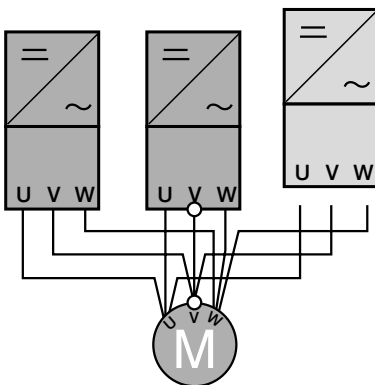

Figure 5. Parallel connected modules



Constant torque

Roller tables represent a typical constant torque application. In this type of application the line current is directly proportional to the motor power consumed, meaning it is small at low speed (see figure).

Rectifier dimensioning: In multidrives systems with a common DC bus, motoring and generating power can occur at same time. The following formula gives an approximate calculation of rectifier power:

$$S_{\text{rectifier}} = SP_{\text{motoring}} / 0,96 - SP_{\text{generating}} \times 0,96$$

All-round optimum solution

When selecting the right drive solution for roller tables, it is important to take into consideration not only the direct investment costs but also the operating costs. Multidrives deliver savings in investment costs, as it reduces cable work by eliminating the need for supply cabling to individual converters. In addition, the multidrive with its common supply section and compact modular construction helps to save space – a significant factor as space in the electrical room is often limited.

ABB drives with their direct torque control (DTC) feature excellent dynamic performance, which is essential for roller

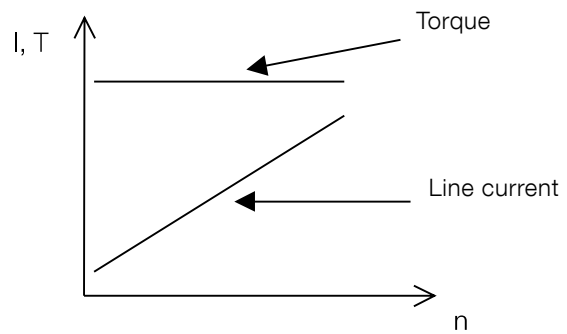

Figure 6. Line current in a constant torque application.

table applications. Even without a tachometer, DTC delivers good motor speed accuracy, superb torque control and full torque at zero speed; this results in less stress on machinery, less process downtime and lower investment costs. Finally, the low harmonics and unity power factor of the regenerative IGBT supply unit enable fast reversing of the roller table and produce savings in operating costs.

For more information on frequency converters, see web site www.abb.com/motors&drives.

Roller table motors

General

The roller table motors supplied by ABB are squirrel cage motors which are specially designed for use with frequency converters. Robust in construction, the motors are fully sealed to withstand the tough conditions in rolling mills.

The motors are low speed units intended for direct connection to rollers. The pole number and frequency can be selected, avoiding the need for gearboxes and therefore saving on maintenance costs and increasing the overall efficiency of the drive.

Mechanical design

The motors feature a number of mechanical solutions that have been designed for the extreme conditions found in rolling mills.

The standard shaft end is of cylindrical construction. Conical shaft ends, as well as double shaft extensions, are available on request.

Robust, die-cast aluminum squirrel cage rotors, which are highly wear-resistant, are used throughout the motor range. The rotor slot design is optimized for frequency converter applications.

Drain holes

All motors are provided with drain holes and plugs which, depending on the motor's mounting position, are located at the lowest point. The plugs are in the open position when the motors are delivered.

Assembly dimensions and shaft heights are in accordance with IEC 60072-1. The normal motor mounting position is B3/IM1001. Flange mounting (IM B5/IM3001) is possible for frame sizes 180 to 250 on request.

The enclosure of the motors is protected to IP55. Higher degrees of protection, up to IP 65, are also available. If required, the stator frame of M3RP motors can be pressurized with air to prevent any ingress of water or dust. ABB offers roller table motors in sizes 180 to 450, with smaller sizes available on request.

The frames and bearing end shields are made of cast iron. Spheroidal graphite cast iron is used as standard in frame sizes 355-450, and is available on request for smaller frame sizes. All fixing screws and bolts are locked.

The motors are totally enclosed, frame cooled motors, with no external cooling fan, in accordance with IEC 60034-6, IC 410. The stator frames have crosswise vertical cooling ribs, allowing optimum heat flow away from the motor surface. A water-cooled version is available on request.

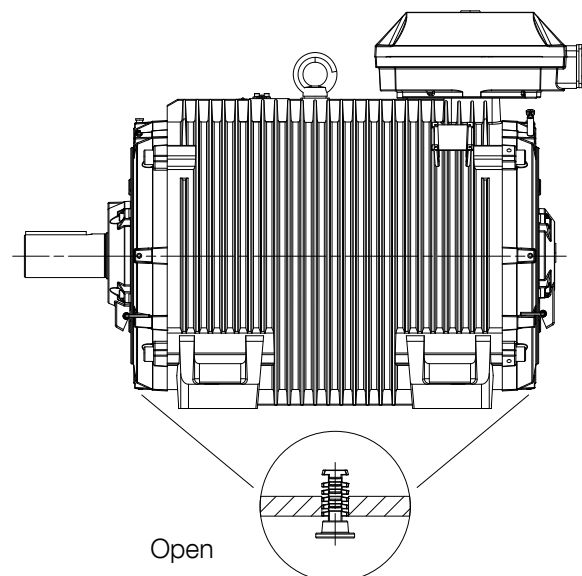

Terminal box

The terminal box is located on the top of the motor at the N-end. In frame sizes 180 to 250 the terminal box is integrated with the stator frame. In larger motors the terminal box can be rotated 4 x 90°, with the cable direction from the N-end as standard. Terminal boxes positioned either on the left or right side of the motor are available on request.

Co-ordination of terminal boxes and cable entries

If no ordering information on the cable is given, it is assumed to be PVC-insulated and termination parts are supplied according to the following table.

The terminal board has three terminals for the power leads and one terminal for earthing. All the motors are equipped with an external earthing stud on the motor frame.

The terminal box is normally equipped with cable glands. To get suitable terminations, please state cable type, quantity, cable direction and size when ordering.

Voltage 220 - 690 V

Motor size	Terminal box	Main metric cable entry	Auxiliary cable	Cable gland entries diameter mm	Max. connection cable area, mm ²	Max. rated current A (D/Y conn.)	Terminal bolt size
180		1 x M32 x 1.5	1 x M20 x 1.5	Ø14-21	16	25	M5
200 -250	-	1 x M40 x 1.5	1 x M20 x 1.5	Ø18-27	35	63	M6
280-315	-	1 x M50 x 1.5	2 x M20 x 1.5	Ø26-35	1 x 150	210	M12
355-400	-	1 x M63 x 1.5	2 x M20 x 1.5	Ø32-49	1 x 240	370	M12
450	-	2 x M63 x 1.5	2 x M20 x 1.5	Ø32-49	2 x 240	750	M12

Dimensions of terminal boxes

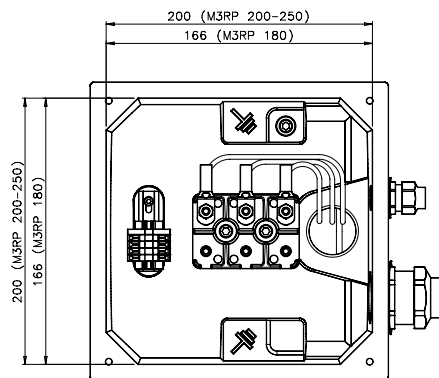

Terminal box M3RP 180 to 250

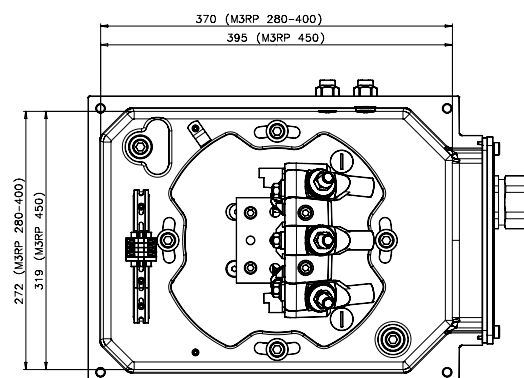

Terminal box M3RP 280 to 450

Bearings

Roller table motors are fitted with 63-series single row deep groove ball bearings. Alternatively, a cylindrical roller bearing can be used at the D-end of the motor, if required.

The bearings are axially spring loaded, thus eliminating the bearing clearance. This improves bearing resistance to vibrations while allowing for normal thermal expansion. The D-end of the motor is equipped with a fixed bearing.

The motors are provided with regreasable bearings.

Motor sizes 315 to 450 have insulated bearings at N-end as standard.

Bearing types

Motor size	D-end Ball bearing	N-end Ball bearing
M3RP 180	6310/C3	6309/C3
M3RP 200	6312/C3	6310/C3
M3RP 225	6313/C3	6312/C3
M3RP 250	6315/C3	6313/C3
M3RP 280	6316/C3	6316/C3

Motor size	D-end Ball bearing	N-end Ball bearing
M3RP 315	6319/C3	6316/C3 VL0241
M3RP 355	6322/C3	6316/C3 VL0241
M3RP 400	6324/C3	6319/C3 VL0241
M3RP 450	6326M/C3	6322/C3 VL0241

Lubrication

Motors are provided with grease nipples so the motor can be lubricated while running. If the bearings cannot be lubricated while running, please follow the procedure as described in the manuals. For slowly rotating and/or highly loaded bearings, lithium complex (EP) greases are recommended.

A lubrication instruction plate is fitted to the motor frame, stating the type of grease and lubrication interval. The D-end bearing must be lubricated so that grease comes out of labyrinth channels and completely replaces the old grease.

Lubrication intervals

ABB follows the L_1 -principle in defining lubrication interval. That means that 99 % of the motors make the interval time. The lubrication intervals can also be calculated according to the L_{10} -principle, which usually doubles the values calculated according to the L_1 principle. Values available from ABB at request.

The table below gives lubrication intervals according to the L_1 -principle for different speeds. The L_{10} values are valid for horizontally mounted motors (B3), with about 80 °C bearing temperature and high quality grease with lithium complex soap and mineral or PAO-oil.

For more information, see ABB's low voltage motors manuals.

Lubrication intervals in duty hours

Motor size	Bearing	1000 r/min	750 r/min	250-500 r/min	≤ 250 r/min
180	6310	4800	5500	6500	8100
200	6312	4300	5000	6100	7700
225	6313	4000	4800	5800	7500
250	6315	3600	4400	5400	7100
280	6316	3400	4200	5200	7000
315	6319	2900	3700	4700	6500
355	6322	2400	3100	4200	6000
400	6324	2100	2800	3900	5700
450	6326	1900	2600	3700	5500

Bearing seals

Roller table motors are equipped with labyrinth sealing at D-end. N-end is totally enclosed. This construction gives a proper protection in demanding environment against water and dust.

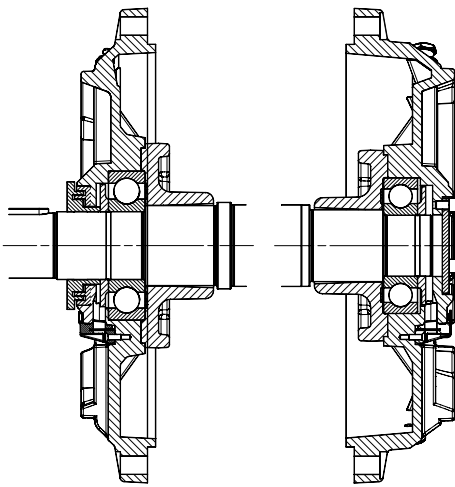

Motor sizes 180 to 250

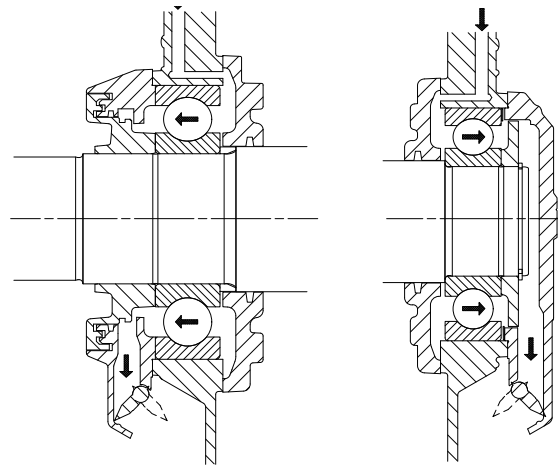

Motor sizes 280 to 450

Stator winding

The stator winding is designed for use with frequency converters in the rolling mill environment. The motors are electrically designed for a certain speed range in order to minimize the current and enable use of the smallest possible frequency converter.

Roller table motors typically run at low speeds and have high peak torque demands, but the requirements vary case by case.

The high number of poles (6 to 12) means the stator winding is extremely strong and mechanically resistant because the winding ends are very short and tightly terminated.

The stator winding insulation meets Class F requirements (temperature limit +155 °C). Class H insulation (temperature limit 180 °C) is available on request.

The stators are wound with Class H enamel wire and the winding is then trickle impregnated with polyester or epoxy resin. Gaps between individual conductors are effectively filled with the impregnated material resulting in good thermal conductivity and superior mechanical strength.

An effective way of protecting the stator winding against overheating is direct monitoring of the winding temperature. As a standard feature the motors are fitted with three PTC thermistors embedded in the stator winding overhang. Six thermistors (for warning and tripping), bimetallic relays or Pt-100 measuring resistors are also available on request.

Rating plates

CE						
3 ~ Motor M3RP 450LB 8 IM1003						
618694-10			2013		No. 3GF13101106	
				Ins.cl. F		IP 55
V	Hz	kW	r/min	A	cos φ	Duty
440 D	11.3	62	166	115	0.76	S9
Prod. code 3GRP454520-AXG incl. variants						
			Nmax		r/min	
6326M/C3			6322/C3VLO241		3650 kg	
ABB IEC 60034-1						

Main rating plate

ABB	
Bearings	
6326M/C3	6322/C3VLO241
Regreasing amount	
140 g	120 g
Valid with following ambient temperature and running speed.	
	+40/166 °C/rpm
Regreasing interval	
- in duty hours	5000 h
or	
- minimum every if duty hours not reached	12 months
Grease	ESSO UNIREX EP2
See respective "Motor Manual"	
3GZF194730-750	

Lubrication plate

Ordering information

When placing an order, please state the following minimum data in the order, as in the example.

The product code of the motor is composed in accordance with the following example.

Example	
Motor type	M3RP 280 MB
Pole number	6
Mounting arrangement (IM-code)	IM B3 (IM 1001)
Rated output	22 kW
Product code	3GRP283-ADG
Variant codes if needed	

Explanation of the product code

Motor type	Motor size	Product code	Mounting arrangement code, Voltage and frequency code, Generation code	Variant codes
M3RP	280MB	3GRP 283 320	- ADG	003 etc.
		1 2 3 4 5 6 7 8 9 10	11 12 13 14	

Positions 1 to 4

3GRP Totally enclosed fan cooled motor with cast iron frame squirrel cage

Positions 5 and 6

IEC-frame

18	180
20	200
22	225
25	250
28	380
31	315
40	400
45	450

Position 7

Speed (Pole pairs)

3	6 poles
4	8 poles
5	10 poles
6	12 poles

Position 8 to 10

Serial number

Position 11

- (dash)

Position 12

Mounting arrangement

A	Foot-mounted, top-mounted terminal box
B	Flange-mounted, large flange
H	Foot- and flange-mounted, terminal box top-mounted

Position 13

Voltage and frequency code

See table below

Position 14

Generation code

A, B, C...

The product code must be, if needed, followed by variant codes.

Code letters for supplementing the product code - single speed motors

Code letter for voltage

Motor size	A	S	B	D	H	E	T	U	X
160-450	220 V	230 V	380 V	400 V	415 V	500 V	660 V	690 V	Other rated voltage, connection or frequency, 690 V maximum

Technical data

Roller table motors, 1000 - 750 r/min

IP 55 – IC 411 – Insulation class F, temperature rise class B

Output				Torque			Current			Power factor			Inertia		
				Speed	T_{rms}	T_{max}	T_{acc}	I_0	I_n	I_{acc}	$\cos \varphi_0$	$\cos \varphi_n$	$\cos \varphi_{acc}$	J_{rt}	Weight
kW	Motor type	Product code		r/min	Nm	Nm	Nm	A	A	A				kg	kg
1000 r/min = 6 poles				400 V 50 Hz											
7	M3RP 180 LB	3GRP 183 520-••G		980	68	225	160	9	15	32	0.06	0.76	0.83	0.25	219
10	M3RP 200 LA	3GRP 203 510-••G		985	96	380	285	6	18	57	0.08	0.88	0.87	0.43	245
11	M3RP 200 LB	3GRP 203 520-••G		987	106	520	390	8	20	78	0.07	0.88	0.87	0.52	270
12.5	M3RP 225 MB	3GRP 223 320-••G		989	120	640	480	10	23	97	0.07	0.86	0.85	0.66	315
15	M3RP 225 MC	3GRP 223 330-••G		990	145	850	635	13	27	136	0.07	0.85	0.83	0.78	340
18	M3RP 250 MB	3GRP 253 320-••G		991	173	1100	825	16	33	164	0.06	0.84	0.85	1.59	455
22	M3RP 280 MB	3GRP 283 320-••G		993	210	1320	990	18	40	195	0.06	0.85	0.84	2.6	620
30	M3RP 280 MC	3GRP 283 330-••G		993	288	1530	1145	20	52	224	0.06	0.88	0.84	3.0	690
37	M3RP 315 LA	3GRP 313 510-••G		994	355	2020	1515	28	65	300	0.05	0.86	0.84	5.1	870
45	M3RP 315 LB	3GRP 313 520-••G		994	430	2630	1970	36	80	380	0.05	0.86	0.84	5.9	950
55	M3RP 315 LC	3GRP 313 530-••G		994	525	3220	2415	42	97	467	0.05	0.86	0.84	6.9	1060
750 r/min = 8 poles				400 V 50 Hz											
5.5	M3RP 180 LB	3GRP 184 520-••G		728	72	216	160	6	12	27	0.08	0.75	0.80	0.25	219
8	M3RP 200 LA	3GRP 204 510-••G		740	103	420	315	8	16	49	0.07	0.82	0.85	0.43	245
9	M3RP 200 LB	3GRP 204 520-••G		740	116	560	420	10	18	66	0.06	0.79	0.84	0.52	270
10	M3RP 225 MB	3GRP 224 320-••G		741	128	610	455	13	21	70	0.06	0.75	0.84	0.66	315
12.5	M3RP 225 MC	3GRP 224 330-••G		742	161	800	600	17	27	93	0.05	0.74	0.83	0.78	340
15	M3RP 250 MB	3GRP 254 320-••G		744	192	1110	830	20	32	128	0.05	0.74	0.83	1.59	455
18	M3RP 280 MB	3GRP 284 320-••G		745	230	1230	920	22	37	138	0.05	0.75	0.83	2.6	620
22	M3RP 280 MC	3GRP 284 330-••G		746	282	1570	1170	28	46	174	0.05	0.75	0.82	3.0	690
30	M3RP 315 LA	3GRP 314 510-••G		746	384	2270	1700	42	64	254	0.04	0.72	0.82	5.1	870
37	M3RP 315 LB	3GRP 314 520-••G		745	470	2540	1900	45	76	283	0.04	0.75	0.82	5.9	950
45	M3RP 315 LC	3GRP 314 530-••G		745	576	3160	2370	55	92	357	0.04	0.75	0.82	6.9	1060

¹⁾ Technical data on request.

The two bullets in the product code indicate the choice of mounting arrangement, voltage and frequency (see the ordering information page).

Technical data

Roller table motors, 345 r/min

IP 55 – IC 411 – Insulation class F, temperature rise class B

Output			Speed	Torque			Current			Power factor			Inertia	
				T_{rms}	T_{max}	T_{acc}	I_0	I_n	I_{acc}	$\cos \varphi_0$	$\cos \varphi_n$	$\cos \varphi_{acc}$	J_r	Weight
kW	Motor type	Product code	r/min	Nm	Nm	Nm	A	A	A				kg	kg
345 r/min = 8 poles			400 V 23 Hz											
3.3	M3RP 200 LA	3GRP 204 510-••G	338	93	420	315	6	8	24	0.08	0.72	0.90	0.43	245
4	M3RP 200 LB	3GRP 204 520-••G	338	113	580	430	7	9	33	0.07	0.72	0.89	0.52	270
4.5	M3RP 200 LC	3GRP 204 530-••G	338	127	630	470	7	10	35	0.07	0.75	0.88	0.58	285
5	M3RP 225 MC	3GRP 224 330-••G	338	141	670	500	8	11	37	0.06	0.72	0.87	0.82	325
6	M3RP 225 MD	3GRP 224 340-••G	339	169	1020	765	12	15	57	0.05	0.64	0.86	0.87	360
11	M3RP 250 MC	3GRP 254 330-••G	339	310	1570	1175	16	24	88	0.05	0.73	0.85	1.67	470
15	M3RP 280 MB	3GRP 284 320-••G	340	421	1920	1440	22	33	107	0.05	0.73	0.84	2.6	620
18.5	M3RP 280 MC	3GRP 284 330-••G	340	520	2490	1865	26	40	137	0.04	0.74	0.83	3.0	690
25	M3RP 315 LA	3GRP 314 510-••G	340	702	3140	2350	33	53	170	0.04	0.75	0.84	5.1	870
30	M3RP 315 LB	3GRP 314 520-••G	340	840	3770	2820	37	62	203	0.04	0.76	0.83	5.9	950
35	M3RP 315 LC	3GRP 314 530-••G	341	980	5490	4115	55	79	299	0.03	0.69	0.82	6.9	1060
40	M3RP 355 SA	3GRP 354 110-••G	342	1110	7320	5485	78	101	402	0.03	0.61	0.79	10	1550
50	M3RP 355 SB	3GRP 354 120-••G	342	1390	8550	6410	86	118	461	0.03	0.65	0.80	12	1750
60	M3RP 355 LA	3GRP 354 510-••G	342	1670	11840	8880	118	153	660	0.03	0.61	0.78	14	2000
85	M3RP 400 MA	3GRP 404 310-••G	343	2360	13600	10200	161	214	701	0.03	0.61	0.81	22	2500
100	M3RP 400 LA	3GRP 404 510-••G	343	2780	16400	12300	193	254	846	0.03	0.6	0.81	26	2850
120	M3RP 450 LA	3GRP 454 510-••G	342	3350	17500	13100	173	265	910	0.03	0.69	0.81	26	3400
132	M3RP 450 LB	3GRP 454 520-••G	342	3686	20000	15000	195	295	1030	0.03	0.68	0.81	29	3650
150	M3RP 450 LC	3GRP 454 530-••G	342	4188	24500	18300	240	345	1260	0.03	0.66	0.81	35	4000
165	M3RP 450 LD	3GRP 454 540-••G	343	4594	30500	22800	285	395	1570	0.03	0.63	0.81	41	4450

¹⁾ Technical data on request.

The two bullets in the product code indicate the choice of mounting arrangement, voltage and frequency (see the ordering information page).

Variant codes

Code ¹⁾ / Variant	Frame size				
	180-250	280	315	355-450	
Bearings and lubrication					
037	Roller bearing at D-end.	P	P	P	P
043	SPM-nipples.	S	S	S	S
Insulation system					
014	Winding insulation class H.	P	P	P	P
405	Special winding insulation for frequency converter supply.	P	P	P	P
Painting					
114	Special paint colour, standard grade.	P	P	P	P
179	Special paint specification.	R	R	R	R
Protection					
158	Degree of protection IP65.	P	P	P	P
250	Degree of protection IP66.	P	P	P	P
403	Degree of protection IP56.	P	P	P	P
Rating plates					
209	Non-standard voltage of frequency.	P	P	P	P
Shaft & rotor					
070	One or two special shaft extensions, standard shaft material.	P	P	P	P
Stator winding temperature sensors					
122	Bimetal detectors, break type (NCC), (3 in series), 150°C, in stator winding.	P	P	P	P
436	PTC-thermistors (3 in series), 150°C, in stator winding.	S	S	S	S
441	PTC-thermistors (3 in series 130°C & 3 in series 150°C, in stator winding.	P	P	P	P
445	Pt100 (1per phase) in stator winding.	P	P	P	P
Terminal box					
418	Separate terminal box for temperature detectors.	P	P	P	P
Testing					
149	Test according to separate test specification.	R	R	R	R
Variable speed drives					
701	Insulated bearing at N-end.	P	P	S	S
472	1024 pulse tacho (L&L 861).	P	P	P	P
473	2048 pulse tacho (L&L 861).	P	P	P	P

¹⁾ Certain variant codes cannot be used simultaneously.

- S = Included as standard
- P = New manufacture only.
- M = On modification of a stocked motor, or on new manufacture, the number per order may be limited.
- R = On request.
- NA = Not applicable

Dimension drawings

Roller table motors, sizes 180 - 250

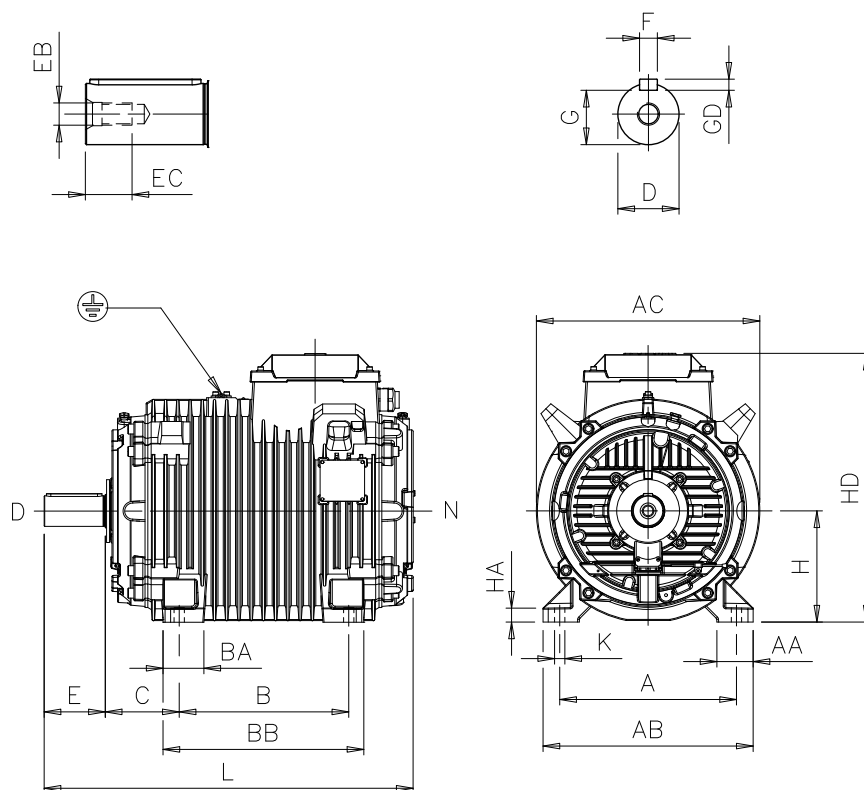

Foot-mounted; IM B3 (IM 1001)

Motor size	A	AA	AB	AC	B	BA	BB	C	D	E	EB	EC
180	279	60	325	350	279	55	335	121	48	110	M16	36
200	318	65	378	405	305	75	364	133	55	110	M20	40
225	356	80	425	450	311	100	390	149	60	140	M20	40
250	406	80	473	500	349	120	450	168	65	140	M20	40

Motor size	F	G	GD	H	HA	HD	K	L	L'
180	14	42.5	9	180	25	450	14.5	630	-
200	16	49	10	200	25	485	18.5	670	-
225	18	53	11	225	30	530	18.5	765	-
250	18	58	11	250	30	580	24	775	-

Flange-mounted versions for frame sizes 180-250 are also available on request.

Tolerances:

A, B	± 0,8
D,	ISO k6 < Ø 50mm
	ISO m6 > Ø 50mm
F	ISO h9
H	+0 -0,5
C	± 0,8

Dimension drawings

Roller table motors, sizes 280 - 450

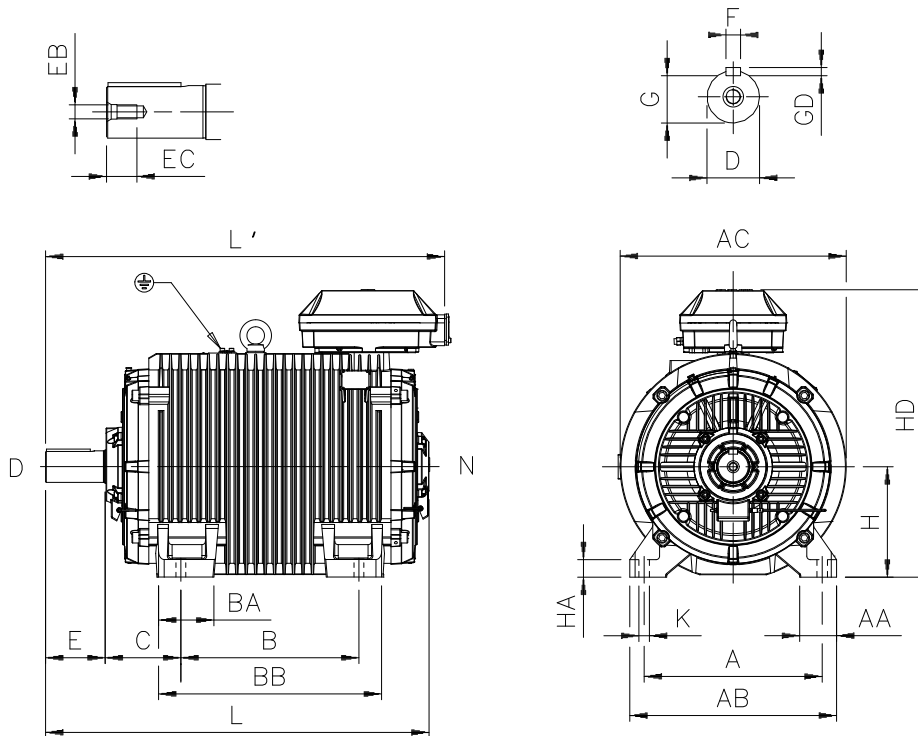

Foot-mounted; IM B3 (IM 1001)

Motor size	A	AA	AB	AC	B	BA	BB	C	D	E	EB	EC
280	457	85	530	580	419	125	550	190	75	140	M20	40
315	508	105	590	655	508	160	640	216	90	170	M24	50
355S	610	120	700	755	500	175	680	254	100	210	M24	50
355L	610	120	700	755	630	175	810	254	100	210	M24	50
400M	686	140	820	835	630	180	800	280	100	210	M24	50
400L	686	140	820	835	710	180	880	280	100	210	M24	50
450	800	160	950	950	1120	215	1320	250	120	210	M24	50

Motor size	F	G	GD	H	HA	HD	K	L	L'
280	20	67.5	12	280	40	750	24	935	995
315	25	81	14	315	50	825	30	1100	1140
355S	28	90	16	355	55	940	35	1225	1280
355L	28	90	16	355	55	940	35	1380	1435
400M	28	90	16	400	60	1025	35	1420	1460
400L	28	90	16	400	60	1025	35	1560	1605
450	32	109	18	450	60	1165	42	1850	1850

Tolerances:

A, B ± 0.8

D_i ISO k6 < Ø 50mm
ISO m6 > Ø 50mm

F ISO h9

H +0 -0.5

C ± 0.8

Roller table motor construction

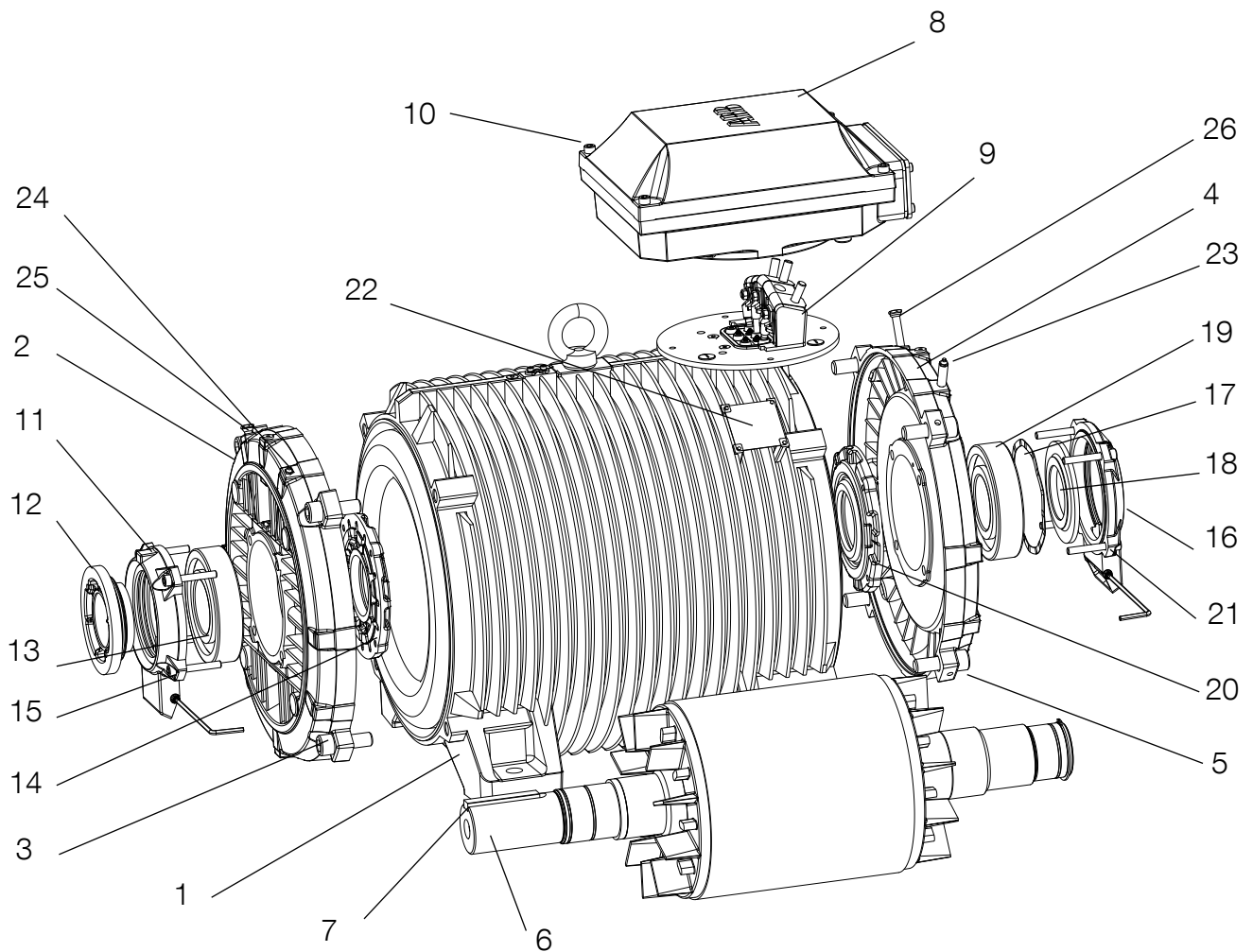

- 1 Stator frame
- 2 Endshield, D-end
- 3 Screws for endshield, D-end
- 4 Endshield, N-end
- 5 Screws for endshield, N-end
- 6 Rotor with shaft
- 7 Key, D-end
- 8 Terminal box
- 9 Terminal board

- 10 Screws for terminal box cover
- 11 Outer bearing cover, D-end
- 12 Valve disc with labyrinth seal, D-end
- 13 Bearing, D-end
- 14 Inner bearing cover, D-end
- 15 Screws for bearing cover, D-end
- 16 Outer bearing cover, N-end
- 17 Wave spring
- 18 Valve disc, N-end

- 19 Bearing, N-end
- 20 Inner bearing cover, N-end
- 21 Screws for bearing cover, N-end
- 22 Rating plate
- 23 Grease nipple, N-end
- 24 Grease nipple, D-end
- 25 SPM nipple, D-end
- 26 SPM nipple, N-end

Roller table motors in brief

Sizes 180 - 250

Motor size		180	200	225	250
Stator and end shields	Material	Cast iron			
	Paint color shade	Munsell blue 8B 4.5/3.25			
	Corrosion class	C3 (medium)			
Feet	Material	Integrated cast iron feet			
Bearings	D-end	6310/C3	6312/C3	6313/C3	6315/C3
	N-end	6309/C3	6310/C3	6312/C3	6313/C3
Axially locked bearings		Locked at D-end			
Bearing seals	D-end	Labyrinth seal			
	N-end	Closed bearing cover			
Lubrication		Regreasable bearings, regreasing nipples M10x1			
Measuring nipples		Included, for condition of the bearings			
Rating plate	Material	Stainless steel			
Terminal box	Frame and cover	Cast iron			
	Corrosion class	C3 (medium)			
	Cover screws	Zinc-electroplated steel			
Connections	Cable entries	1xM32, 1xM20	1xM40, 1xM20		
	Terminals	3 terminals for connection with cable lugs (not included)			
Stator winding	Material	Copper			
	Insulation	Insulation class F			
	Winding protection	3 PTC thermistors, 155 °C			
Rotor winding	Material	Pressure die-cast aluminum			
Balancing method		Half-key balancing			
Keyway		Closed keyway			
Heating elements	Optional	50 W			
Drain holes		Drain holes with closable plastic plugs, open on delivery			
Enclosure		IP 55			
Cooling method		IC 410			

Roller table motors in brief

Sizes 280 - 450

Motor size		280	315	355	400	450
Stator and end shields	Material	Cast iron				
	Paint color shade	Munsell blue 8B 4.5/3.25				
	Corrosion class	C3 (medium)				
Feet	Material	Integrated cast iron feet				
Bearings	D-end	6316/C3	6319/C3	6322/C3	6324/C3	6326M/C3
	N-end	6316/C3	6316/C3 VL0241	6316/C3 VL0241	6319/C3 VL0241	6322/C3 VL0241
Axially locked bearings		Locked at D-end				
Bearing seals	D-end	Labyrinth seal				
	N-end	Closed bearing cover				
Lubrication		Regreasable bearings, regreasing nipples M10x1				
Measuring nipples		Included, for condition of the bearings				
Rating plate	Material	Stainless steel				
Terminal box	Frame and cover	Cast iron				
	Corrosion class	C3 (medium)				
	Cover screws	Zinc-electroplated steel				
Connections	Cable entries	1xM50, 2xM20		1xM63, 2xM20		2xM63, 2xM20
	Terminals	3 terminals for connection with cable lugs (not included)				
Stator winding	Material	Copper				
	Insulation	Insulation class F				
	Winding protection	3 PTC thermistors, 155 °C				
Rotor winding	Material	Pressure die-cast aluminum				
Balancing method		Half-key balancing				
Keyway		Closed keyway	Open keyway			
Heating elements	Optional	50 W	2 x 50 W		2 x 65 W	
Drain holes		Drain holes with closable plastic plugs, open on delivery				
Enclosure		IP 55				
Cooling method		IC 410				

Total product offer

Motors, generators and mechanical power transmission products with a complete portfolio of services



ABB is the leading manufacturer of low, medium and high voltage motors and generators, mechanical power transmission products with an offering of a complete portfolio of services. Our in-depth knowledge of virtually every type of industrial processing ensures we always specify the best solution for your needs.

Low and high voltage IEC induction motors

- Process performance motors
- General performance motors
- High voltage cast iron motors
- Induction modular motors
- Slip-ring modular motors
- Synchronous reluctance motors

Low and medium voltage NEMA motors

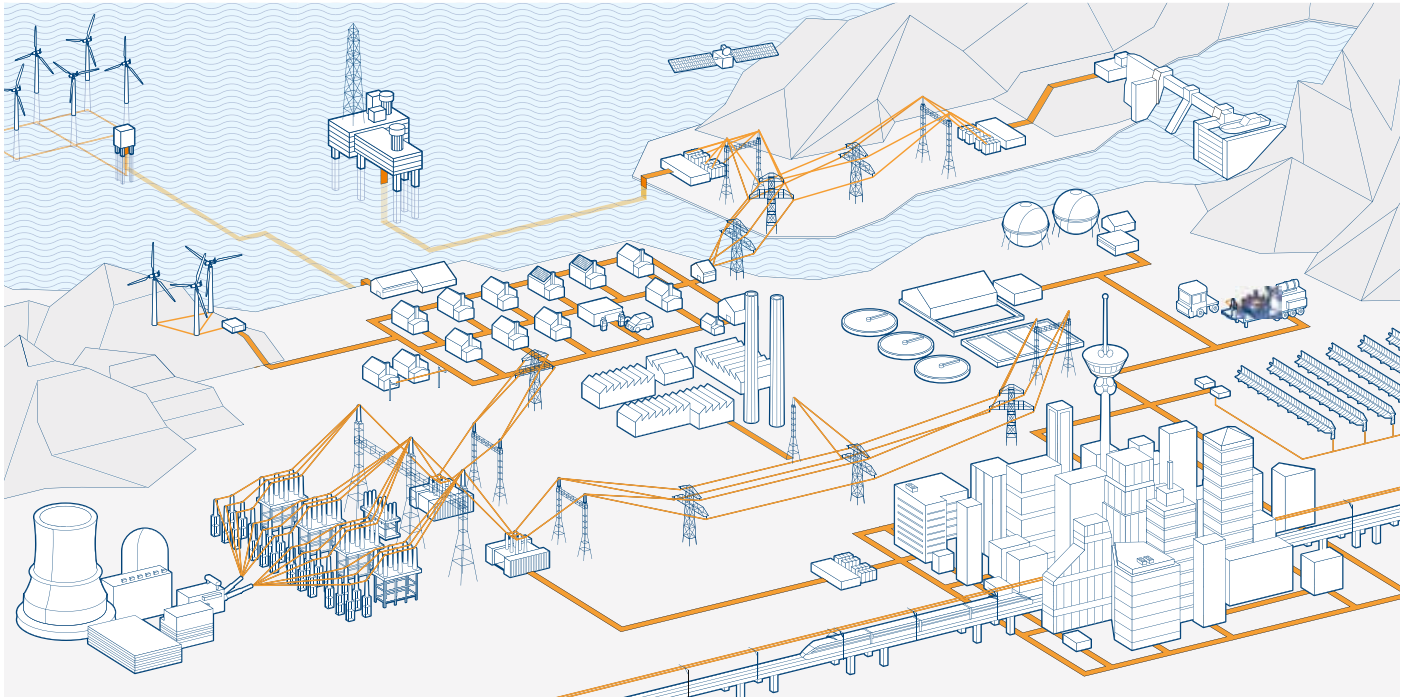
- Steel frame open drip proof (ODP) motors
- Weather protected, water cooled, fan ventilated
- Cast iron frame (TEFC)
- Air to air cooled (TEAAC) motors

Motors and generators for explosive atmospheres

- IEC and NEMA motors and generators, for all protection types

Synchronous motors

Synchronous generators

- Synchronous generators for diesel and gas engines
- Synchronous generators for steam and gas turbines

Wind power generators

Generators for small hydro

Other motors and generators

- Brake motors
- DC motors and generators
- Gear motors
- Marine motors and generators
- Single phase motors
- Motors for high ambient temperatures
- Permanent magnet motors and generators
- High speed motors
- Smoke extraction motors
- Wash down motors

- Water cooled motors
- Generator sets
- Roller table motors
- Servo motors
- Traction motors

Life cycle services

- Installation and commissioning
- Service contracts
- Preventive maintenance
- Spare parts
- Diagnosis
- Repair and refurbishment
- Site survey and overhaul
- Replacement motors and generators
- Technical support and consulting
- Trainings

Mechanical power transmission components, bearings, gears

Life cycle services and support

From pre-purchase to migration and upgrades

ABB offers a complete portfolio of services to ensure trouble-free operation and long product lifetimes. These services cover the entire life cycle. Local support is provided through a global network of ABB service centers and certified partners.

Pre-purchase

ABB's front-end sales organization can help customers to quickly and efficiently select, configure and optimize the right motor or generator for their application.

Installation and commissioning

Professional installation and commissioning by ABB's certified engineers represent an investment in availability and reliability over the entire life cycle.

Engineering and consulting

ABB's experts provide energy efficiency and reliability appraisals, advanced condition and performance assessments and technical studies.

Condition monitoring and diagnosis

Unique services collect and analyze data to provide early warnings of problems before failures can occur. All critical areas of the equipment are covered.

Maintenance and field services

ABB offers life cycle management plans and preventive maintenance products. The recommended four-level maintenance program covers the entire product lifetime.

Spare parts

Spare parts and support are offered throughout the life cycle of ABB products. In addition to individual spares, tailored spare part packages are also available.

Repair and refurbishment

Support for all ABB motors and generators and other brands is provided by ABB's global service organization. Specialist teams can also deliver emergency support.

Migration and upgrades

Life cycle audits determine the optimum upgrades and migration paths. Upgrades range from individual components to direct replacement motors and generators.

Training

Product and service training courses take a practical approach. The training ranges from standard courses to specially tailored programs to suit customer requirements.

Specialized support

Specialized support is offered through ABB's global service organization. Local units provide major and minor repairs as well as overhauls and reconditioning.

Service contracts

Service contracts are tailored to the customer's needs. The contracts combine ABB's entire service portfolio and 120 years of experience to deploy the optimal service practices.



Contact us

www.abb.com/motors&generators

We reserve the right to make technical changes or modify the contents of this document without prior notice. With regard to purchase orders, the agreed particulars shall prevail. ABB does not accept any responsibility whatsoever for potential errors or possible lack of information in this document.

We reserve all rights in this document and in the subject matter and illustrations contained herein. Any reproduction, disclosure to third parties or utilization of its contents – in whole or in parts – is forbidden without prior written consent of ABB.

© Copyright 2013 ABB.
All rights reserved.

9AKK105928 EN 11-2013