

# Model FT3 Thermal Gas Mass Flow Meter and Temperature Transmitter

For Industrial, Environmental,  
Energy Monitoring and Process  
Control Applications

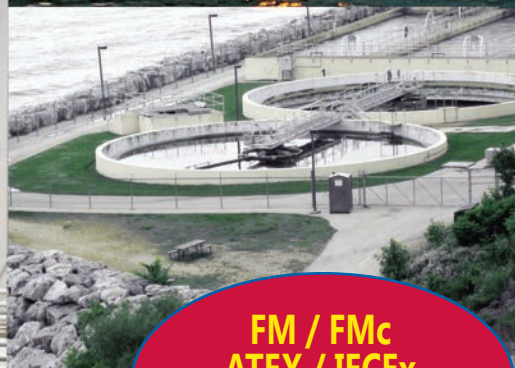

**FM / FMc  
ATEX / IECEx  
APPROVED!**



**Fox Thermal**  
Precision Mass Flow Measurement  
An ONICON Brand

399 RESERVATION RD  
MARINA, CA 93933  
PHONE: 831-384-4300  
FAX: 831-337-5786  
sales@foxthermal.com  
www.foxthermal.com



## Smart, Real-Time Mass Flow Measurement

The Fox Model FT3 measures two important process variables with a single instrument, providing isolated 4-20mA and pulse outputs for flow rate, and a 4-20mA pulse output for process gas temperature or a second flow rate output.

Direct mass flow measurement, exceptional low-flow sensitivity, fast response, and low maintenance requirements distinguish the Fox Model FT3. Virtually immune to changes in temperature and pressure, the flow meter delivers repeatable, accurate mass flow measurement under varying loads. It's rugged, no-moving-parts design is also ideal for high-vibration industrial environments, and enhanced EMI immunity makes it suitable for environments where electric motors, ignitors or dirty power may affect instrument performance.

### Creative Solutions - Calibration Validation with Fox Model FT3

Fox Thermal knows that customers want creative and effective solutions to some of their common process problems. Downtime due to equipment maintenance or calibration costs money and wastes valuable time. Calibration Validation of flow meters in the field provides assurance of the functionality of the meter and avoids the downtime associated with annual calibrations.

Used in succession, Fox's CAL-V™ and Zero CAL-CHECK™ Tests can give you the reassurance that your meter is performing accurately in the field without the need to interrupt flow or send the meter back to the factory. The tests are quick and easy to perform at any time and help with

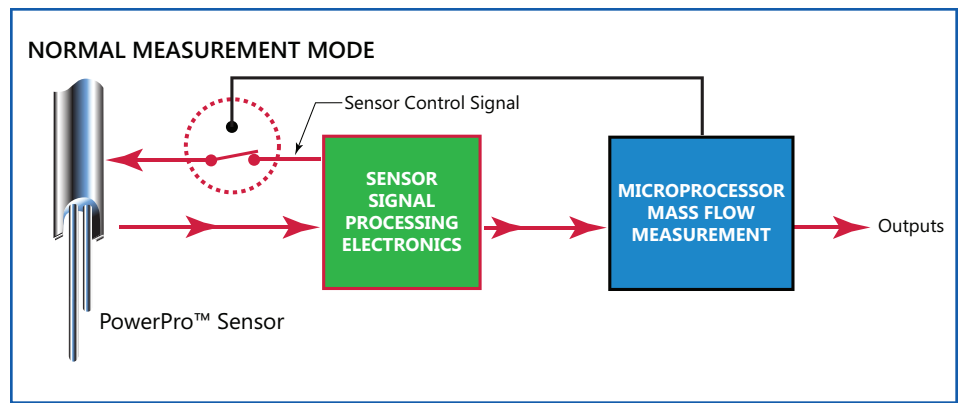

In normal measurement mode the signal processing electronics control the sensor.

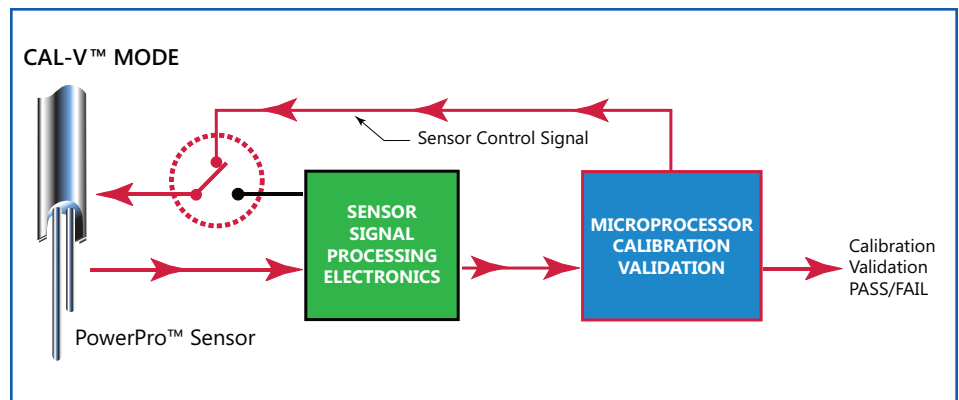

In CAL-V™ mode, the microprocessor controls the sensor and determines the resulting electrical characteristics.

the challenging requirements for measuring the flow of air and gases.

### CAL-V™

The CAL-V™ feature is an in-situ calibration routine that validates the flow meter's calibration accuracy by testing the functionality of the sensor and its associated signal processing circuitry. This innovative approach lets you validate instrument calibration in the pipe, at process conditions, with just a push of a button. At the conclusion of the test, the meter will display a pass/fail message and the CAL-V™ data is saved in the meter for

look-up at any time.

CAL-V™ is an operator-initiated test that can be performed at any flow rate, including zero, and is completed in just three to four minutes. During the test, the meter's microprocessor adjusts the signal to the sensor elements and determines the resulting electrical characteristics. These site-determined characteristics are compared with the data that was collected and stored in the instrument electronics during the original factory calibration. Matching data within established tolerances confirms the meter is measuring accurately.

CALIBRATION VALIDATION: Typical Requirements of Competitive Models	Other Thermal Flow Meters	FT3 with CAL-V™ & Zero CAL-CHECK™
Stop the flow*	Required	Not Required
Remove meter from pipe*		
Disconnect wires from flow meter		
Look up data on flow meter's calibration certificate		
Measure electrical characteristics with volt ohm meter		
Perform calculations to evaluate flow meter performance		
Set process pressure to manufacturer's calibration pressure		
Connect auxiliary test equipment and/or test gases to flow meter		

\*When using a packing gland assembly for Zero CAL-CHECK™

### Zero CAL-CHECK™ Tests

The Zero CAL-CHECK™ tests are used to ensure that the flow meter still retains its original NIST-traceable calibration at zero flow. The test can be performed in one of two ways: In-situ or Out-of-Pipe.

#### In-situ Zero CAL-CHECK™

If zero flow can be established, the sensor does not need to be removed and the procedure can be done in the pipe. If zero flow cannot be established, a Fox Packing Gland Assembly is used to remove the sensor

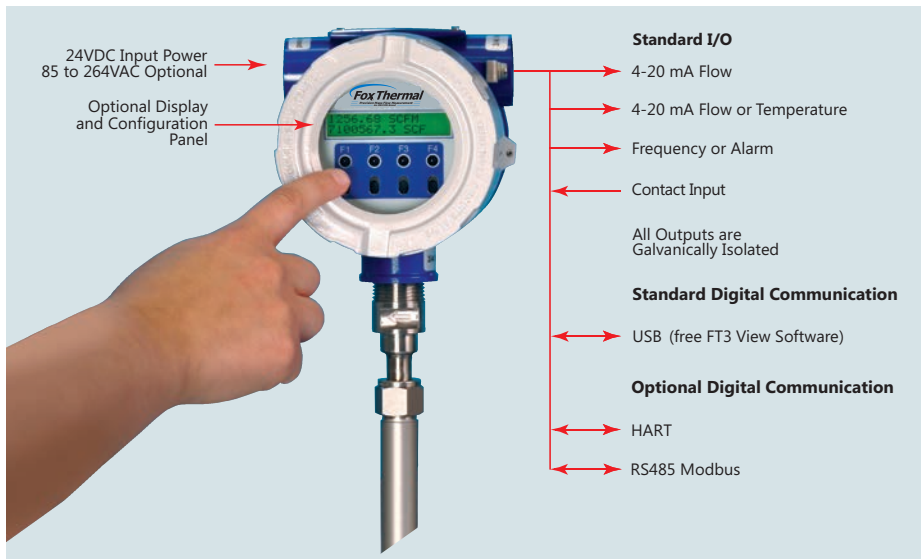

The Model FT3 is a full-featured thermal mass flow meter with a configuration panel that comes equipped with IR buttons for easy configuration of the meter's settings.

from the gas stream to simulate a "no flow" condition.

The test compares sensor characteristics at zero flow with customer-set zero flow baseline and takes less than five minutes to complete after zero flow condition has been established.

#### Out-of-Pipe Zero CAL-CHECK™

If zero flow cannot be established and the meter must be removed from the pipe, this test may be used. The test will compare the sensor characteristics at zero flow at ambient temperature and atmospheric pressure with the factory characteristics. This test can also be performed in less than five minutes once the set up is complete.

#### Easy Accuracy Reporting

Both CAL-V™ and the Zero CAL-CHECK™ Tests can be initiated from the front panel, USB connection, RS485 Modbus or HART. If initiated by Fox's FT3 View™ software tool, CAL-V™ or Zero CAL-CHECK™ Calibration Validation Certificates can be produced at the conclusion of the tests.

This feature is of particular value in environmental monitoring applications, such as flares and vents, where periodic calibration validation is mandated. These tests help operators comply with environmental mandates and eliminates the cost and inconvenience of annual factory calibration. It can also be used to streamline quality assurance, improve process initiatives, and apply scheduled maintenance procedures.

#### Rugged, Reliable Performance

The Fox PowerPro™ sensor operates at a higher power level than competitive thermal flow sensors resulting in improved response time and wider turndown. The PowerPro™ sensor also provides exceptional accuracy at high velocities - up to 60,000 SFPM (280 NMPS).

The Model FT3 features a dual-compartment, explosion-proof electronics enclosure. One compartment houses the instrument electronics and the second compartment is accessible for wiring. A waterproof seal between the compartments helps prevent moisture damage and maintain the integrity of the instrument electronics.

An optional on-board 2 line x 16 character backlit display is available to view flow rate, total flow, elapsed time, process gas temperature and alarms. The display is also used in conjunction with the Configuration Panel for field configuration of flow meter settings such as 4-20mA and pulse output scaling, pipe area, zero flow cutoff, flow filtering or damping, display configurations, diagnostics and alarm limits. Optically activated keys provide interface to the flow meter without removing the cover.

The Model FT3 features galvanically-isolated outputs and enhanced EMI immunity. A variety of meter configurations, materials, process connections and output options offer improved design flexibility, lower cost-of-ownership and enhanced control capabilities.

The Model FT3 is available in both insertion and inline models. The insertion meter is easily installed with a weld-o-let and compression fitting. The inline model is available in ¼-inch to 6-inch sizes and includes built-in flow conditioners that eliminate the need for long, straight pipe runs.

#### Communications Options

A USB connection is standard on the Model FT3, and Fox's free FT3 View™ software provides complete configuration and remote process monitoring functions. FT3 View™ lets you adjust meter configuration, evaluate transmitter alarm conditions, collect process data, and view measurements from your PC or control station. HART and RS485 Modbus are available options. All digital communication is isolated to provide immunity from electrical interference.

#### NIST Traceable Factory Calibration

Fox calibrations are performed with NIST traceable flow standards. Whether you require a straightforward air calibration or a complex mixed gas calibration, our goal is to achieve the highest accuracy and the fastest turnaround time. The Fox Calibration Lab employs a wide range of gases, gas mixtures, temperatures, pressures and line sizes to simulate actual fluid and process conditions. This real-world approach improves installed accuracy and minimizes measurement uncertainty.



Built-in flow conditioning improves measurement accuracy in space-constrained applications.

**Fox Thermal**  
Precision Mass Flow Measurement  
An ONICON Brand

# Summary Specifications

## Performance Specs

### Flow Accuracy:

- Inline meter: ± 1% of reading ± 0.2% of full scale.
- Insertion meter: ± 1% of reading ± 0.2% of full scale.
- Straight, unobstructed pipe requirement:
  - Inline: 8 diameters upstream; 4 downstream.
  - Insertion: 15 diameters upstream; 10 downstream.
  - Insertion (1/4" size): 6" (152mm) upstream & downstream

Flow Repeatability: ± 0.2% of full scale

Flow Response Time: 0.9 seconds (one time constant)

### Temperature Accuracy:

± 1.8° F (± 1.0° C) -40 to 250° F (-40 to 121° C); ± 3.6° F (± 2.0° C), 250 to 650° F (121 to 343° C); 60 SFPM minimum.

### Calibration:

Factory Calibration to NIST traceable standards  
 CAL-V™ & Zero CAL-CHECK®: In situ, operator-initiated calibration validation

## Operating Specs

### Units of Measurement (field selectable):

SCFM, SCFH, NMPS, NM3/M, NM3/H, NM3/D, NLPS, NLPM, NLPH, MCFD, MSCFD, SCFD, MMSCFD, MMSCFM, SMPS, SM3/D, SM3/H, SM3/M, LB/S, LB/M, LB/H, LB/D, KG/S, KG/M, KG/H, SLPM, SFPM, MT/H

### Flow Rates for Insertion Flow Meter:

15 to 60,000 SFPM (0.07 to 280 NMPS) - Air at 70°F (20°C) & 1 ATM  
 Turndown: up to 1000:1; 100:1 typical

Typical Flow Ranges for Insertion Flow Meters			
Pipe size	SCFM	MSCFD	NM <sup>3</sup> /HR
1.5" (40mm)	0 - 840	0 - 1,220	0 - 1,325
2" (50mm)	0 - 1,400	0 - 2,020	0 - 2,210
2.5" (63mm)	0 - 2,000	0 - 2,880	0 - 3,150
3" (80mm)	0 - 3,100	0 - 4,440	0 - 4,890
4" (100mm)	0 - 5,300	0 - 7,650	0 - 8,360
6" (150mm)	0 - 12,000	0 - 17,340	0 - 18,930
8" (200mm)	0 - 20,840	0 - 30,020	0 - 32,870
10" (250mm)	0 - 32,800	0 - 47,250	0 - 51,740
12" (300mm)	0 - 46,600	0 - 67,180	0 - 73,500

Flow Ranges for Inline Flow Meters			
Pipe size	SCFM	MSCFD	NM <sup>3</sup> /HR
0.25"	0 - 7.5	0 - 10.8	0 - 11.8
0.5"	0 - 125	0 - 180	0 - 200
0.75"	0 - 220	0 - 320	0 - 350
1"	0 - 360	0 - 520	0 - 570
1.25"	0 - 625	0 - 900	0 - 990
1.5"	0 - 840	0 - 1,220	0 - 1,325
2"	0 - 1,400	0 - 2,020	0 - 2,210
2.5"	0 - 2,000	0 - 2,880	0 - 3,150
3"	0 - 3,100	0 - 4,440	0 - 4,890
4"	0 - 5,300	0 - 7,650	0 - 8,360
6"	0 - 12,000	0 - 17,340	0 - 18,930

Note: Standard conditions of air at 70°F and one atmosphere. Consult factory for other gases and for flow ranges above those listed. Inline meters above 5,000 SCFM (7,900 NM<sup>3</sup>/H) air may require third party Calibration. Contact Fox.

### Gas Pressure (maximum):

- Insertion: 500 psig (34.5 barg)
- 316 SS inline with NPT ends: 500 psig (34.5 barg)
- 316 SS inline with 150 lb. flanges: 230 psig (16 barg)
- CS inline with NPT ends: 300 psig (20.1 barg)
- CS inline with 150 lb. flanges: 285 psig (19.7 barg)
- Retractor: 125 psig (8.6 barg)
- High pressure retractor: NPT 600 psig (41.4 barg), ANSI 150 flange & ANSI 300 flange, no valve supplied.

### Notes:

- Check with factory for higher pressure options.
- With teflon ferrule option, gas pressure max: 60psig (4.1 barg)
- Pressure ratings stated for temperature of 100°F (38°C).

Relative Humidity: 90% RH maximum; non-condensing

Temperature (see Agency Approvals table to the right):

ST sensor: -40 to 250°F (-40 to 121°C)

HT Sensor: -40 to 650°F (-40 to 343°C)

### Enclosure Ambient Temperature:

- Without display or AC power supply: -40 to 158°F (-40 to 70°C)
- With display and/or AC power supply: -4 to 158°F, (-20 to 70°C)
- Remote sensor junction box: -40 to 212°F (-40 to 100°C)

### Input Power:

- 24 VDC  $\pm$ (± 10%), 0.7 Amps (standard DC power)
- 100 to 240VAC~(+10%/-15%), 50-60Hz, 0.2 Amps (with AC power option)
- Note: Fluctuations of AC and DC power supply are not to exceed ±10% of rating.
- Class I Equipment (Electrical Grounding Required for Safety).
- Installation (Over-voltage) Category II for transient over-voltages.

### Outputs:

- Two isolated 4-20mA outputs(output one is for flow rate and output two is programmable for flow rate or temperature); fault indication per NAMUR NE43.
- Isolated pulse output 0 to 100Hz, 5 to 24 volts p/p for flow (the pulse output can be used as an isolated solid state output for alarms); 10mA max.

### Serial Communication:

USB communication port is standard. The free PC-based software tool - FT3 View™ - provides complete configuration, remote process monitoring, and data logging functions.

Optional serial communication: HART and RS485 Modbus.

### 4-20mA Loop Verification:

Simulation mode used to align 4-20mA output with the input to customer's PLC/DCS.

## Physical Specs

Sensor Material: 316 stainless steel standard; Hastelloy C276 optional

Enclosure: NEMA 4X (IP67), Aluminum, dual conduit entries with 3/4" NPT or optional M20 x 1.5mm.

Cabling to remote enclosure: 5-conductor, 18 AWG, twisted, shielded, 100 feet maximum.

### Retractor Assemblies:

- Packing gland assembly: 125 psig (8.6 barg ) max.
- High pressure (crank) retractor: NPT 600 psig (41.4 barg), ANSI 150 flange & ANSI 300 flange, no valve supplied.

### Insertion Flow Meter Installation:

Fox-supplied compression fitting connects to customer-supplied 3/4" female coupling welded to pipe.

Dimensions: [www.foxthermal.com/literature/](http://www.foxthermal.com/literature/)

## Agency Approvals

- CE: Approved
- EMC Directive; 2004/108/EC
- Emissions and immunity Testing: EN61326-1:2008,
- Low Voltage Directive (LVD): 2006/95/EC
- Product Safety Testing: EN 61010-1: 2010
- Pressure Equipment Directive (PED): 97/23/EC; Weld Testing: EN ISO 15614-1 and EN ISO 9606-1, ASME B31.3

### FM/FMc: Approved

Class I, Div. 1, Gps B, C, D; Class II, Div. 1, Gps E, F, G; and Class III, Div. 1; T3C, Ta = -40° to 70°C; Class I, Zone 1, AEx/Ex d IIB + H2 (T6, T4 or T1\*); Ta = -20°C to 70°C; Type 4X, IP67.

### ATEX (FM12ATEX0034X): Approved

II 2 G Ex d IIB + H2 (T6, T4 or T1\*); Gb Ta = -20°C to 70°C; IP67  
 II 2 D Ex tb IIIC (T85°C, T135°C or T450°C\*) Db Ta = -20°C to 70°C; IP67

### IECEX (IECEX FMG 12.0010X): Approved

Ex d IIB + H2 (T6, T4 or T1\*) Gb Ta = -20°C to 70°C; IP67  
 Ex tb IIIC (T85°C, T135°C or T450°C\*) Db Ta = -20°C to 70°C; IP67\*\*

Model Code		Temp. Code (Gas)		Temp. Code (Dust)	
Encl.	Sensor	Mn. Encl.	Remote	Mn. Encl.	Remote
E1	ST	T4	N/A	135°C	N/A
E2	ST	T4	N/A	135°C	N/A
E3	ST	T6	T4	85°C	135°C**
E4	ST	T6	T4	85°C	135°C**
E3	HT	T6	T1	85°C	450°C**
E4	HT	T6	T1	85°C	450°C**

\*Temperature code ratings for Zones are dependent on external process temperature factors and equipment enclosure configuration. See table above for specific temperature code ratings.

\*\*The IECEx dust rating does not apply to the Remote Enclosure.