

# Fox Thermal

THERMAL MASS FLOW METER  
& TEMPERATURE TRANSMITTER



**Model FT4A**



## Notice

---

**DISCLAIMER**

*This publication must be read in its entirety before performing any operation. Failure to understand and follow these instructions could result in serious personal injury and/or damage to the equipment. Should this equipment require repair or adjustment beyond the procedures given herein, contact the factory at:*

**FOX THERMAL INSTRUMENTS, INC.  
399 RESERVATION ROAD  
MARINA, CA 93933  
TELEPHONE: 831-384-4300  
FAX: 831-337-5787  
EMAIL: SERVICE@FOXTHERMAL.COM**

**Download Technical Data Sheets from our website:  
[www.foxthermal.com](http://www.foxthermal.com)**

***Fox Thermal Instruments, Inc. (Fox Thermal) believes that the information provided herein is accurate; however, be advised that the information contained herein is NOT a guarantee for satisfactory results. Specifically, this information is neither a warranty nor guarantee, expressed or implied, regarding performance, merchantability, fitness, or any other matter with respect to the products; nor recommendation for the use of the product/process information in conflict with any patent. Please note that Fox Thermal reserves the right to change and/or improve the product design and specification without notice.***



**Fox Thermal FT4A Manuals:**

- **Fox Thermal FT4A View™ Manual**

*All Fox Thermal Manuals and software available in English only.*

# Table Of Contents

1. Introduction	Page 4
a. Menu Trees	Page 4
b. Quick Start Guide	Page 13
2. Installation (Mechanical)	Page 17
a. Installation Depth	Page 21
b. Orientation of Flowmeter	Page 22
c. Rotating the Probe/Enclosure	Page 23
d. Changing the Orientation of the Display	Page 29
e. Mounting Instructions	Page 24
3. Wiring (Electrical)	Page 29
a. General Wiring	Page 30
b. Input Power	Page 30
c. Signal Wiring	Page 31
d. Pulse/Alarm Wiring (optional feature)	Page 33
e. RS485 Wiring: Modbus RTU (optional feature)	Page 35
f. HART wiring	Page 36
4. Operation (Standard Operation)	Page 38
a. Start Up	Page 38
b. Programming	Page 40
c. CAL-V <sup>®</sup>	Page 57
d. Gas-SelectX <sup>®</sup>	Page 60
5. Communication Protocols	Page 64
a. RS485 Modbus RTU	Page 64
b. HART	Page 72
6. Maintenance	Page 78
a. Precautions	Page 72
b. Troubleshooting	Page 84
7. Appendices	Page 89
a. Specifications	Page 100
b. Agency Approvals	Page 91
c. Dimensions	Page 92
d. Warranty	Page 97
e. Returning your meter	Page 98
8. Glossary of Terms and Abbreviations	Page 100
9. Index	Page 101

# Introduction

Fig. 1.1: FT4A Menu Tree - Main Menu

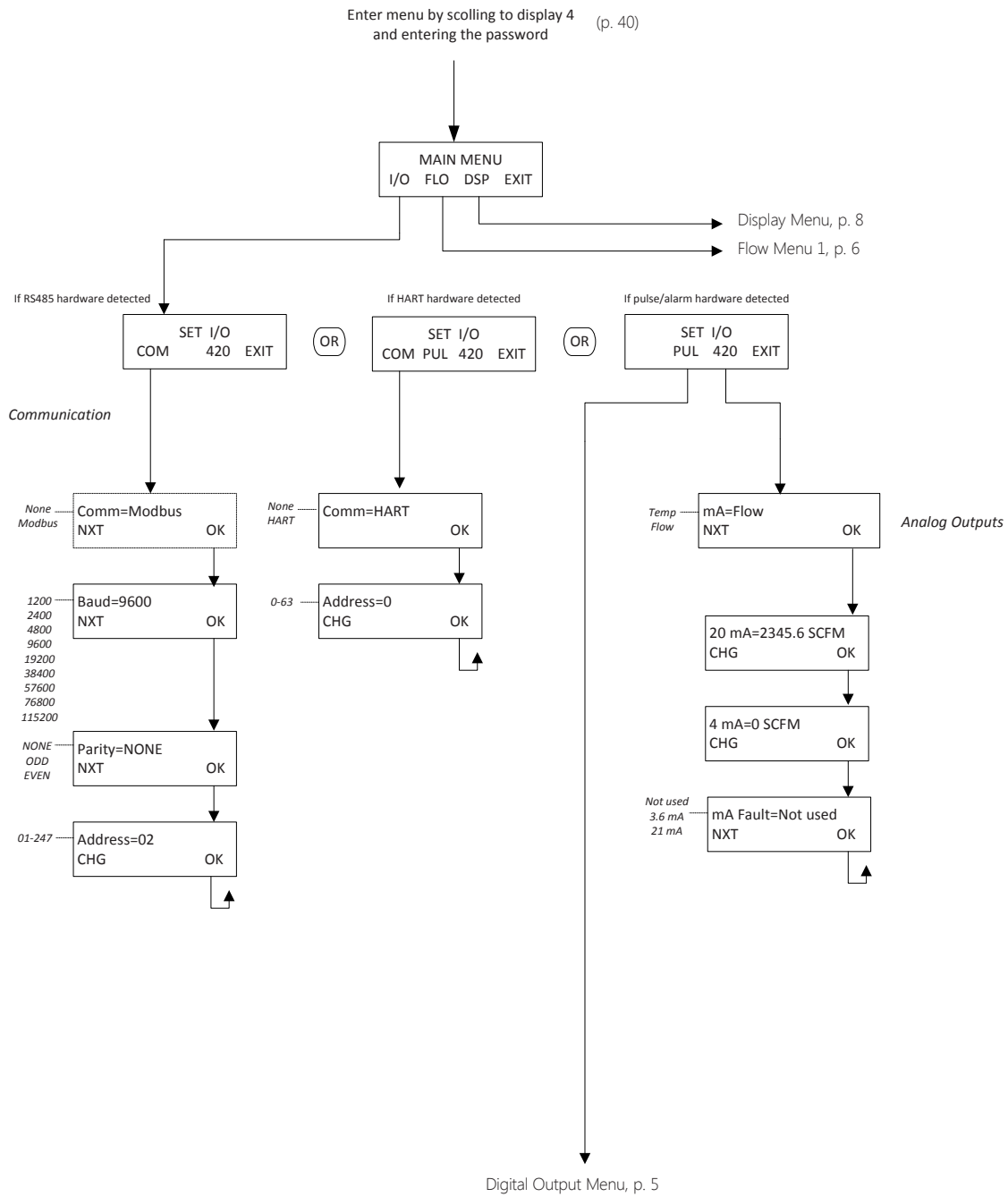

# Introduction

Fig. 1.2: FT4A Menu Tree - Digital Output

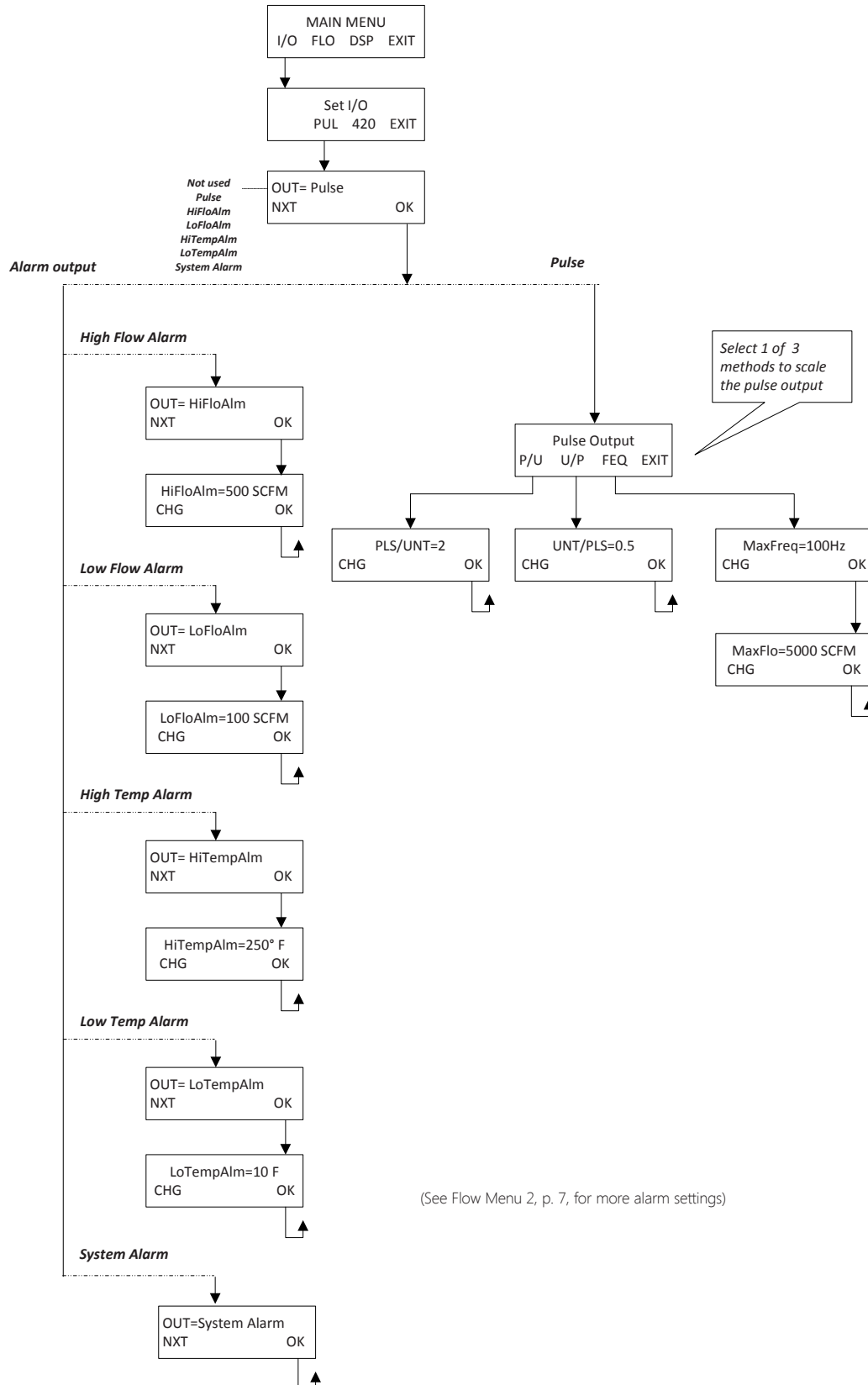

# Introduction

Fig. 1.3: FT4A Menu Tree - Flow Menu 1

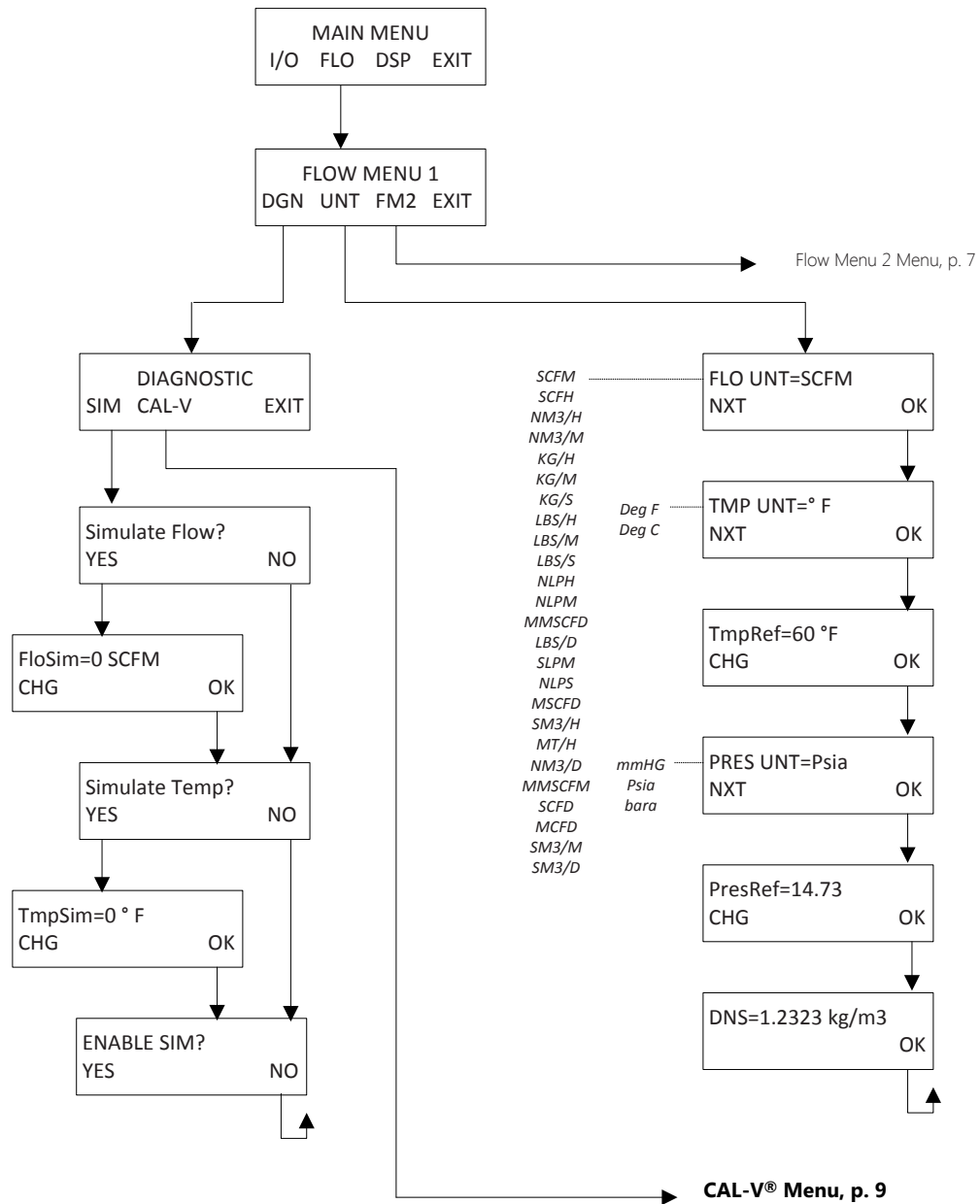

# Introduction

Fig. 1.4: FT4A Menu Tree - Flow Menu 2

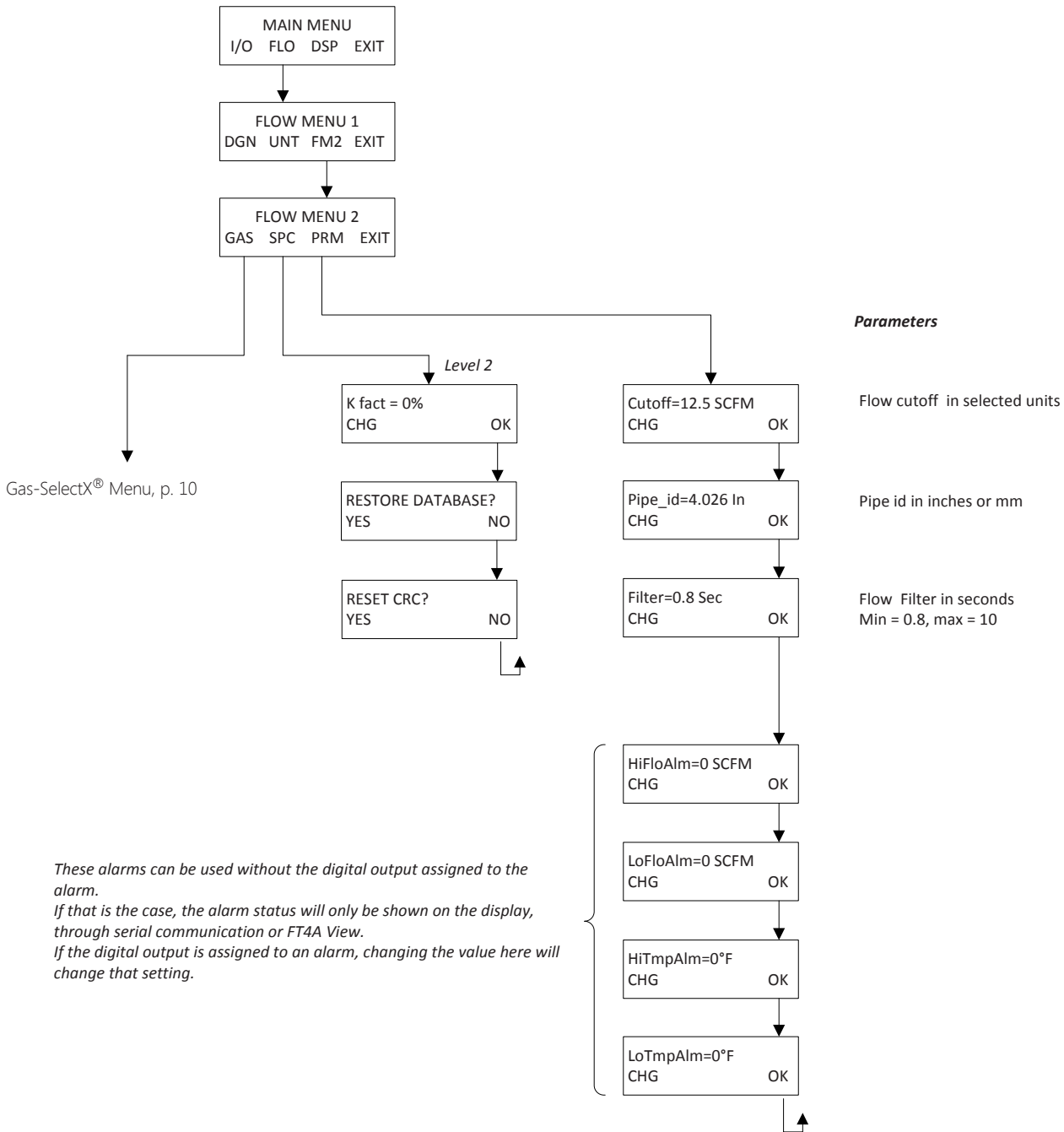

# Introduction

Fig. 1.5: FT4A Menu Tree - Display Menu

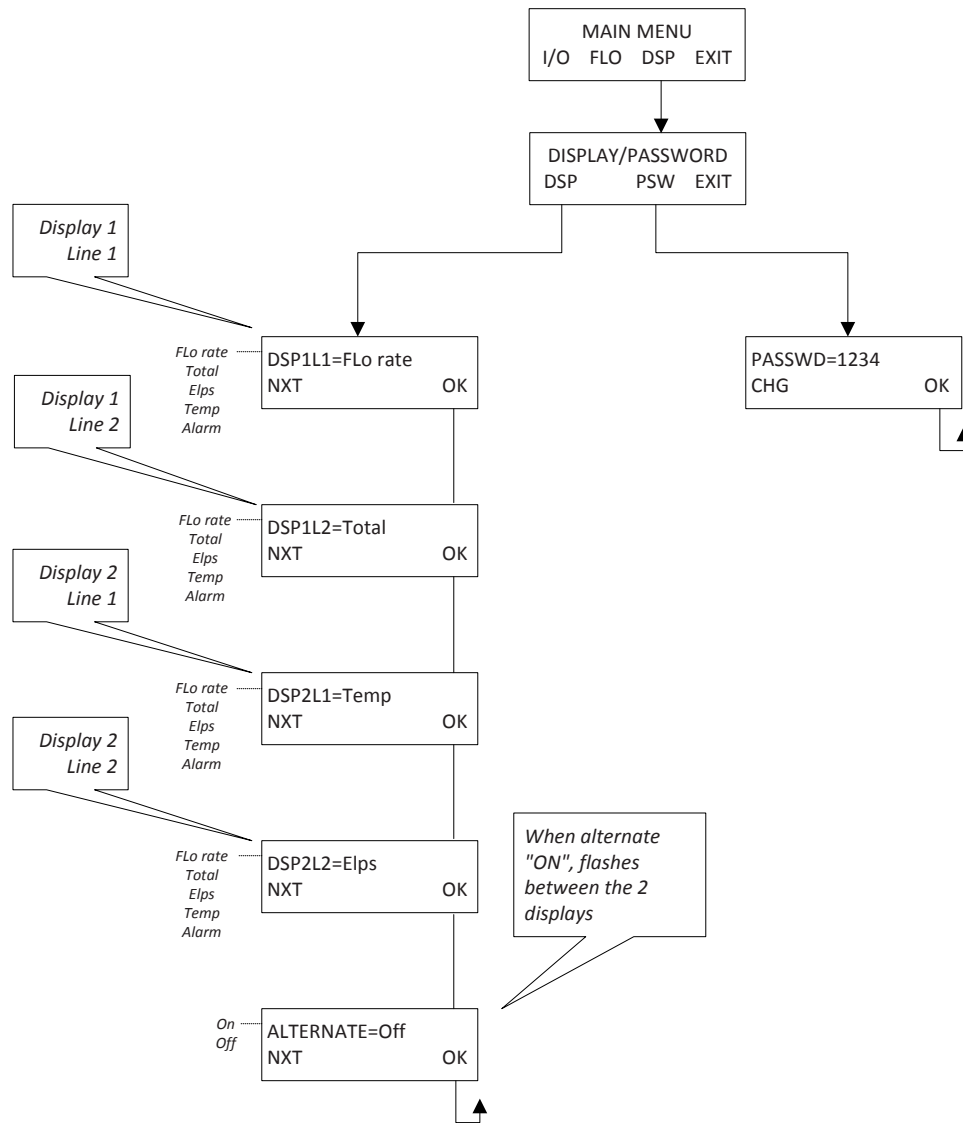

**NOTE! All readings updated every 100 milliseconds except Total which is done every second**

- Flo Rate = Flow rate of process gas
- Total = Total flow of process gas
- Elps = Elapsed time since reset of flow total
- Temp = Temperature of process gas
- Alarm = Notification of errors; diagnostic errors



# Introduction

Fig. 1.6: FT4A Menu Tree - CAL-V<sup>®</sup> Menu

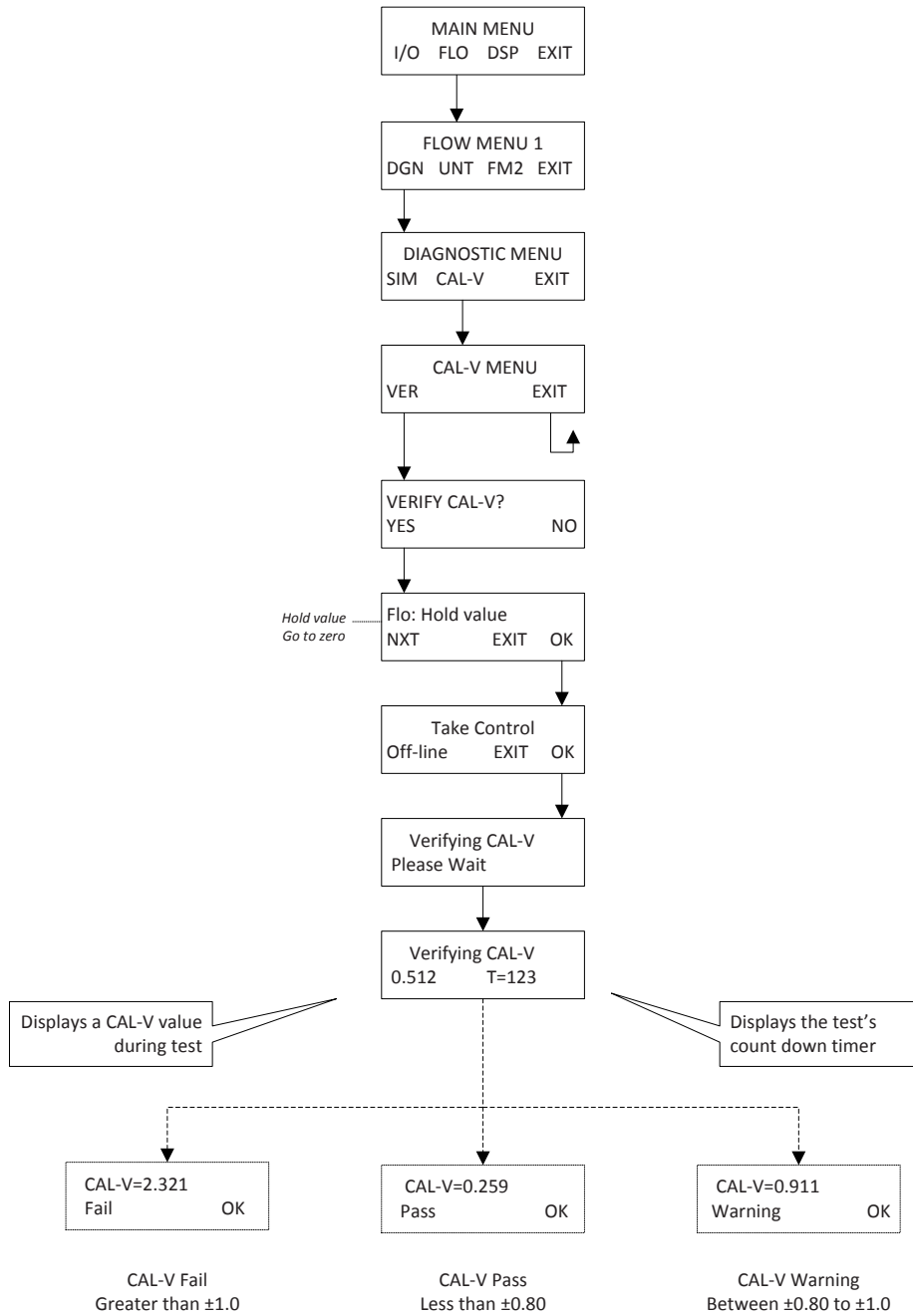

# Introduction

Fig. 1.7: FT4A Menu Tree - Gas-SelectX<sup>®</sup> Menu

The most recent list of available gases can be found on the Fox Thermal website: [www.foxthermal.com](http://www.foxthermal.com)

INTRODUCTION

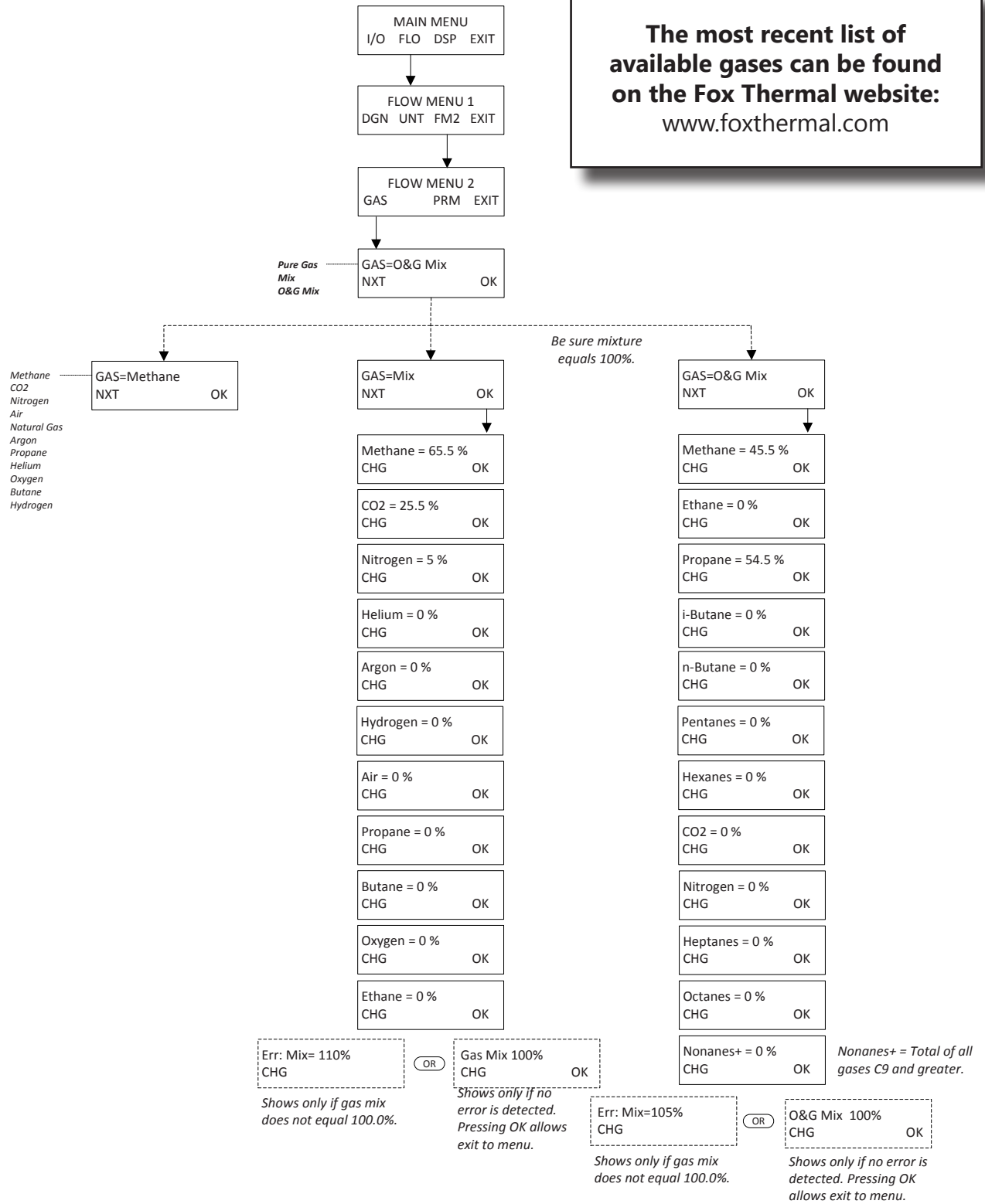

# Introduction

Fig. 1.8: FT4A Menu Tree - Log Menu 1

Enter Log Menu: Press F1 & F2 at the same time  
Press F4 to return to normal mode

F3 & F4 pressed at the same time will  
initiate a "Total" reset

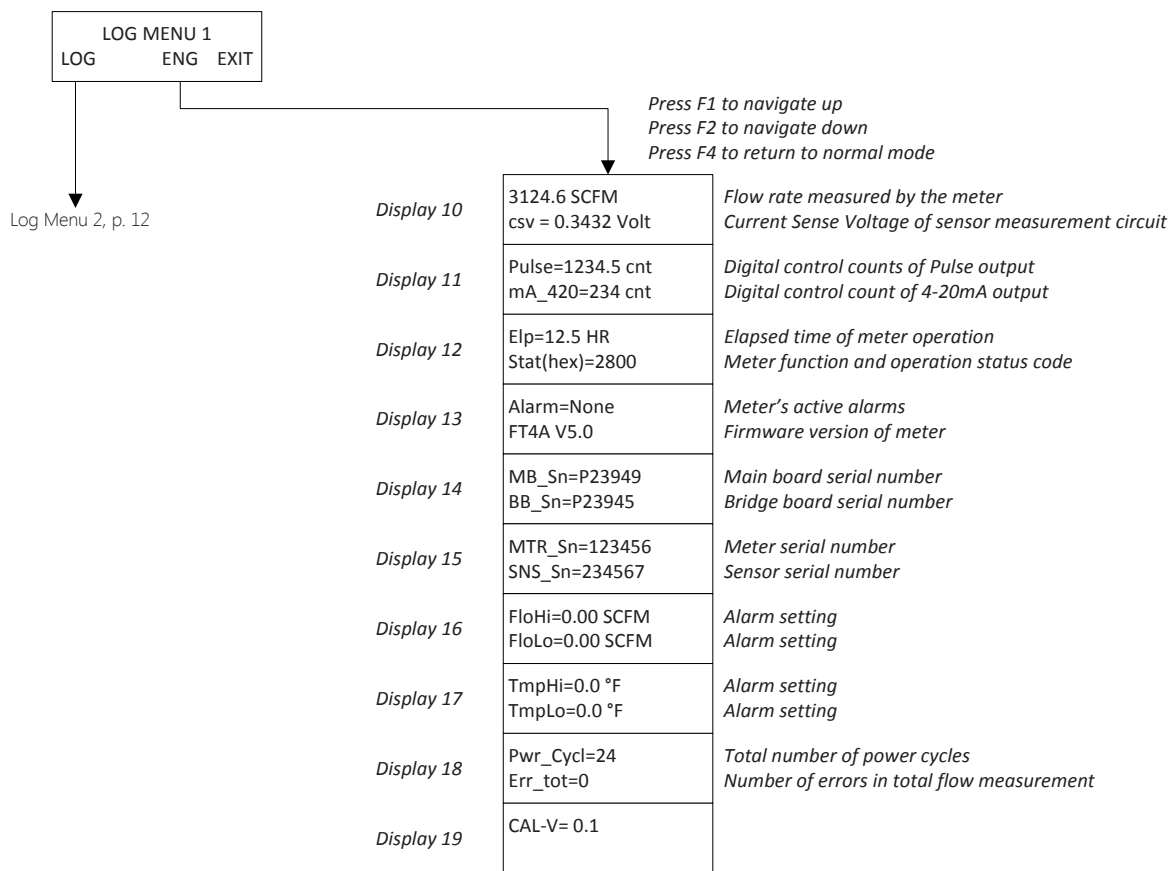

# Introduction

Fig. 1.9: FT4A Menu Tree - Log Menu 2

Enter: Press F1 & F2 at the same time  
Press F4 to return to normal mode



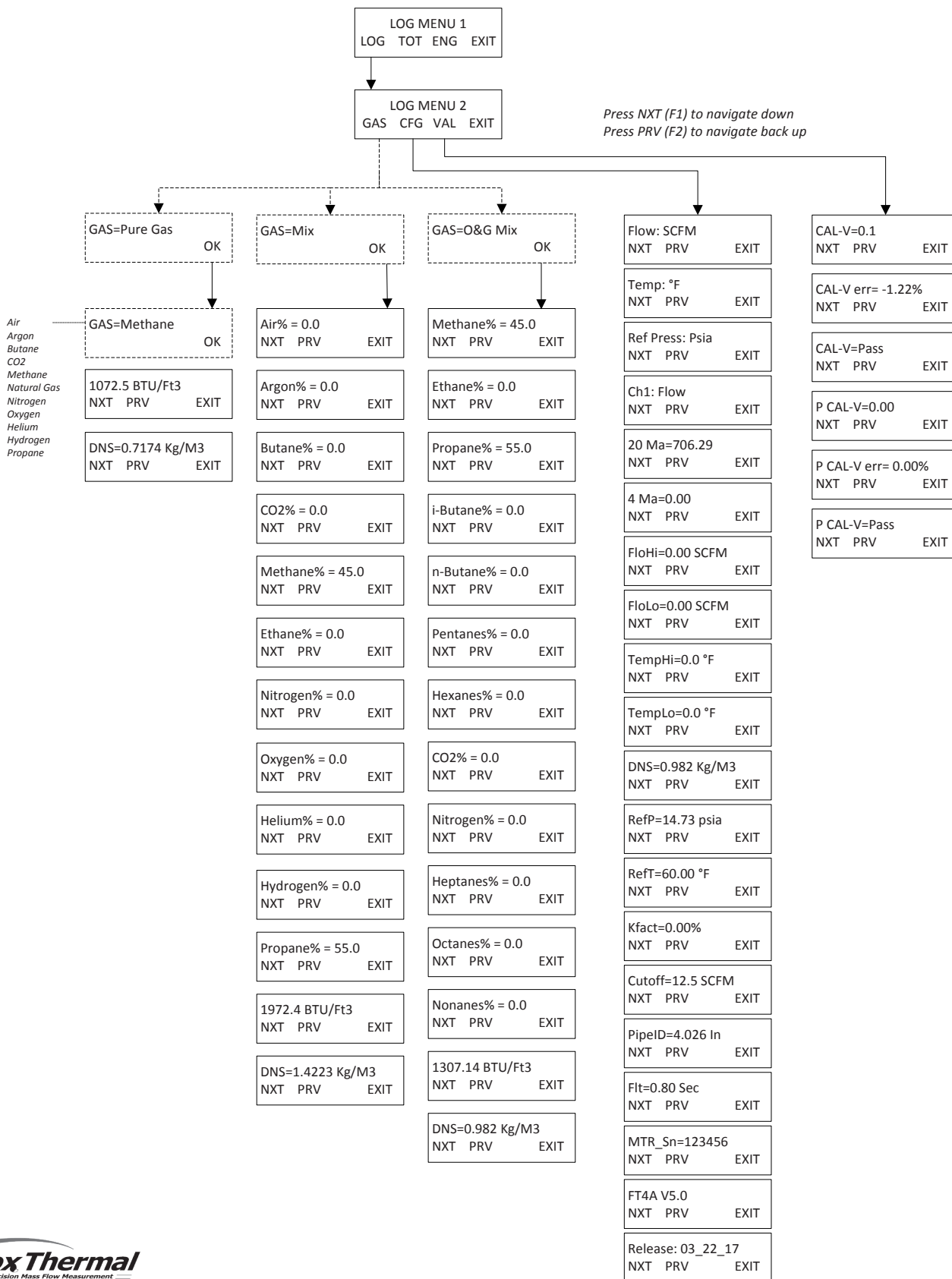

F3 & F4 pressed at the same time will  
initiate a "Total" reset

Press NXT (F1) to navigate down  
Press PRV (F2) to navigate back up

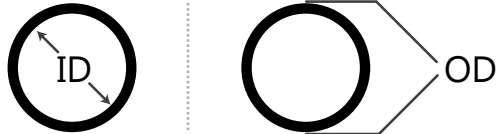
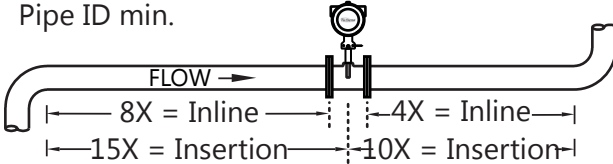
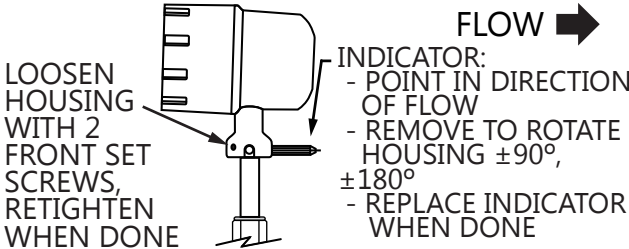
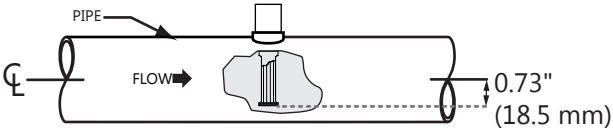

# Quick Start Guide

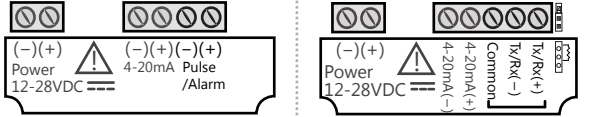
Use the table below as a guide while using the worksheet on the next page to record your notes. **NOTE!** Please read the entire Quick-start procedure before beginning installation.

1.	Record inside diameter (ID) not outside diameter (OD). Ensure the actual pipe ID matches the pipe ID shown on the factory calibration certificate. If IDs do not match, refer to p. 52.	
2.	Record upstream and downstream straight-pipe requirements based on Pipe ID and meter style (insertion or inline). [refer to p. 20 for more information] If FC10 Flow Conditioners ordered, refer to document #107679 for further instructions.	 <p>Pipe ID min.</p> <p>8X = Inline      4X = Inline</p> <p>15X = Insertion      10X = Insertion</p>
3.	<p>a. The Flow Direction Indicator must point in the direction of flow.</p> <p>b. The Indicator can also be used to change the orientation of the housing for a better view of the meter's display. Note that the 2 set screws must be loosened before the housing will turn.</p> <p>[refer to p. 21 for more info]</p>	 <p>FLOW →</p> <p>INDICATOR:</p> <ul style="list-style-type: none"> <li>- POINT IN DIRECTION OF FLOW</li> <li>- REMOVE TO ROTATE HOUSING ±90°, ±180°</li> <li>- REPLACE INDICATOR WHEN DONE</li> </ul> <p>LOOSEN HOUSING WITH 2 FRONT SET SCREWS, RETIGHTEN WHEN DONE</p>
4.	Ensure correct probe depth setting. If using 1 1/2" size pipe, please see note on p. 21.	 <p>PIPE</p> <p>FLOW →</p> <p>0.73" (18.5 mm)</p>
5.	Open the housing. If needed, the orientation of display can be rotated in 90° increments for a better view.	 <p>ACCESS DISPLAY BY UNSCREWING COVER</p> <p>REMOVE SCREWS ON DISPLAY TO ROTATE DISPLAY ±180°</p>
6.	Ensure power wiring and 4-20mA wiring are properly connected	 <p>(-) (+)      (-) (+)</p> <p>Power      4-20mA</p> <p>12-28VDC</p>
7.	Verify you have the proper output signal wiring setup based on model type (Pulse/ Alarm or communication protocol)	 <p>(-) (+)      (-) (+) (-) (+)</p> <p>Power      4-20mA Pulse /Alarm</p> <p>12-28VDC</p> <p>Common      Tx/Rx (+)      Tx/Rx (-)</p>
8.	Power on the flow meter	
9.	Check the remaining flow meter settings: access either through the front panel or FT4A View™ software. Record settings in the spaces given on the following page.	

# Quick Start Guide

Before powering on your meter, use this worksheet to record your notes.

	Item to verify	Serial Number:	Serial Number:	Serial Number:	Serial Number:
1.	What is the Pipe ID?	ID =	ID =	ID =	ID =
2.	Calculate the Upstream/Downstream straight-pipe requirements	UP = DN =	UP = DN =	UP = DN =	UP = DN =
3.	a. Is the flow indicator pointed in direction of flow? b. Must the housing be rotated for easy viewing?	Y / N Y / N	Y / N Y / N	Y / N Y / N	Y / N Y / N
4.	Is the probe depth setting correct?	Y / N	Y / N	Y / N	Y / N
5.	Have you rotated the display for easier viewing?	Y / N	Y / N	Y / N	Y / N
6.	Verify proper power wiring setup				
7.	Verify proper output wiring setup				

After powering on your meter, check items A - E below by accessing the meter settings either through the front panel of the meter's display or by using the FT4A View™ software tool.

A.	Which flow units have been set in meter? (SCFM, KG/H, etc..)				
B.	Correct values for reference temperature and pressure?	Y / N	Y / N	Y / N	Y / N
C.	Confirm the pipe ID listed above same as "Pipe_id="				
D.	Verify the 4mA and 20mA meter settings	4mA = 20mA =	4mA = 20mA =	4mA = 20mA =	4mA = 20mA =
E.	Confirm the correct gas is selected for your application in the Gas-SelectX® menu				

If you are experiencing any problems after completing this procedure, please call the Fox Thermal Service Department at 831-384-4300 to review this information.

## Introduction

---

Thank you for purchasing the Model FT4A Thermal Gas Mass Flow Meter from Fox Thermal. The Model FT4A is one of the most technically advanced flow meters in the world. Extensive engineering effort has been invested to deliver advanced features, accurate measurement performance and outstanding reliability.

This Instruction Manual contains the electrical and mechanical installation instructions as well as details for programming, maintaining and troubleshooting the meter. This manual is divided into the following sections: Introduction, Installation, Wiring, Operation, Maintenance, Troubleshooting, Appendices, Glossary and Index.

### Theory of Operation

The Model FT4A is an innovative Thermal Mass Gas Flow Meter and Temperature Transmitter. It is microprocessor-based and field programmable. The FT4A thermal sensor operates on the law that gases absorb heat. A heated sensor placed in an air or gas stream transfers heat in proportion to the stream's mass velocity. There are two sensor elements. One sensor element detects the gas temperature and a second element is maintained at a constant temperature above the gas temperature. The energy transferred from the heated element is proportional to the mass flow velocity. The FT4A flow meter maintains accurate flow measurement over a large temperature and pressure range.

### Mass Flow

The Model FT4A measures mass flow; an advantage over other flow meters which measure volumetric flow rate. Volumetric flow is incomplete because temperature and pressure are unknown and must be measured separately. For example, the mass flow of a gas depends on its temperature and pressure. As temperature and pressure changes, the gas volume changes but not its mass. Therefore a device measuring mass flow is independent of temperature and pressure changes. The Model FT4A provides a direct measurement of gas flow in Mass units (kg/hr, lb/hr), standard units (SCFM, SLPM) or normal units (NM3/hr, NLPM) with no additional temperature or pressure measurements required.

### Flow Calibration

The Fox Thermal Calibration Lab maintains instrument calibration data on every flow meter. Calibration files include details on process conditions, customer gas, line size and other information. All NIST-traceable equipment utilized for the calibration procedure is identified on the Calibration Certificate, which is sent with every flow meter.

### DDC-Sensor™ Technology Description

The Fox Thermal DDC-Sensor™ is a new state of the art sensor technology used in the Fox Thermal Model FT4A Thermal Gas Flow Meter. The DDC-Sensor™, a Direct Digitally Controlled sensor, is unlike other thermal flow sensors available on the market. Instead of using traditional analog circuitry, the DDC-Sensor™ is interfaced directly to the FT4A microprocessor for more speed and programmability. The DDC-Sensor™ quickly and accurately responds to changes in process variables by utilizing the microprocessor to determine mass flow rate, totalized flow, and temperature.

## Installation

Fox Thermal's DDC-Sensor™ provides a technology platform for calculating accurate gas correlations. The FT4A correlation algorithms allow the meter to be calibrated on a single gas in the factory while providing the user the ability to select other gases in the Gas-SelectX® gas menu. Fox Thermal's Model FT4A with its DDC-Sensor™ and state-of-the-art correlation algorithms provide an accurate, multi-gas-capable thermal gas flow meter.

### I/O Description

The FT4A features a galvanically isolated 4-20mA analog output with HART communication option and a second output for pulse or RS485 Modbus RTU. There is also a USB port for interfacing with a laptop or computer. The 4-20mA output can be configured for flow rate or process gas temperature and can be scaled by the user. The pulse output can be used for pulse or alarm, is programmable to represent flow rate and can be scaled for maximum flow/maximum frequency, units-per-pulse or pulse-per-units. The maximum frequency is 100 Hz.

FT4A View™ interfaces to the USB port and is a free PC-based software program that displays flow meter readings and permits flow meter configuration. The software is available for download on the Fox Thermal website. Industry standard communication options are available including optional RS485 Modbus RTU or HART.

### FT4A Functional Diagram

An on-board 2 line x 16 character backlit LCD display shows flow rate, total flow, elapsed time, process gas temperature, and alarms. The display is also used in conjunction with the Configuration Panel for field configuration of flow meter settings such as 4-20mA scaling, frequency output scaling, pipe area, zero flow cutoff, flow filtering or dampening, display configurations, diagnostics, and alarm limits.

Fig. 2.1: FT4A Function Diagram

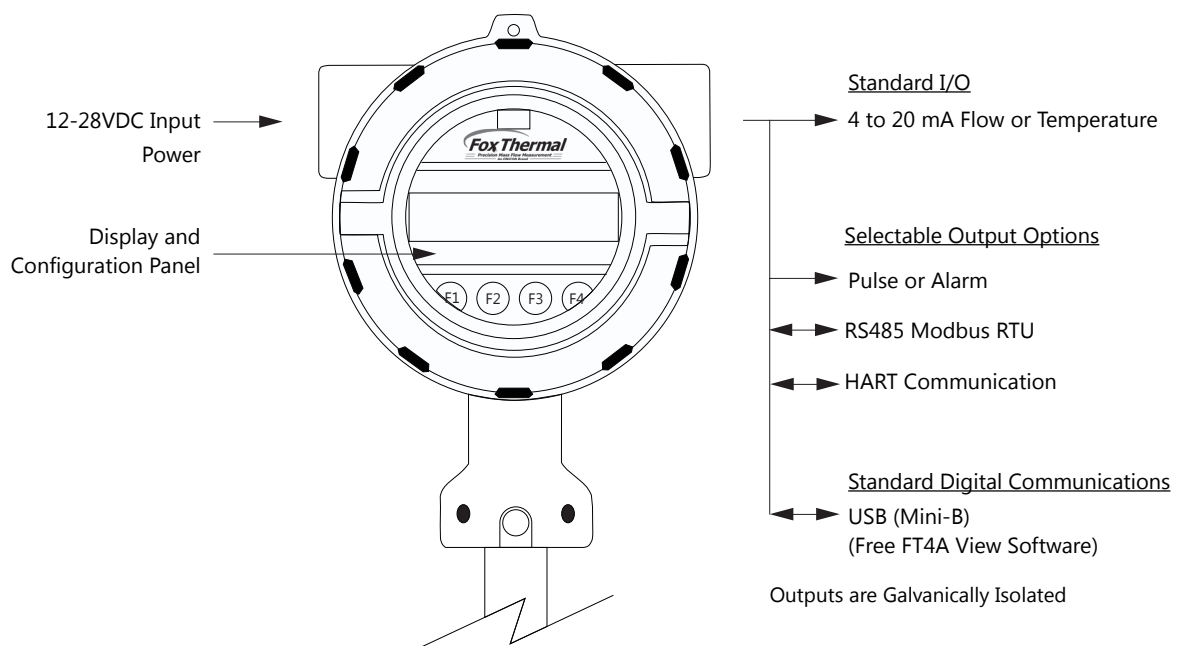



# Installation

## Scope

This section describes how to install the Fox Thermal Model FT4A Flow Meter and how to get started. Installation methods will vary according to the flow meter type (insertion or inline).

For Insertion Types:

1. Determine lateral position on the pipe
2. Verify sensor installation depth
3. Determine sensor orientation in relation to sensor length and direction of flow
4. Determine if the display orientation must be changed
5. Ensure proper tightening of compression fitting for mounting meter

For Insertion Type Meters with FC10 Flow Conditioners:

Please refer to Document #107679, FC10 Installation INstructions for more information about how to install insertion meters with the FC10 Flow Conditioners.

For Inline Types

1. Determine lateral position on the pipe
2. Ensure the correct flow body orientation in relation to direction of flow in pipe
3. Determine if the display orientation must be changed
4. Ensure proper tightening of compression fitting for mounting meter

Installation procedures must be performed using a combination of the end user's best engineering practices, in compliance with local codes, and manufacturer's recommendations.

### Specific Conditions of Use:

- The flameproof joints of the equipment are not intended to be repaired. Consult the manufacturer if dimensional information on the flameproof joints is necessary.
- The flamepaths of the equipment are not intended to be repaired. Consult the manufacturer if repair of the flamepath joints is necessary
- Follow the manufacturer's instructions to reduce the potential of an electrostatic charging hazard.

## Installation

---

### General Precautions



The following general precautions should be observed:

1. Exercise care when handling the flow meter to avoid damaging the probe, sensor or enclosure.
2. Close any unused conduit openings in the enclosure with plugs certified for your application.
3. The enclosure cover must be closed except during installation or configuration.
4. Mounting FT4A in direct sunlight can cause the temperature inside the enclosure to increase beyond design limits, resulting in failure of LCD display and reduced component life. It is recommended that a sunshade be installed to avoid direct sunlight (see maximum enclosure operating temperature specification).
5. Ensure the flow direction indicator/pointer for the meter is in line with the direction of flow in the pipe.
6. Do not install the FT4A enclosure near an igniter, igniter-controller or switching equipment.
7. Do not install an external power supply in a cabinet containing an igniter controller or switching equipment.
8. For accurate flow measurement: review flow meter placement instructions before installation to ensure a proper flow profile in the pipe.
9. For safety reasons, Teflon ferrules are only appropriate for applications with pressures of 60 psig or less. At higher pressures, use of a Teflon ferrule risks unwanted probe movement or ejection of the probe from the pipe. For all applications above 60 psig, the standard stainless steel ferrule is required.

## Installation

### Instructions for Flow Meter Lateral Placement - Insertion Styles

Install the Model FT4A Insertion style flow meter so that it is far enough away from bends in the pipe, obstructions, or changes in line sizes to ensure a consistent flow profile. Fifteen diameters of straight pipe upstream and ten downstream are required. For example, a 2" pipe would require 30" upstream and 20" downstream, but a 4" pipe would require 60" upstream and 40" downstream.



#### NOTES!

- The probe diameter is  $\frac{3}{4}$ ".
- An irregular flow profile may affect sensor accuracy.

Fig. 2.2: Upstream and Downstream Pipe IDs for Insertion Meters

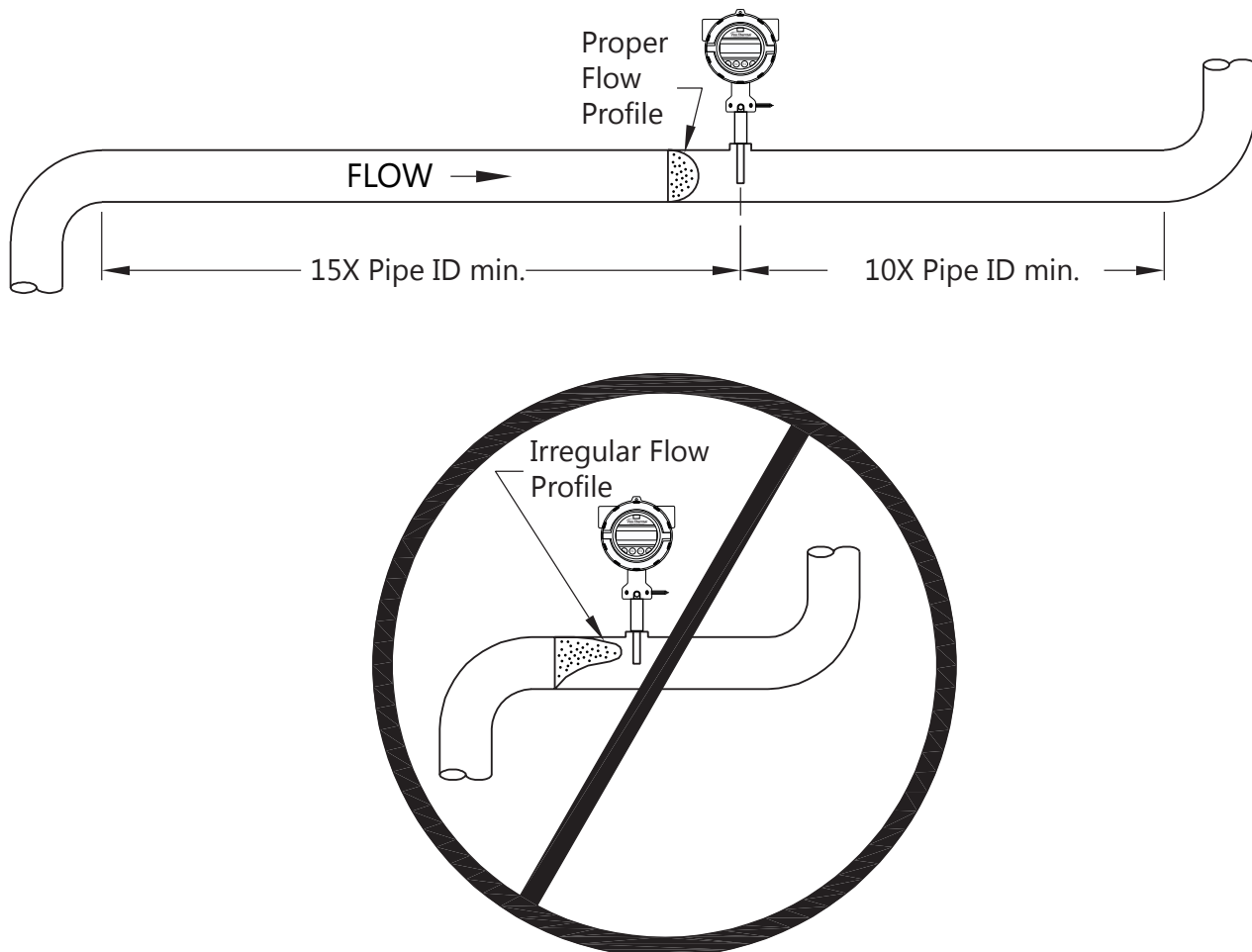

## Installation

### Instructions for Flow Meter Lateral Placement - Inline Styles

Install the Model FT4A Inline style flow meter so that it is far enough away from bends in the pipe, obstructions, or changes in line sizes to ensure a consistent flow profile. Eight diameters of straight pipe upstream and four downstream are recommended (for ¼" meters: 6" (152 mm) of straight, unobstructed pipe upstream and downstream are required).

For example, a 2" pipe would require 16" upstream from the edge of the flow body and 8" downstream from the other end of the flow body, whereas a 4" pipe would require 32" upstream and 16" downstream.

The Model FT4A is welded, threaded or flanged to the customer's pipe. Care should be taken to ensure that the diameter of the mating pipe is the same diameter as the Model FT4A flow body or errors in flow readings can occur. The installation procedure should be a combination of the end user's best engineering practices, in compliance with local codes, and the manufacturer's recommendations.

See Figure 2.3 for a look at upstream and downstream pipe diameters for inline meters.



**NOTES!** An irregular flow profile may affect sensor accuracy.

Fig. 2.3: Upstream and Downstream Pipe IDs for Inline Meters

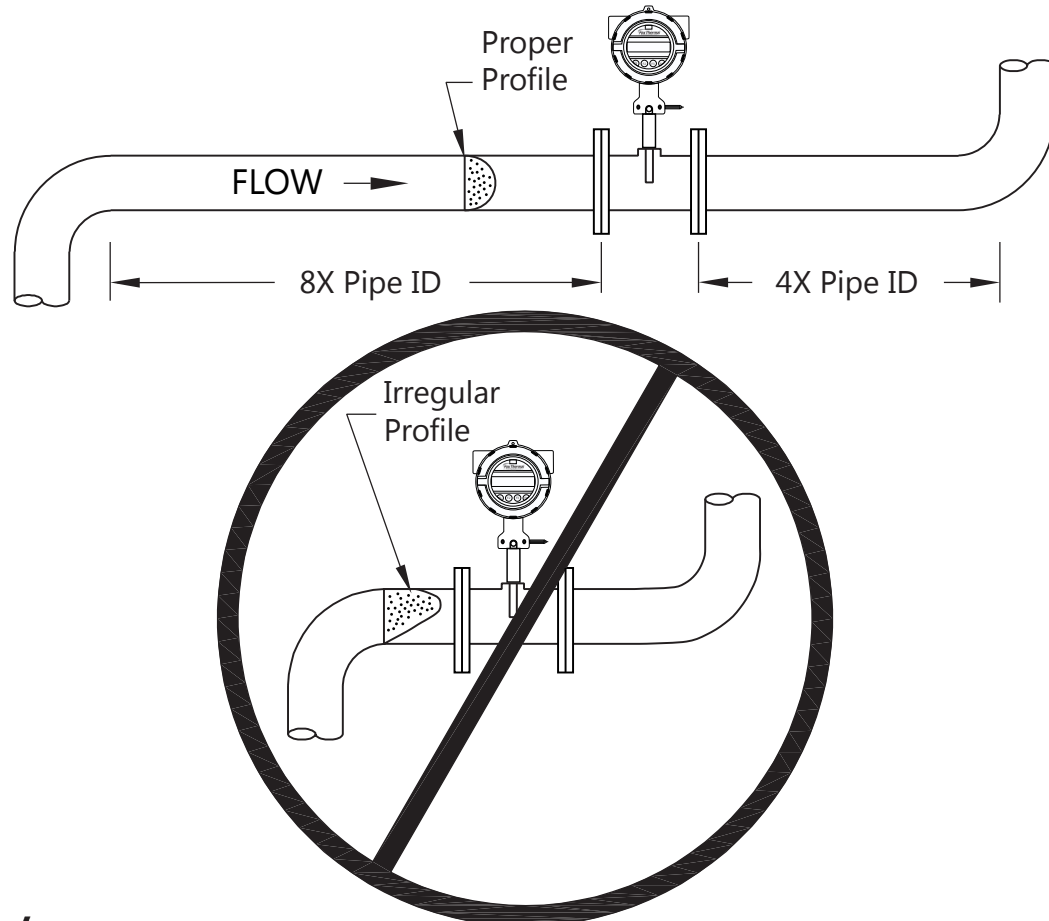

# Installation

## Installation Depth - Insertion Only

The installation depth of the sensor in the pipe is dependent on the pipe size. To get the most accurate reading, proper placement of the sensor window within the pipe is necessary. As shown in Fig 2.4, the end of the sensor window should be 0.73" (18.5 mm) past the center line of the pipe. Review the dimensional drawing below with the following equation to calculate insertion depth:  $L + D/2 + .73" = \text{insertion depth}$

Fig. 2.4: Cross Section of Insertion Sensor Depth in Pipe

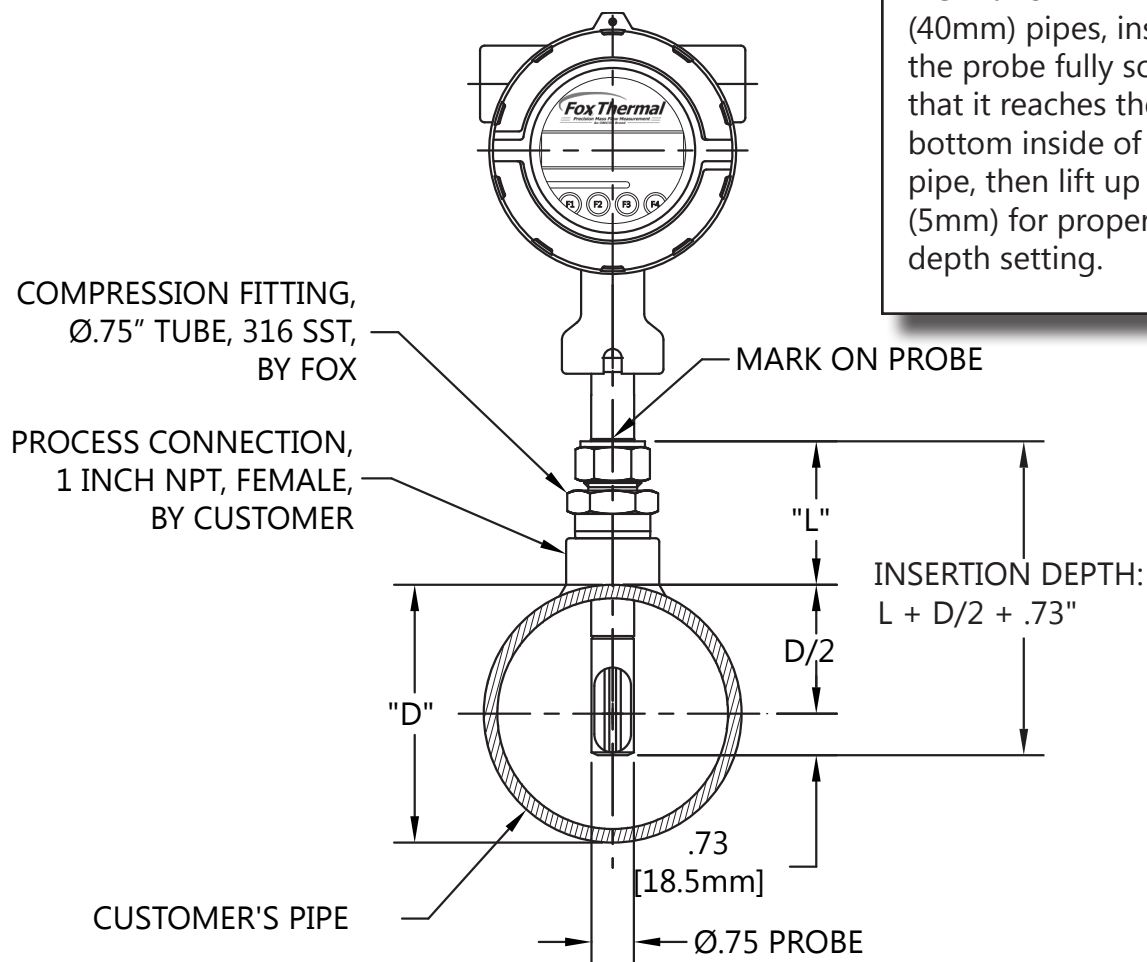

**NOTE!** For 1½" (40mm) pipes, insert the probe fully so that it reaches the bottom inside of the pipe, then lift up 0.2" (5mm) for proper depth setting.

INSTALLATION

## Rotating the Enclosure

The Model FT4A has been designed to allow the enclosure to rotate into four positions for optimal viewing of the display. To rotate the enclosure, first loosen the two set screws near the Flow Direction Indicator. Then unscrew and remove the Flow Direction Indicator to allow the enclosure to swivel into the desired position. Then screw the Flow Direction Indicator back into its place, ensure that it points in the direction of flow, and tighten the set screws. See figure 2.5.

# Installation

## Direction of Flow and Orientation of the Probe Sensor

Both the insertion and inline style flow meters come equipped with a flow direction indicator. Install the meter with the flow direction indicator pointing in the direction of flow in the pipe.

Fig. 2.5: Orientation of Flow Meter

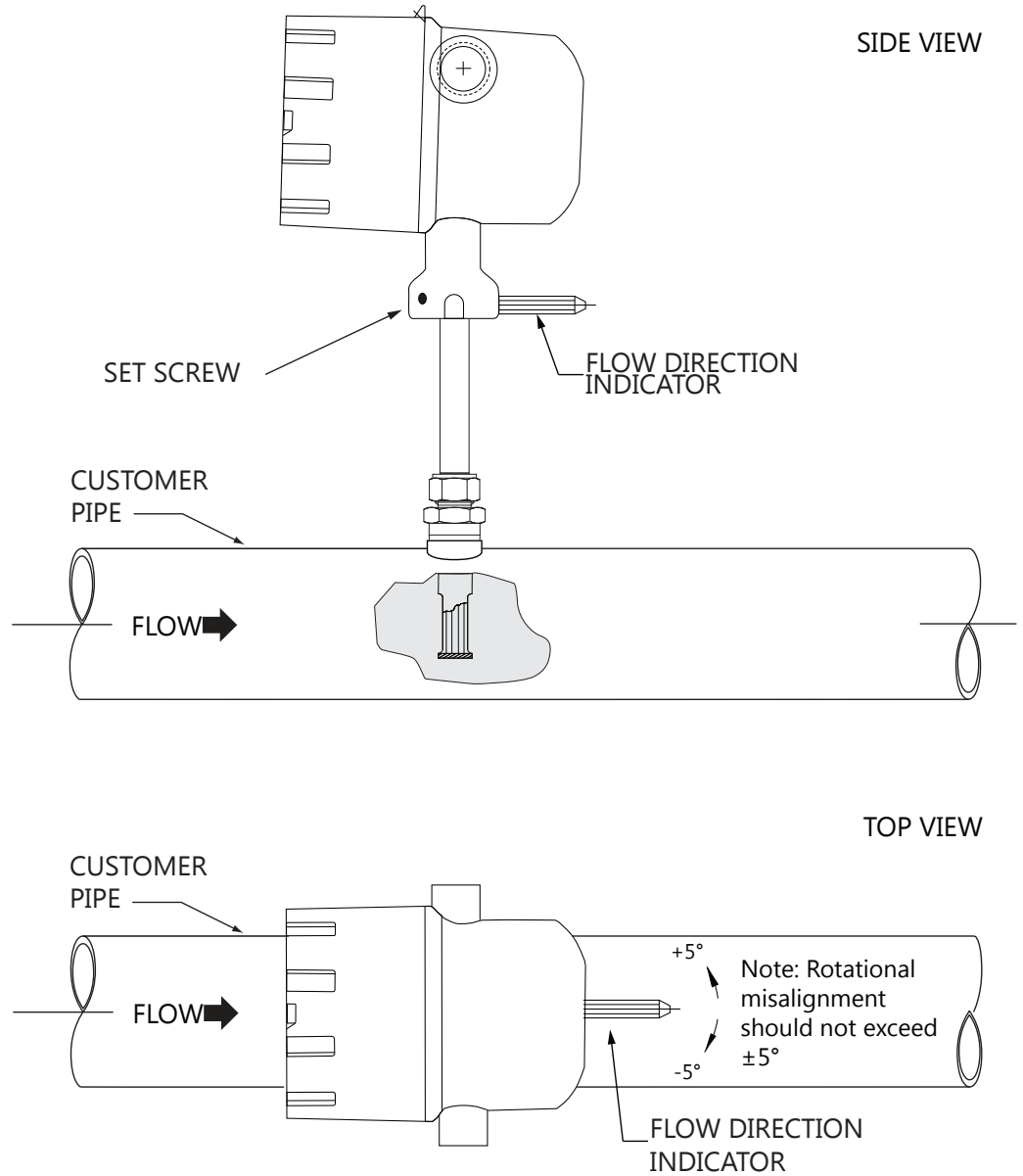

## Installation

### Changing the Orientation of the FT4A Display

The display can be rotated in 90° increments for optimal viewing of the screen. First, open the enclosure by unscrewing the enclosure cap and loosen the two captive phillips screws to open the display assembly. Detach the display board from the metal shield by loosening the three screws on the back of the round shield. Rotate the display board to the desired orientation. Ensure that the display cable is routed flat and straight through the display hinge to prevent binding. Reattach the display board to the metal shield by tightening the three screws. Close the display assembly and secure it to the enclosure with the two captive screws. Finally, install the enclosure cover back on the front of the enclosure.

Fig. 2.6: Accessing Wiring Terminals or Rotating the Display

Loosen these two screws to open the display and access wiring terminals.

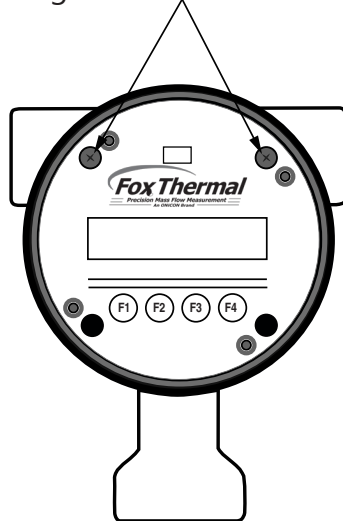

Loosen these three screws to rotate the display in 90° increments ( $\pm 180^\circ$ ).

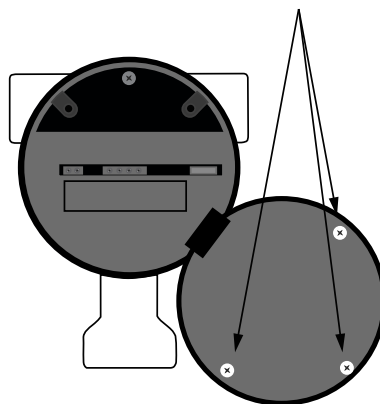

## Installation

### Mounting Instructions - Compression Fittings

The Model FT4A is mounted through a 7/8" hole and a 1" female NPT half coupling provided in the customer's pipe. Insertion style flow meters are not designed for use in pipes smaller than 1½".

- Install the compression fitting into the 1-inch female NPT half coupling.
- When installing in a 2" pipe or larger, install the end of the probe 0.73" (18.5 mm) past the center line of the pipe and tighten the compression fitting nut (refer to figure 2.4 on p. 21).
- When installing into a 1½" pipe carefully install the probe into the pipe until it touches the opposite wall and pull back 0.2". Tighten the compression fitting nut.
- While holding the fitting body steady, finger tighten the nut. Then, tighten the nut with wrenches an additional one and one-quarter (1 ¼) turn. If beginning at 6 o'clock, the wrench would make one full turn back to 6 o'clock and rest at the 9 o'clock position for proper compression. See Figure 2.7.

Fig. 2.7: Proper Tightening of the Compression Fitting Nut

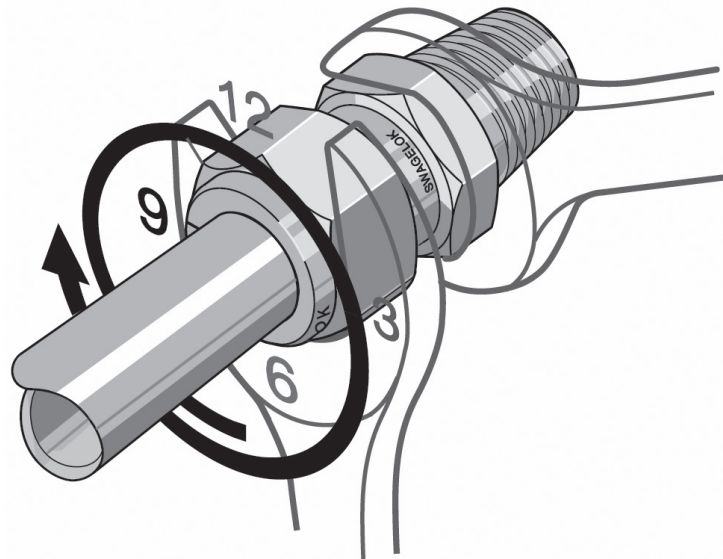

**CAUTION!** Do not tighten compression fitting without .2" distance from wall or damage to probe will occur.



**CAUTION!** Once the compression fitting ferrule is locked onto the probe, the probe can be removed or rotated, but the insertion depth is locked in place.



**CAUTION!** If the stainless steel or teflon ferrules are not properly tightened, and/or the recommended pressure is exceeded, the ferrules can slip on the stainless steel tubing causing damage to the meter or bodily harm.



# Installation

## Installation of a New Retractor Assembly



**NOTE!** For instructions on how to properly weld the NPT female fitting onto pipe, please refer to Document #107590.

1. Remove collar clamp from probe using a 3/16" Hex Key.
2. Remove meter probe from retractor assembly and leave the ball valve open.
3. Install the valve assembly on the pipe, by tightening the Hex Nipple with a 1 3/8" wrench.

Fig. 2.8: Retractor Assembly With and Without Probe Inserted

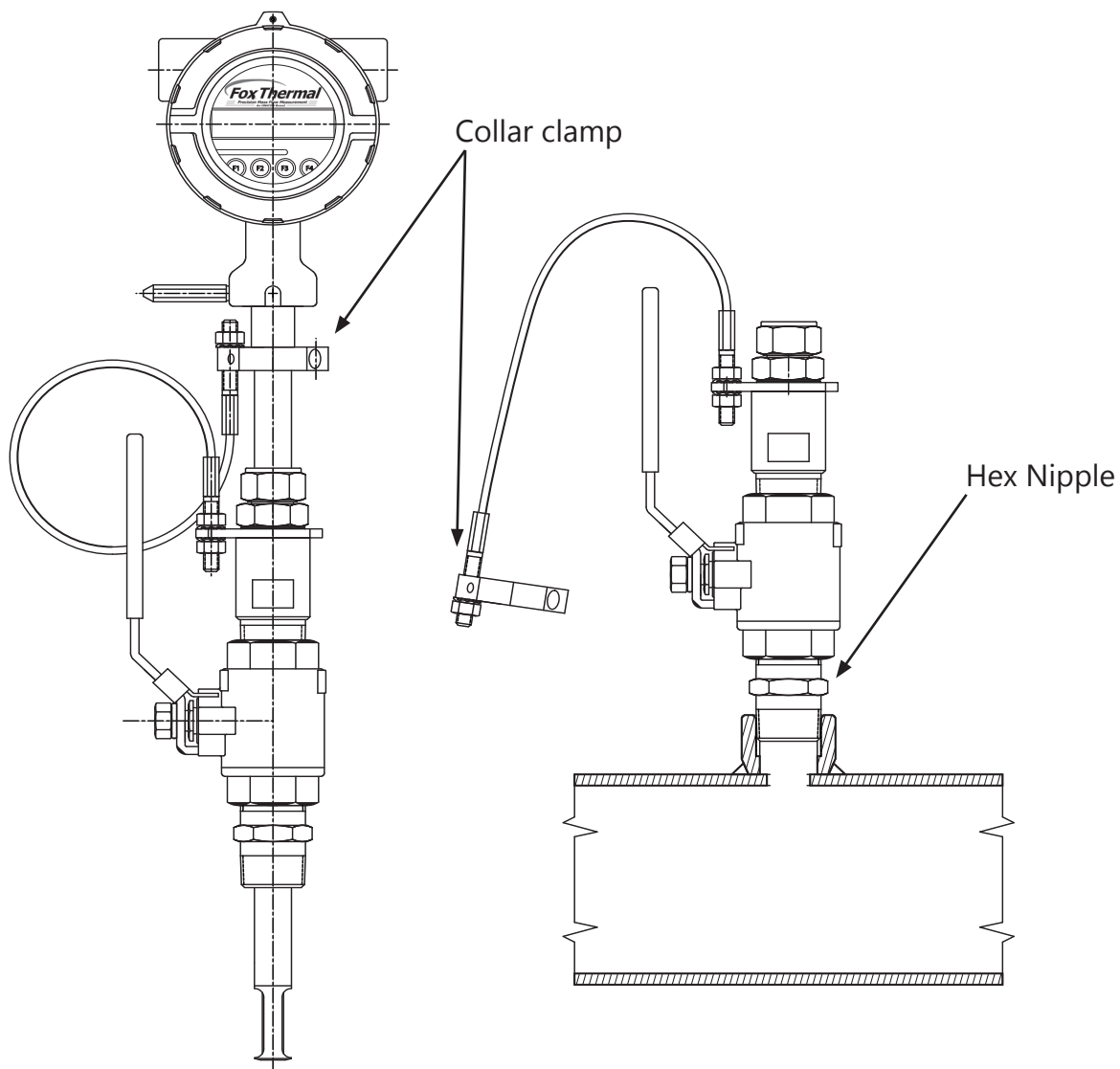

## Installation

4. Insert probe into retractor assembly and pipe to verify that the probe will fit through without obstructions. Carefully slide the probe through the retractor assembly and through the hole to see if there is interference by touching the pipe wall on the far side or until the probe cannot go deeper. Remove the retractor and rework the hole, if required.

Fig. 2.9: Verify Probe Insertion

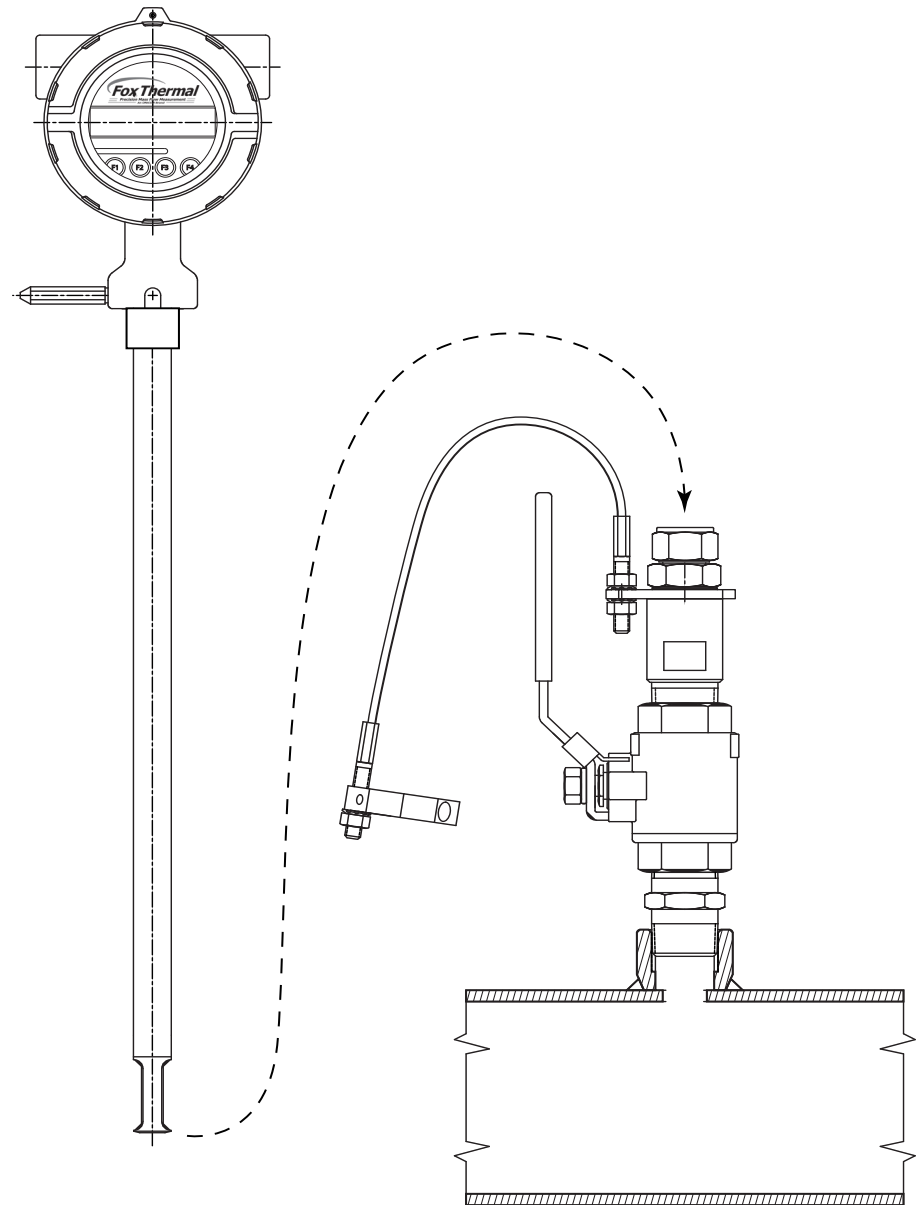

5. Remove probe from retractor assembly again.

# Installation

6. Using the equation ( $L + D/2 + 0.73$ ") from Figure 2.10, calculate the insertion depth and mark on the probe while measuring from the end of the probe.
7. Ensure there is enough clearance to remove the meter from the retractor. See the Retractor Clearance table in Fig 2.10 for the model code of your meter.

Fig. 2.10: Determining and Marking Insertion Depth

RETRACTOR CLEARANCE	
CODE	"RC" DIMENSION
15R	23.5" [59.7 CM]
18R	26.5" [67.3 CM]
24R	32.5" [82.6 CM]
30R	38.5" [97.8 CM]
36R	44.5" [113.0 CM]

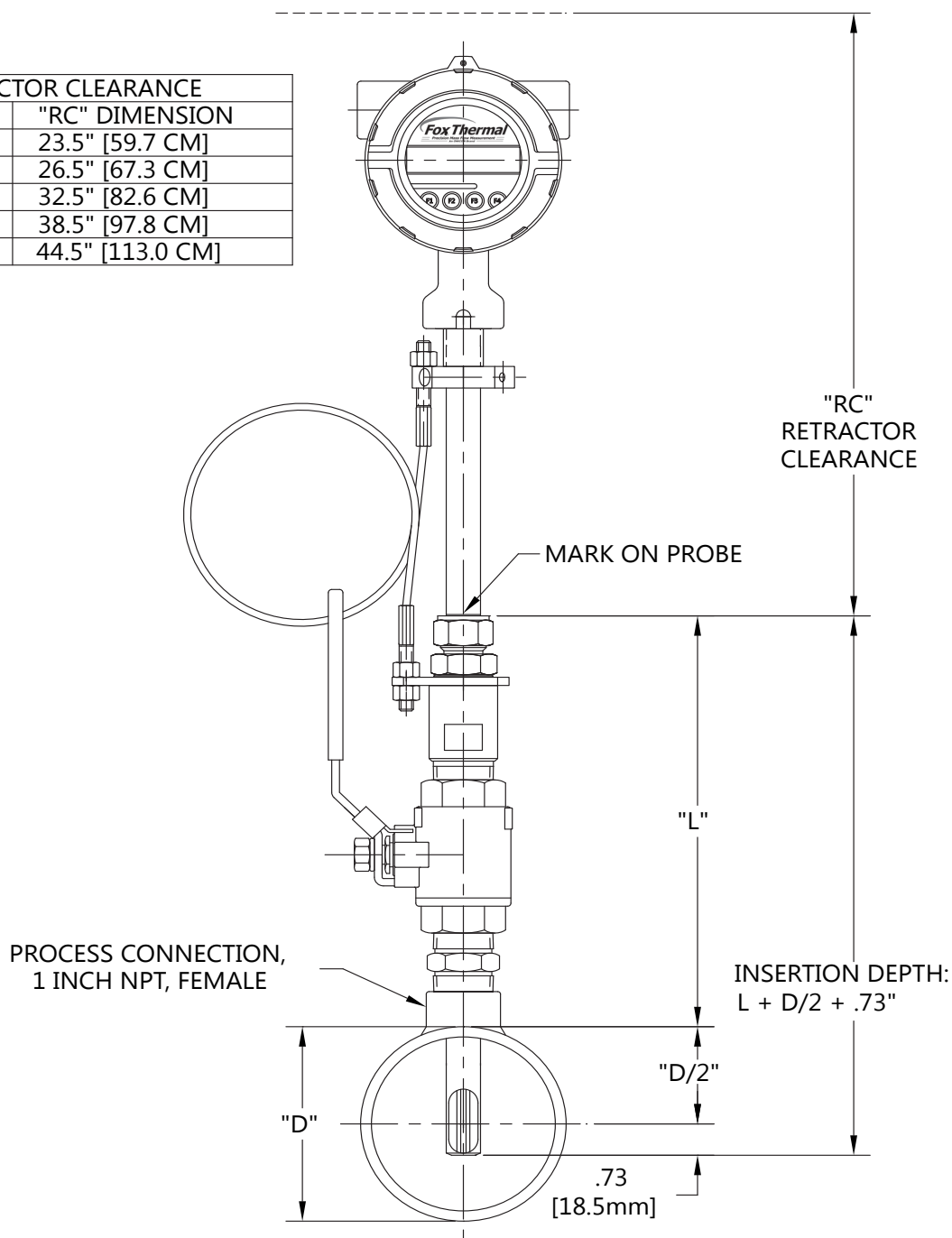

**INSTALLATION**

## Installation

8. Insert probe back into valve assembly to the depth mark and hand-tighten the compression fitting. Make sure collar spacer is in place.
9. Verify that flow direction indicator is in line with pipe and in the direction of flow.

Fig. 2.11: Final Installation of Retractor

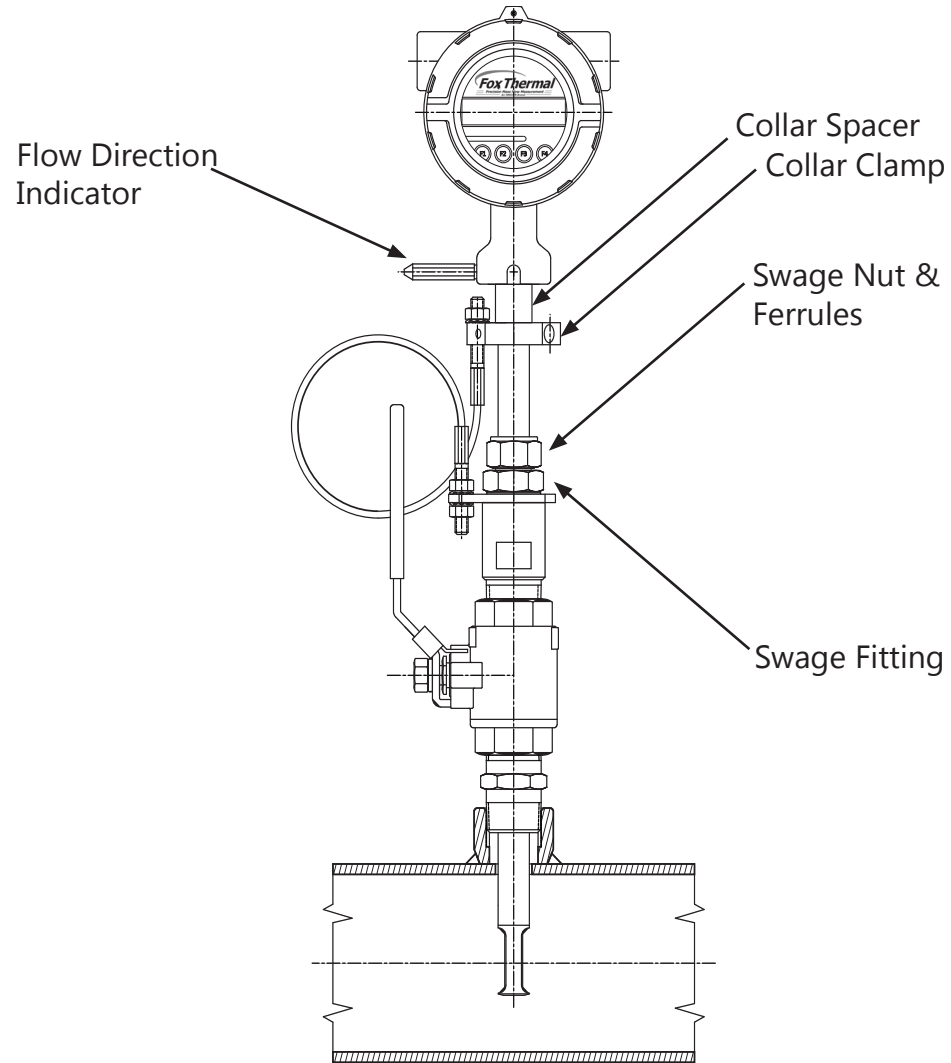

10. Fully tighten compression fitting (refer to "Fig. 2.7: Proper Tightening of the Compression Fitting Nut" on page 24).
11. Install collar clamp back on probe just below the collar spacer. Install collar so that the cable mounting hole is in line with the mounting hole on the bracket (see image in "Fig. 2.8: Retractor Assembly With and Without Probe Inserted" on page 25).



**NOTE!** For instructions on how to properly remove and replace the meter from a retractor, please refer to "Instructions for Removing and Inserting the Meter from a Pressurized Pipe using the Retractor" on page 80.



# Wiring

## Wiring Instructions

To wire the FT4A, unscrew and remove the enclosure cap. Loosen the two captive screws on the display assembly and rotate it open to access the wiring terminals. Connect the power and signal wires to the terminal blocks according to the label and instructions on the following pages.

Cut all wires as short as allowable for a minimum service loop. Obtain the correct length for the FT4A wires using one of these methods:

- Trim the wires to extend 2 inches out of the enclosure after the conduit and wires are routed to the FT4A.
- Trim the wires to extend 5 inches from the end of the conduit before attaching them to the FT4A.

## Wiring Precautions



### WARNING!

- Do not open the enclosure when energized or an explosive atmosphere is present.
- Connect earth ground to a chassis ground screw on the inside or outside of FT4A enclosure to reduce the potential of an electrostatic charging hazard.
- All plumbing and electrical installations of flow meters must be in compliance with local codes, the end user's best engineering practices, and manufacturer's recommendations.
- Do not install the FT4A enclosure near an igniter, igniter-controller or switching equipment to eliminate the possibility of noise interference.
- Do not install an external power supply in a cabinet containing an igniter controller or switching equipment.
- This flow meter contains components that can be damaged by static electricity. You must discharge yourself by touching a grounded steel pipe or other grounded metal prior to working inside this flow meter.
- Close any unused conduit entries using suitably certified plugs

## Power Wiring

For wiring the 12 to 28VDC power, use stranded copper wire, no larger than 16-gauge. Twisted pair shielded cable is required. Supply connection wiring must be rated for at least 90°C.

## Grounding

The enclosure must be properly grounded with a quality earth ground. 16 gauge, stranded wire is required.

## Signal Wiring

For signal and serial communication wiring, the recommended wire gauge is 18 to 22 AWG. Always use twisted pair shielded cable.



## Wiring

### Power Input Requirements: 12 to 28VDC Supply

External DC power supply must provide 12 to 28VDC (10 to 30VDC full input power range) at 6 Watts minimum.

(With 12VDC power, the FT4A can use up to 500mA. With 24VDC power, the FT4A can use up to 250mA.)

A 20 Watt or greater power supply is recommended to ensure it can provide enough current under all temperature, ventilation and power on conditions.

The enclosure must be properly grounded with a quality earth ground. Sixteen (16) gauge, stranded wire, is required for power and earth ground.

Fig. 3.1: Connections for 12 to 28VDC Supply

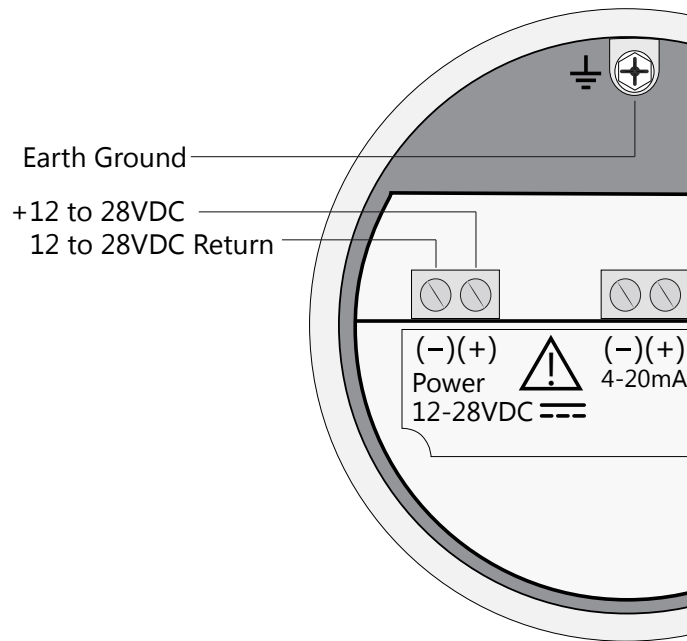

### CAUTION!

- Supply connection wiring must be rated for at least 90°C.

# Wiring



## 4-20mA Output Wiring: Customer-Supplied Power Source

Bring the 4-20mA wiring in through either conduit hub. Connect 4-20mA wiring as shown in the diagram below.

Fig. 3.2: 4-20mA Output Wiring for Customer-Supplied Power Source

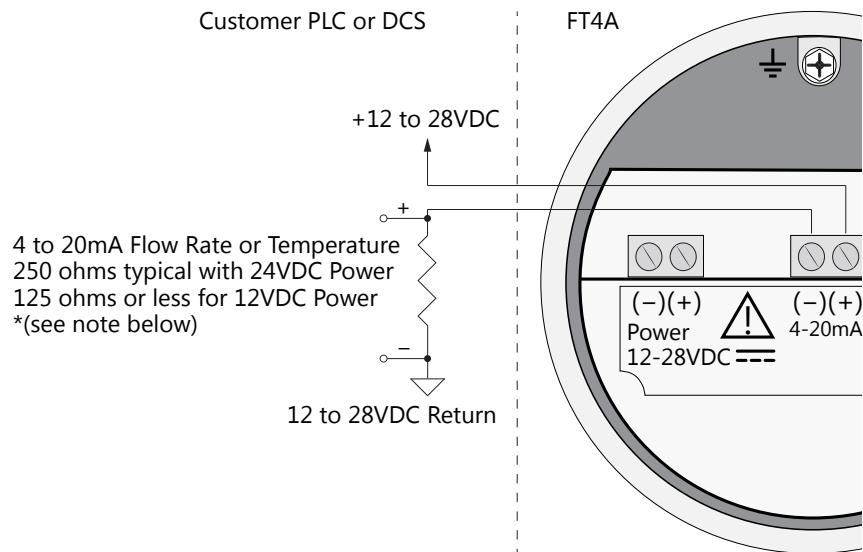

### NOTE!

- When using a 12 volt power supply, the load resistor on the 4-20mA output must be 125 ohms or less to operate properly.
- When using 24 volt power, the load resistor is typically 250 ohms. A 250 ohm resistor in the 4-20mA circuit will result in a 1 to 5 volt signal to the PLC or DCS.
- When using a 24 volt power supply, the load resistor on the 4-20mA output must be 600 ohms or less.
- Some PLC and DCS equipment have built in load resistors, please refer to the technical manuals of such equipment.



## Wiring

### 4-20mA Output Wiring: Loop Power Provided by FT4A

Bring the 4-20mA wiring in through either conduit hub. Connect the 4-20mA as shown in the diagram below.

Fig. 3.3: 4-20mA Output Wiring for Loop Power Provided by FT4A

WIRING

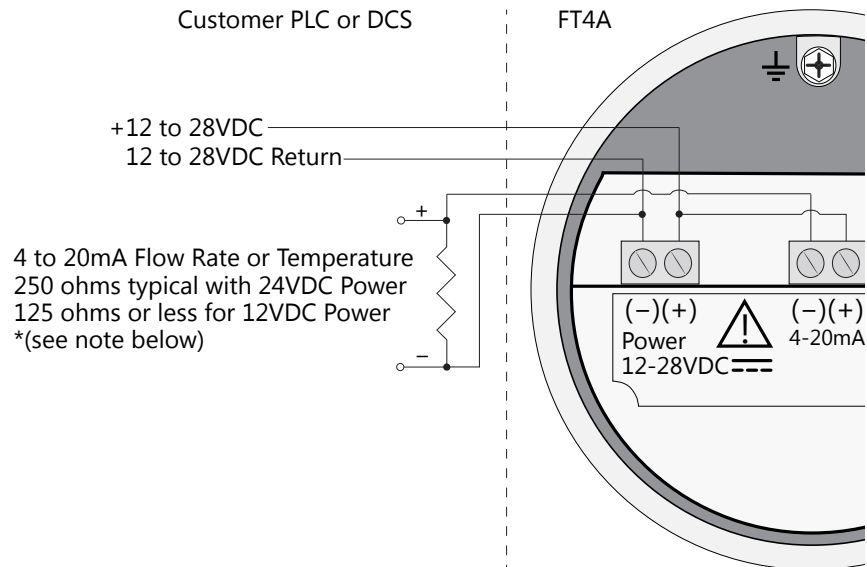

#### NOTES!

- When using a 12 volt power supply, the load resistor on the 4-20mA output must be 125 ohms or less to operate properly.
- When using 24 volt power, the load resistor is typically 250 ohms. A 250 ohm resistor in the 4-20mA circuit will result in a 1 to 5 volt signal to the PLC or DCS.
- When using a 24 volt power supply, the load resistor on the 4-20mA output must be 600 ohms or less.
- Some PLC and DCS equipment have built in load resistors, please refer to the technical manuals of such equipment.



## Wiring



### Pulse/Alarm Output Wiring: Customer Supplied Power Source (Recommended)

Bring pulse/alarm wiring in through either conduit hub. Connect as shown in the diagram below. The pulse/alarm output is an open collector circuit capable of sinking a maximum of 20mA of current. Pulse or alarm selection is programmed using the display or FT4A View™. Only one option, pulse or alarm, can be active at a time.

Fig. 3.4: Pulse/Alarm Output Isolated (Recommended)

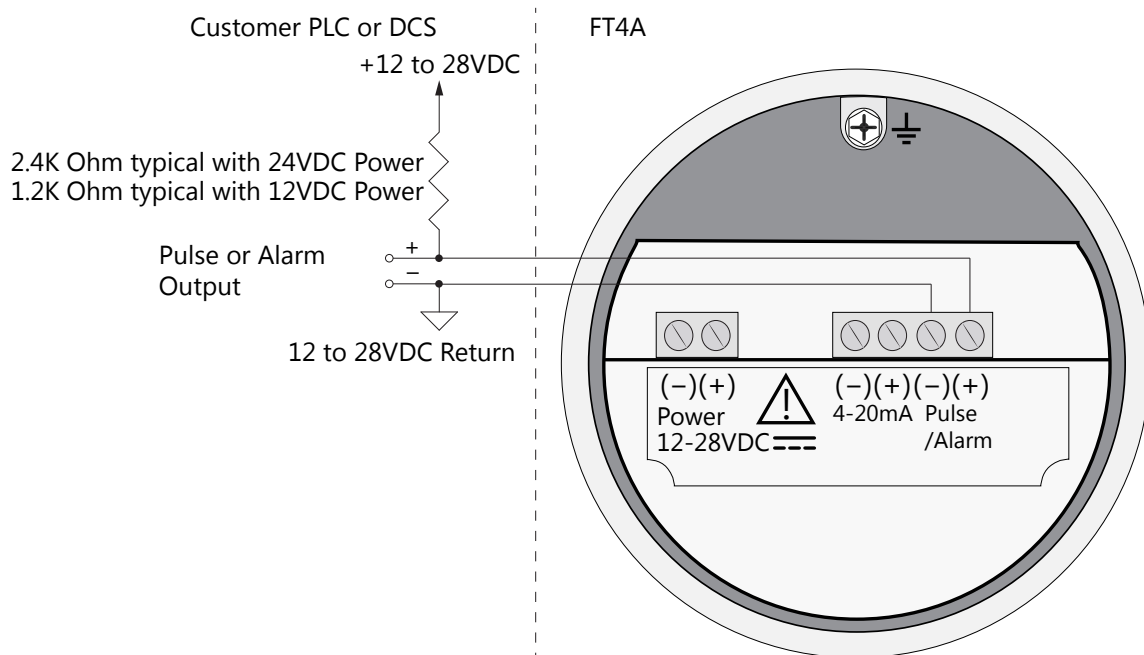

#### NOTE!

- The FT4A Pulse/Alarm output is typically used to drive digital circuitry or solid-state relays. The output of a solid state relay may, in turn, operate loads such as electromechanical relays or alarm indicators.
- The maximum load current of the Pulse/Alarm output is 20mA. Choose a load resistance that provides approximately 20mA with the power supply operating voltage.
- When the output is configured for Alarm and an alarm is not active, the output will be on (0 volts output). When an alarm is active, the output will be off (12 to 28 volts output).
- In order to use the Pulse/Alarm feature on the Model FT4A, this feature must be chosen when the meter is ordered from the factory. Pulse output not available with meters ordered with RS485 Modbus RTU.



## Wiring

### Pulse/Alarm Output Wiring: Power Provided by FT4A

Bring pulse/alarm wiring in through either conduit hub. Connect as shown in the diagram below. The pulse/alarm output is an open collector circuit capable of sinking a maximum of 20mA of current. Pulse or alarm selection is programmed using the display or FT4A View™. Only one option, pulse or alarm, can be active at a time.

Fig. 3.5: Pulse/Alarm Output Power Provided by FT4A

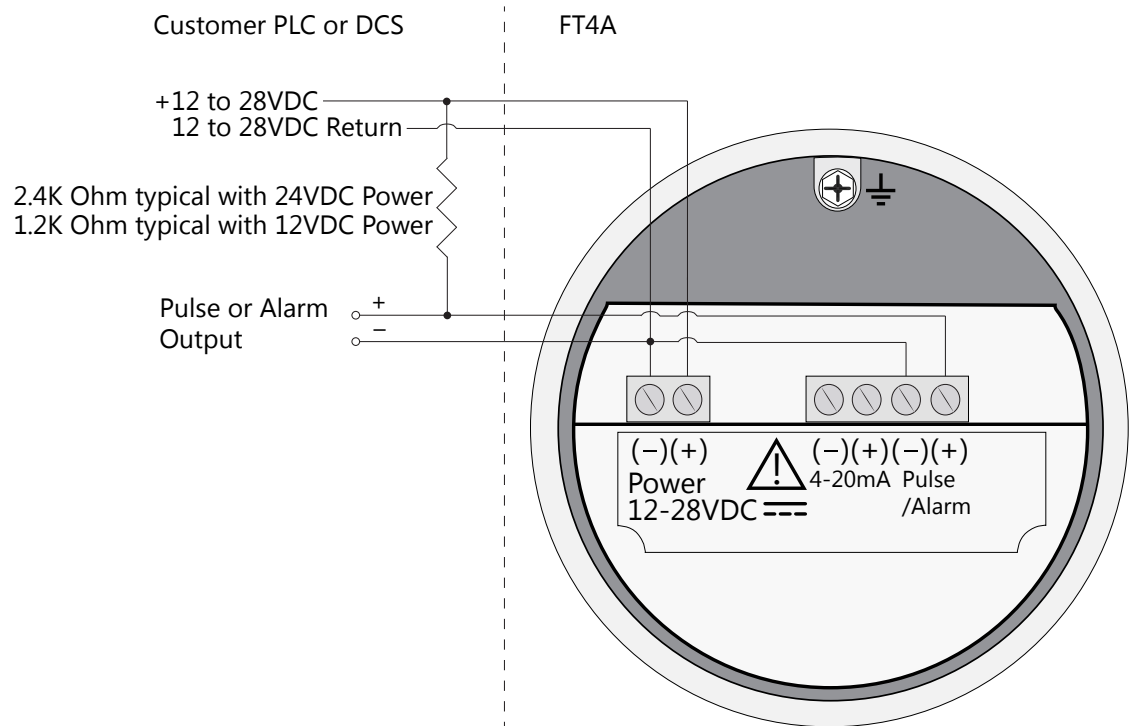

WIRING



#### NOTE!

- The FT4A Pulse/Alarm output is typically used to drive digital circuitry or solid-state relays. The output of a solid state relay may, in turn, operate loads such as electromechanical relays or alarm indicators.
- The maximum load current of the Pulse/Alarm output is 20mA. Choose a load resistance that provides approximately 20mA with the power supply operating voltage.
- When the output is configured for Alarm and an alarm is not active, the output will be on (0 volts output). When an alarm is active, the output will be off (12 to 28 volts output).
- In order to use the Pulse/Alarm feature on the Model FT4A, this feature must be chosen when the meter is ordered from the factory. Pulse output not available with meters ordered with RS485 Modbus RTU.

# Wiring



## RS485 Wiring for RS485 Modbus RTU

Wiring connections are made as shown in the diagram below for Modbus communication. The cable shield should be connected to chassis or earth ground near the Modbus modem.

### Termination Resistor

Connect a termination resistor across the receive/transmit signals of the last device on the communication line. To connect the 121 ohm termination resistor on the FT4A, set jumper W1 to the Terminated position, see Fig 3.6.

Disconnect the termination resistor on all other external RS485 devices. The termination resistor of the FT4A is disconnected by setting jumper W1 to the Open position.

Fig. 3.6: RS485 Wiring

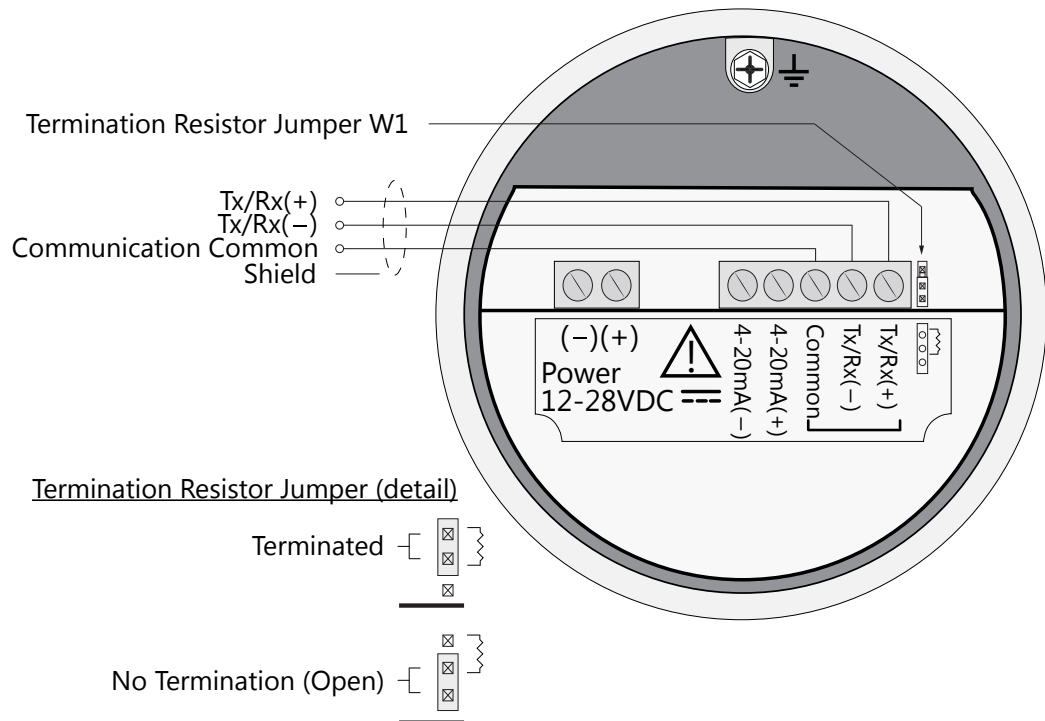

### NOTE!

- In order to use the RS485 feature on the Model FT4A, this feature must be chosen when the meter is ordered from the factory. Modbus RTU is not available with meters ordered with the Pulse/Alarm option.
- W1 jumper will either be in the open or terminated position. It should be in the terminated position on the last meter in the series.

## Wiring

### HART Wiring

The HART connections are made as shown in the diagram below.

### HART 4-20mA Output Wiring: Customer-Supplied Power Source

The 4-20mA current loop and HART modem connections are made as shown in the diagram below.

Fig. 3.7: HART Wiring, Customer-Supplied Power Source

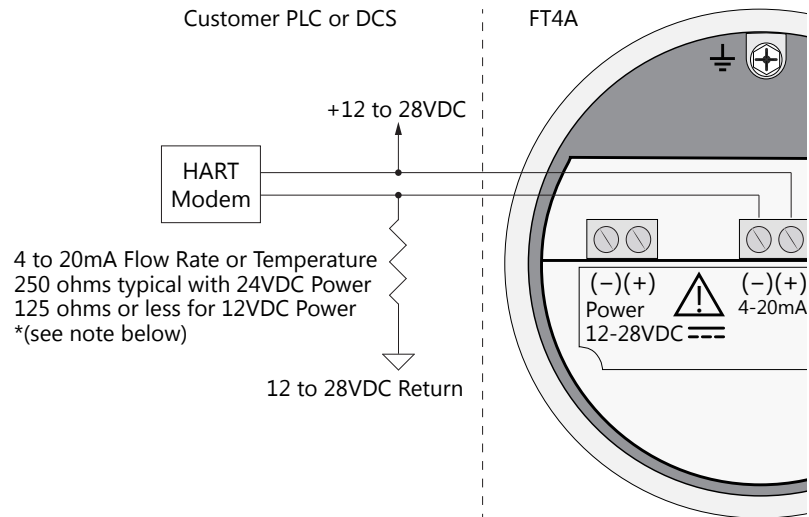

#### NOTE! (Fig. 3.7, 3.8, & 3.9)

- When using a 12 volt power supply, the load resistor on the 4-20mA output must be 125 ohms or less to operate properly.
- When using 24 volt power, the load resistor is typically 250 ohms. A 250 ohm resistor in the 4-20mA circuit will result in a 1 to 5 volt signal to the PLC or DCS.
- When using a 24 volt power supply, the load resistor on the 4-20mA output must be 600 ohms or less.
- Some PLC and DCS equipment have built in load resistors, please refer to the PLC/DCS technical manual.

# Wiring

## HART 4-20mA Output Wiring: Handheld Communicator

The 4-20mA current loop connections are made as shown in the diagram below.

A handheld HART communicator can be connected to test points TP12 (+) and TP13 (-) with clip leads or to the 4-20mA terminal block.

Fig. 3.8: HART 4-20mA Output Wiring, Handheld Communicator

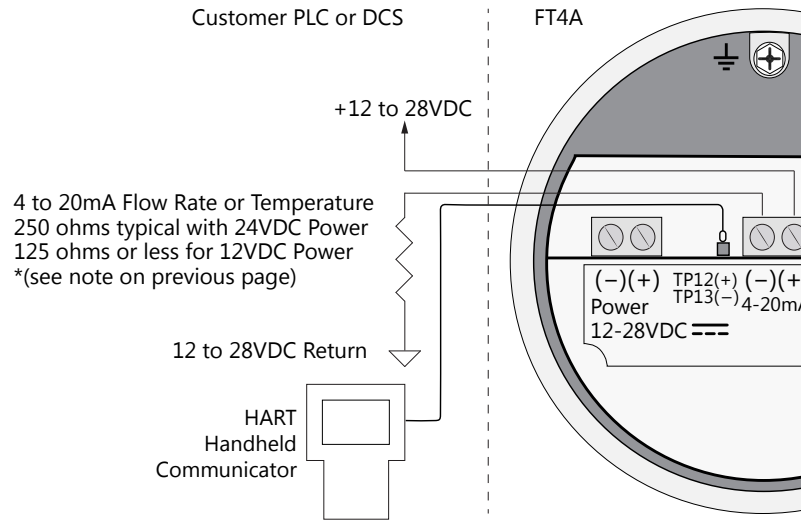

## HART 4-20mA Output Wiring: Loop Power Provided by FT4A

The 4-20mA current loop and HART modem connections are made as shown in the diagram below.

Fig. 3.9: HART 4-20mA Output Wiring, Loop Power Provided by FT4A

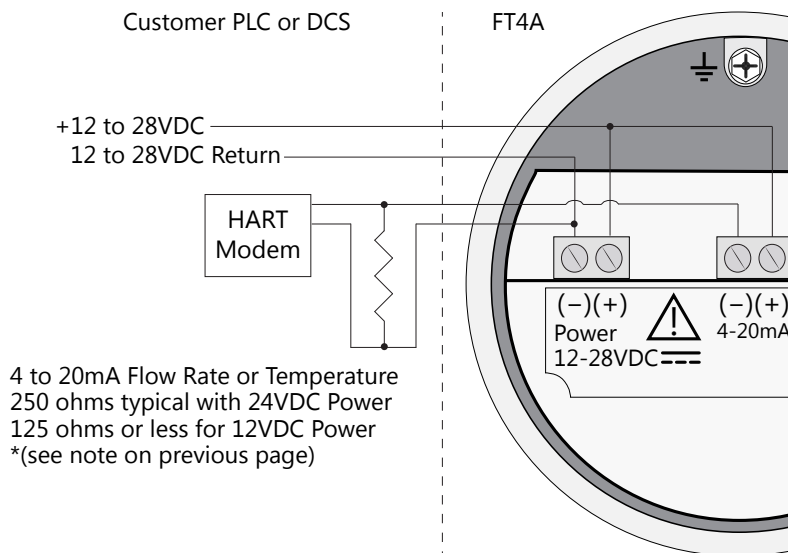

WIRING

## Operation

### Start Up Sequence

The program automatically enters the Run/Measure mode after power up. The screen will show the software version of the FT4A during power up.

### USB Interface

The USB interface is a standard feature which allows communication with a PC to monitor readings and configure settings. FT4A View™, is a free application program from Fox Thermal that connects to the USB interface and allows data monitoring, configuration setting, data logging to Excel, and an option to save and recall FT4A configuration data.

### FT4A Display and Configuration Panel

The FT4A has a 2 line x 16 character display with 4 mechanical buttons. The meter can be programmed by using the display and configuration panel. The configuration panel can be accessed by removing the FT4A cap. Be sure to replace the cap after you are done configuring the FT4A.

Fig. 4.1: FT4A Display and Configuration Panel

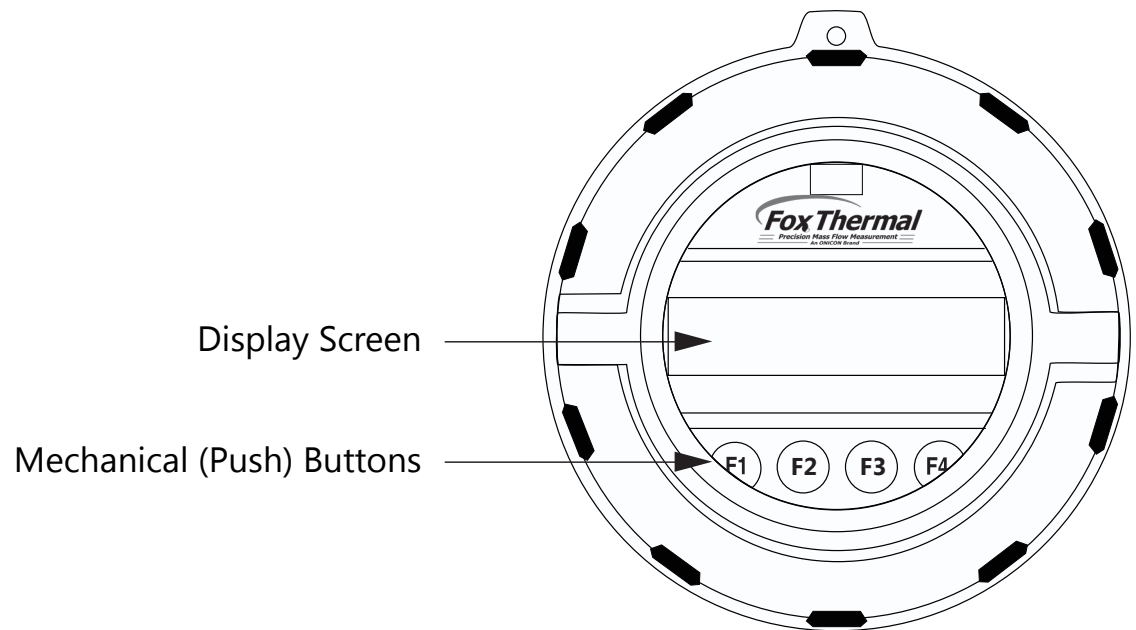

# Operation

## Measurement Mode Display Screens

In the measurement mode, there are four different display screens (display 1, 2, 3 and a prompt screen to enter the programming mode). Two display screens are user programmable (refer to Display Setup p. 46). Scrolling through the display is accomplished by pressing the F1 or F2 key to view the next or previous screen.

## Logs

Pressing the F1 and F2 keys at the same time enters the Logs. Key F4 is used to exit to Display screen #1.

## Reset Total Screen

Pressing the F3 and F4 keys at the same time brings up the Reset Total screen (see p. 56) prompt.

Fig. 4.2: FT4A Measurement Mode Display Screen Navigation

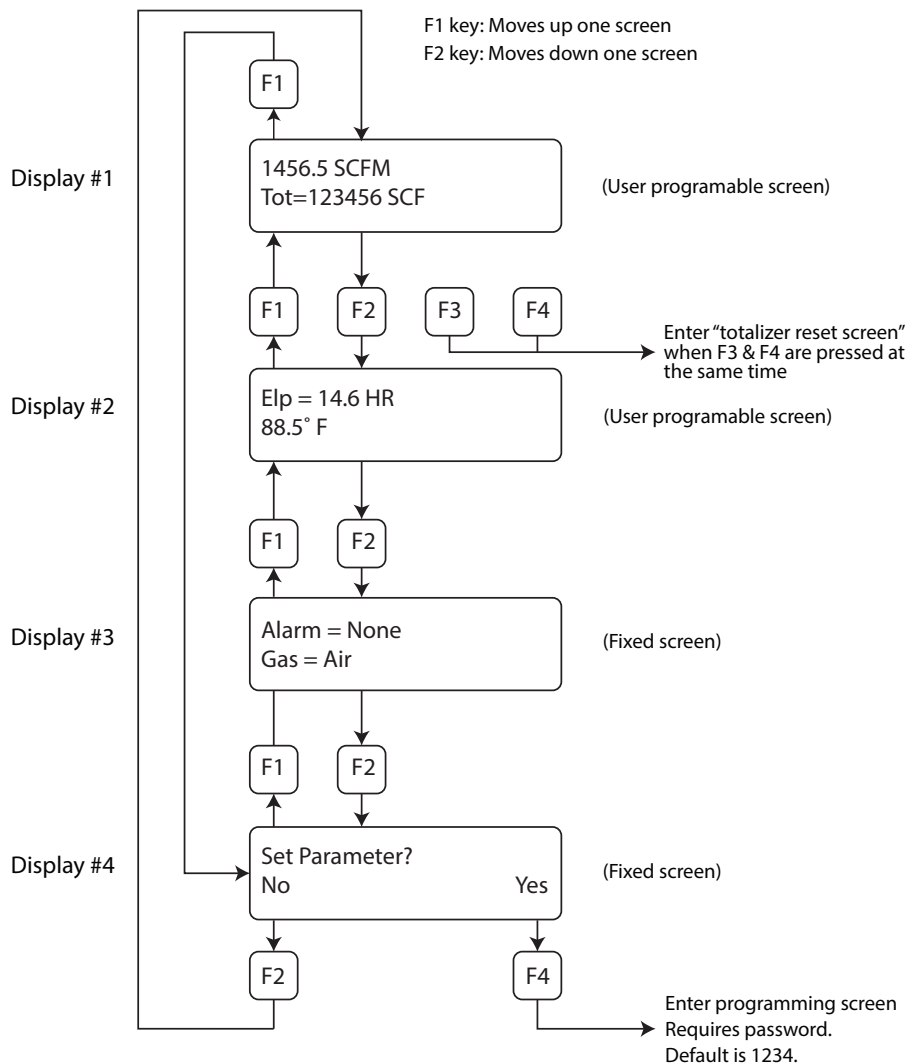

## Operation

### Data Entry using the Display and Configuration Panel

There are 2 basic types of menu entries: one for changing value or string and one for selecting from a selection list.

#### To Change a Value or String :

VALUE = 0.91234	
CHG	OK



Press **CHG (F1)** key to change the value, **OK (F4)** to accept the value.

VALUE = 0.91234			
UP	DN	NXT	OK



Press the **UP (F1)** or **DN (F2)** key to select a new digit or character, the cursor points to the selected digit. Press **NXT (F3)** to select the next digit and **OK (F4)** to accept the entry.

#### To Select from a List:

FLO UNT = SCFM	
NXT	OK



Press **NXT (F1)** key repeatedly until the correct selection is made and **OK (F4)** key to accept the entry.

### Entering the Programming Mode

To enter the programming mode and access the Main Menu, press the **F1** or **F2** key in the normal running mode until the following screen is shown:

SET PARAMETER ?	
No	Yes



Press **YES (F4)** and the following screen will prompt user to enter password:

PASWD: _			
UP	DN	NXT	OK



Enter the correct password, then follow the instructions for changing a value as specified on page p. 40. The default Level 1 password is "1234".



## Operation

If the wrong password is entered, the message "Wrong Password" will display and then return to the programming entry screen.

### Main Menu

If the password is accepted, the Main Menu screen will be shown:

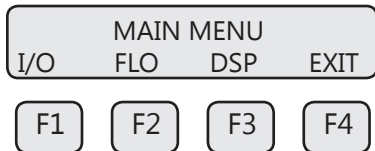

This is the Main Menu screen for the programming mode.

Press **EXIT (F4)** repeatedly until "Normal Mode" is seen briefly to exit the programming mode.

### Analog 4-20mA Output

The following menu allows the scaling of the analog 4-20mA output.

From the Main Menu, press **I/O (F1)** to move to the 4-20mA output selection.

In this screen press **420 (F3)** (screen appearance may vary according to options).

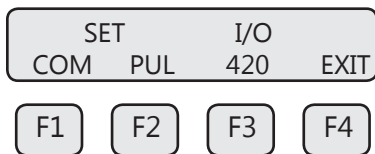

The 4-20mA output is programmable for flow or temperature:



Selections for the 4-20mA output are:

- Flow
- Temp

Select **NXT (F1)** to select Flow or Temperature and then press **OK (F4)**.

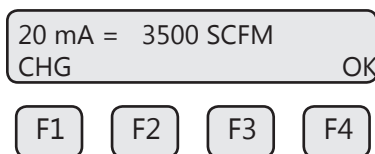

Enter the value for the 20mA and press **OK (F4)** key to accept the setting.

## Operation

Then the following screen will display:

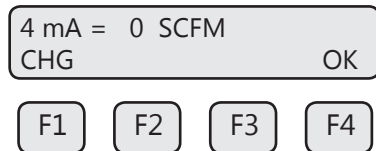

Enter the value for the 4mA and press **OK (F4)**.



**NOTE!** When the flow rate exceeds the programmed value for the 20mA set point, the analog output will stay at 20mA and an alarm code will be generated.



**NOTE!** 4mA is normally set to 0.

This menu allows the user to select an alarm fault level on the 4-20mA output. The alarm is activated when a serious issue is detected preventing the calculation of the correct flow rate. The 3.6mA and 21mA alarm outputs are related to the NAMUR NE 43 alarm feature.

The options are:

- mA Fault=3.6 mA (Force the 4-20mA signal to 3.6mA on alarm)
- mA Fault=21 mA (Force the 4-20mA signal to 21mA on alarm)
- mA Fault=Not use (4-20mA signal alarm fault not used)

After setting the 4mA output value, choose the mA fault value:

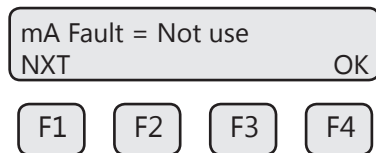

The following events will set the output to 3.6mA or 21mA if the alarm level is selected:

- Sensor resistance above high limit
- Bridge Shutdown

Fig. 4.3: Range of 4-20mA Output and NAMUR Alarm

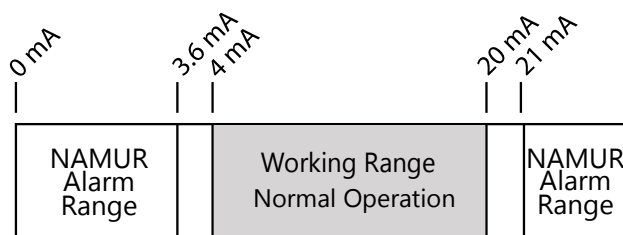

Press **(F4)** repeatedly until "Normal Mode" is seen briefly to exit the programming mode.

## Operation



**NOTE!** When the flow rate exceeds the programmed value for the 20mA set point, the analog output will stay at 20mA and an alarm code will be generated.

### Pulse/alarm Output

If the Pulse/alarm feature was purchased as the second output for the Model FT4A, it can be accessed from the main menu, press **I/O (F1)** (screen appearance may vary).

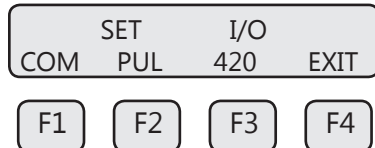

Press **PUL (F2)** to select the pulse output.

The following screen will show:

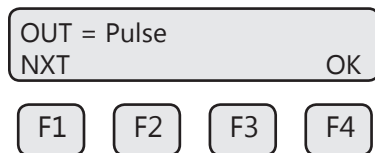

Press **NEXT (F1)** to cycle through output options until you have the selection for "OUT=Pulse" and press **OK (F4)**.

The pulse output can be configured in one of three ways:

1. Specifying how many pulses per unit, P/U (i.e., 10 pulses per SCF)
2. Specifying how many flow units total per pulse, U/P (i.e., 0.1 SCF per pulse)
3. Specifying a maximum frequency to a defined maximum value of flow rate

All of these approaches are equivalent.

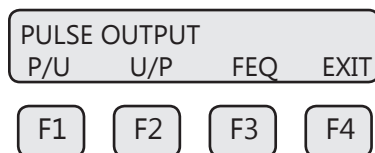

Use **P/U (F1)** to enter pulse per unit, **U/P (F2)** for unit per pulse or **FEQ (F3)** to enter the flow and maximum frequency to scale the pulse/alarm output.



**NOTE!** When data is entered with any of the three described methods, the other values will be re-calculated according to the settings.

## Operation

### Entering data in Pulse per Unit:

From the Pulse/alarm Output Menu above, press **P/U (F1)** and the following screen will show:

PLS/UNT = 2		
CHG		OK

F1   F2   F3   F4

Press **CHG (F1)** to change the setting and then **OK (F4)** to accept entry.

The value entered is in pulse per selected flow unit total (i.e., 2 pulses per SCF).

### Entering data in Unit per Pulse:

From the Pulse/alarm Output Menu above, press **U/P (F2)** and the following screen will show:

UNT/PLS = 0.5		
CHG		OK

F1   F2   F3   F4

Press **CHG (F1)** to change the setting and then **OK (F4)** to accept entry.

The value entered is in unit per pulse (i.e. 0.5 flow unit total per pulse)

### Entering data with flow and maximum frequency:

From the Pulse/alarm Output Menu above, press **FEQ (F3)** and the following screen will show:

MaxFreq=100 Hz		
CHG		OK

F1   F2   F3   F4

Enter the maximum pulse rate (frequency) and press **OK (F4)**.



**CAUTION!** Maximum pulse rate (frequency) cannot exceed 100 Hz.

The next screen will show:

MaxFlo=5000 SCFM		
CHG		OK

F1   F2   F3   F4



**NOTE!** If the flow rate exceeds the maximum pulse rate (frequency), the output will stay at 100 Hz and the FT4A will issue an alarm code.

## Operation

### Alarm Output

If the Pulse/alarm feature was purchased as the second output for the Model FT4A, press **I/O (F1)** key from the Main Menu screen.

The screen will show:

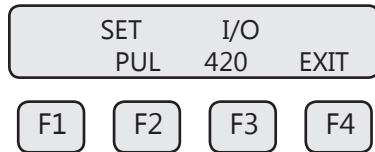

Then press **PUL (F2)** and the screen may show:



Then press **NXT (F1)** to select the correct alarm and press **OK (F4)**.

Selections are:

- Not used
- Pulse
- HiFloAlm = High Flow Alarm
- LoFloAlm = Low Flow Alarm
- HiTempAlm = High Temperature Alarm
- LoTempAlm = Low Temperature Alarm
- System Alarm

When the output is set to Alarm and there is no alarm condition, the output will be on (0 volts). When an alarm is active, the output is turned off (12 to 24 volts).

The following events will activate the system alarm level if it is selected:

- Sensor resistance above high limit
- Bridge Shutdown

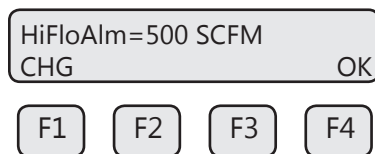

Enter the value for the limit by pressing **CHG (F1)** and then **OK (F4)**.



**NOTE!** There is only one output to operate as a pulse output or an alarm output. Both cannot operate at the same time.

## Operation

### Serial Communication Settings

If RS485 Communication feature was purchased as the second output for the Model FT4A, the Serial communication settings can be programmed by pressing **I/O (F1)** key from the Main Menu. The screen will show:

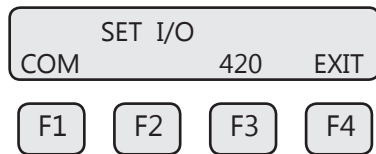

Press **COM (F1)** to select Serial communication. The screen may show:

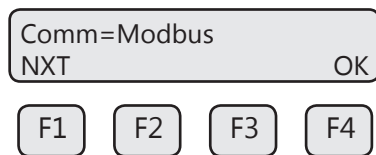

Options for serial communication are:

- None
- MODBUS
- HART



**NOTE!** Any selection other than "None" requires the communication option for the selected communication type. If enabling a communication option, see the Communications Protocols section of this manual.

### Display Setup

There are four display screens that you can cycle through in normal operating mode (see Figure 4.2 on p. 39). Two of the four display screens are fixed and cannot be changed (displays #3 & 4). The other two screens are programmable to show the information that you prefer and are discussed in this section.

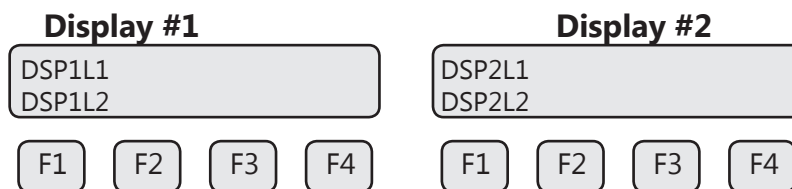

Selections are:

- DSP1L1 Display 1, Line 1
- DSP1L2 Display 1, Line 2
- DSP2L1 Display 2, Line 1
- DSP2L2 Display 2, Line 2

## Operation

### To Program Display Screens #1 & 2:

From the Main Menu press **DSP (F3)** to select the display menu:

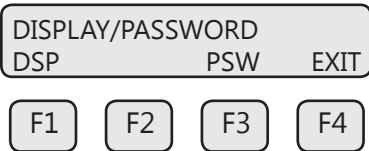

Press **DSP (F1)** key. The display will show:

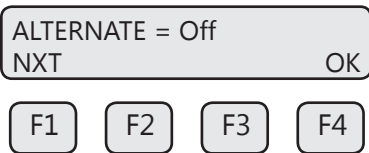

These are the selections for the display #1 line #1.

Selections are:

- Flo rate            Flow rate
- Total                Total mass or volume
- Elps                 Elapsed time
- Temp                Temperature
- Alarm                Error codes

When the selection is correct, press **OK (F4)** to accept. The display will then go through the same process for all 4 lines of the 2 programmable displays (DSP1L1, DSP1L2, DSP2L1 and DSP2L2).

After the last line of display 2 is accepted, the display will show the following menu:

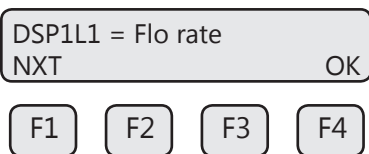

This menu allows you to alternate between menu display 1 and 2 every few seconds.  
Selections are: On or Off

Press **OK (F4)** to accept selection.

Press **EXIT (F4)** repeatedly until "Normal Mode" is seen briefly to exit the programming mode.

## Operation

### Password

There are two user level passwords, only **Level 1** is programmable and gives access to all the normal settings. The second password is used to allow access to calibration factors and should normally never be changed unless advised by the Fox Thermal service department, or to set a new password in the event that the user forgets the **Level 1** password.

Default **Level 1** password is "1234", and **Level 2** password is "9111".

The **Level 1** programmable password can be disabled by setting it to "0".

From the Main Menu press **DSP (F3)** to select the display menu:

### To Program the Password:

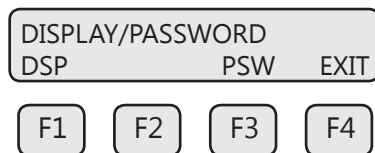

Press **PSW (F3)** key to select password.

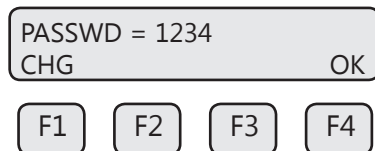

This screen displays the current **Level 1** password.

Press **CHG (F1)** key to change the password and enter new value.

Press **OK (F4)** to accept new data and exit programming by pressing **EXIT (F4)** key repeatedly until out of the programming mode.



**NOTE!** Password can be number or letter characters up to 4 digits.

### Units Settings Menu

This menu is used to set the units for flow, temperature, and pressure. Reference temperature and reference pressure settings can be accessed also.

These values will be set at Fox Thermal using information supplied by the customer. These values can be changed to match a new application. The units setting is accessed from the Main Menu.

To access the Unit Settings Menu:



## Operation

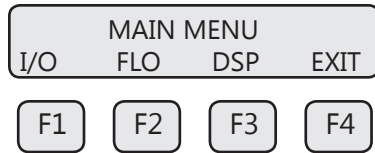

Press **FLO (F2)**:

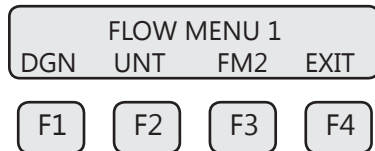

Press **UNT (F2)** for Unit selection.

The screen will show:

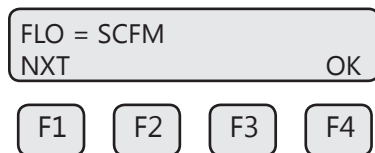

Press **NXT (F1)** to change selection and **OK (F4)** to accept.



**NOTE!** The totalizer (total flow measured) will roll over when reaching a certain value. The maximum value is dependent on the flow units selected (see Totalizer Rollover p. 55).

Selections for flow units are:

SCFM	LBS/M	MSCFD (MCFD)
SCFH	LBS/S	SM3/H
NM3/H	NLPH	MT/H
NM3/M	NLPM	NM3/D
KG/H	MMSCFD (MMCFD)	MMSCFM (MMCFM)
KG/M	LBS/D	SCFD
KG/S	SLPM	MCFD (MSCFD)
LBS/H	NLPS	SM3/M
		SM3/D



### **WARNING!:**

The FT4A re-calculates area, 4 and 20mA values, maximum flow for the pulse output and zero flow cutoff when changing flow units.



**NOTE!** The totalizer values do not adjust or correct for the new units. When changing flow units, log the totals in the totalizer and then reset the totalizer after they've changed flow units to maintain accuracy in the totalizer. After pressing **OK (F4)** to accept the Flow unit the display will prompt for the

## Operation

temperature unit setting:

TMP UNT= Deg F	
NXT	OK

F1   F2   F3   F4

Press **NXT (F1)** to change selection and **OK (F4)** to accept.

Selections for Temperature units are:

- Deg C
- Deg F

After pressing **OK (F4)** to accept the temperature unit setting, the display will prompt for temperature reference in selected unit.

TmpRef = 60 °F	
CHG	OK

F1   F2   F3   F4

Press **CHG (F1)** to change the reference and **OK (F4)** to accept.

After pressing **OK (F4)** to accept the reference temperature, the display will prompt for the reference pressure unit selection:

PRES UNT= Psia	
NXT	OK

F1   F2   F3   F4

Press **NXT (F1)** to select next entry and **OK (F4)** to accept.

Selections are:

- mmHG Millimeters of mercury (absolute)
- Psia Pounds per square inch absolute
- bara Bar absolute

After the pressure unit selection is made, the display will show a menu to enter the reference pressure:

PresRef= 14.7	
CHG	OK

F1   F2   F3   F4

Press **CHG (F1)** to change it and **OK (F4)** to accept.

## Operation

After the reference pressure is accepted, the FT4A will recalculate and display gas density at user's reference temperature and pressure:

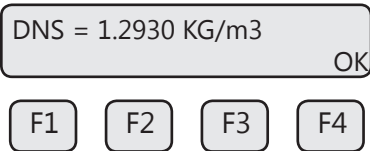

The gas density is for information only. Press **OK (F4)** to continue.

### Flow Parameters

This is the menu used to set various flow parameter values. They are: Flow cutoff, pipe diameter, filter, high and low alarm for flow and temperature.

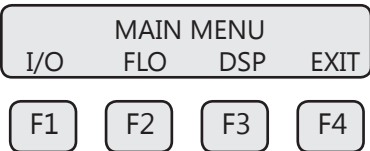

The menu is accessed from the Main Menu by pressing **FLO (F2)**:

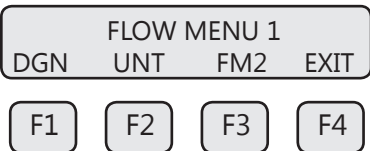

Then press **FM2 (F3)**:

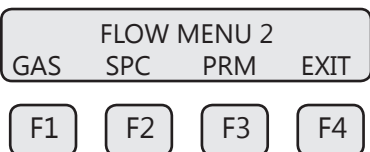

**NOTE!** The **SPC** function key will only appear and be accessible from a **Level 2** password.

Then press **PRM (F3)**.

### Flow Cutoff

The first parameter is Flow Cutoff:

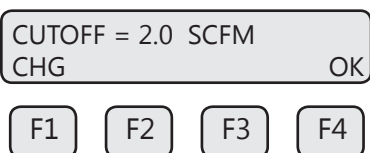

Enter the value for the low flow cutoff and then press **OK (F4)**.

When the flow rate falls below the zero flow cutoff, the flow meter will display a flow value of zero.

## Operation

### Pipe Diameter

To set the Pipe Diameter:

Pipe_id = 3.068 In	OK
CHG	

F1 F2 F3 F4

Enter the pipe diameter in inches or millimeters and then press **OK (F4)**. Use millimeters for metric flow unit selections and inches for English flow unit selections. If the pipe/duct is a square or rectangle, the hydraulic diameter (equivalent value for a round pipe) must be entered for the pipe ID.

### Filter Value

The Filter Value is entered in seconds. The allowable time constant range is 0.8 to 10 seconds. The filter time interval is proportional to the dampening.

Enter the filter value and then press **OK (F4)**.

FILTER = 0.8 sec	OK
CHG	

F1 F2 F3 F4

### High Flow Rate Alarm

To set the parameters for a High Flow Rate Alarm:

HiFloAlm = 1234 SCFM	OK
CHG	

F1 F2 F3 F4

This is the upper flow limit alarm value that can be associated with the alarm output. An alarm code is generated when the flow value exceeds this limit. If no checking is needed, this value should be set to zero.

Press **OK (F4)** to accept the value.

### Low Flow Rate Alarm

To set the parameters for a Low Flow Rate Alarm:

LoFloAlm = 100 SCFM	OK
CHG	

F1 F2 F3 F4

This is the lower flow limit alarm value that can be associated with the alarm output. An alarm code is generated when the flow value is below this limit. If no checking is needed, this value should be set to zero. Press **OK (F4)** to accept the value.

## Operation

### High Temperature Alarm

To set the parameters for a High Temperature Alarm:

HiTmpAlm = 200° F		OK	
CHG			
F1	F2	F3	F4

This is the upper temperature limit alarm value that can be associated with the alarm output. An alarm code is generated when the temperature value exceeds this limit. If no checking is needed, this value should be set to zero.

Press **OK (F4)** to accept the value.

### Low Temperature Alarm

To set the parameters for a Low Temperature Alarm:

LoTmpAlm = 20° F		OK	
CHG			
F1	F2	F3	F4

This is the lower temperature limit alarm value that can be associated with the alarm output. An alarm code is generated when the temperature value is below this limit. If no checking is needed, this value should be set to zero.

Press **OK (F4)** to accept the value.



**NOTE!** If the programming menu was entered with a **Level 2** password, then more menus will be shown concerning factory-set parameters that should not be changed.

### K Factor

The K FACTOR allows the user to adjust the meter's calibration. The Fox Thermal flow meter increases or decreases the measured flow rate by the K Factor. This results in a direct scaling of the meter's output across the entire full range.

The K Factor parameter is accessed from the "Flow Menu 2" menu by entering a **Level 2** password "9111" and pressing the **SPC** key (**F2**).

FLOW MENU 2			
GAS	SPC	PRM	EXIT
F1	F2	F3	F4

The following screen will be displayed:

## Operation

K fact=0%	
CHG	OK

F1   F2   F3   F4

Press **CHG (F1)**. Add the correction factor and press **OK (F4)**.

For Example:

If you want the flow meter to read 5% higher, enter 5.0%.

If you want the flow meter to read 5% lower, enter -5.0%.

If an existing K Factor is present, add the new K Factor to the existing value.

Upon pressing **OK (F4)**, an option to restore the database will follow.

### Restore Database

In case of user error, the ability to restore the meter to the original factory settings can be achieved in this menu. The display will show:

RESTORE DATABASE?	
YES	NO

F1   F2   F3   F4

Press **YES (F1)** ONLY if you want to restore your database to the initial factory setting that the meter was shipped with. All current user-entered settings will be overwritten.

The green LP3 LED will flash at a faster pace until the recall is performed. The "RESET CRC" screen will follow "RESTORE DATABASE". Upon pressing **OK (F4)**, an option to reset the NVRAM CRC will follow.

### Reset CRC

If the NVRAM CRC check fails (Error Code 36), the programmed settings values will need to be verified and corrected before clearing the error. Call Fox Thermal Customer Service if you need assistance.

RESET CRC?	
YES	NO

F1   F2   F3   F4

Press **YES (F1)** ONLY if you want to reset the CRC and generate a new CRC value. Press **OK (F4)** to move on.

## Operation

### Totalizer Rollover

The FT4A has an automatic roll-over function. The total flow count of the FT4A will roll over after the following values:

- Most flow units: 99,999,999,999
- MSCFD: 999,999,999
- MMSCFM: 9,999,999
- MMSCFD: 999,999

### Simulation

This menu allows for simulation of flow rate and temperature. It should only be used for testing and demonstration purposes. **Make sure to return all of these simulation values to zero, before returning to the normal mode of operation.**



**CAUTION!** If the 4-20mA and/or the pulse/alarm outputs are connected to controllers, set the controllers to "manual". This will ensure that the simulated signals do not cause false controller action.

The menu is accessible from the main programming menu by pressing **FLO**, and **DGN (F1)**:

FLOW MENU 1			
DGN	UNT	FM2	EXIT
F1	F2	F3	F4

Pressing **DGN (F1)** will show:

DIAGNOSTIC			
SIM	ZRO	EXIT	
F1	F2	F3	F4

Pressing **SIM (F1)** will show:

Simulate Flow?			
YES	NO		
F1	F2	F3	F4

Press **YES (F1)** to continue.

FloSim = 0 SCFM			
CHG	OK		
F1	F2	F3	F4

Enter the value and then press **OK (F4)**.



**NOTE!** Enter zero to disable this feature.

# Operation

Simulate Temp?	
YES	NO

F1   F2   F3   F4

Press **YES (F1)** to continue.

TmpSim = 0 C	
CHG	OK

F1   F2   F3   F4

Enter the value and then press **OK (F4)**.



**NOTE!** Enter zero to disable this feature.

ENABLE SIM?	
YES	NO

F1   F2   F3   F4

Press **YES (F1)** to start the simulation mode, otherwise press **NO (F4)**. Upon pressing either key, the program will return to the FLOW MENU 1 screen.



**NOTE!** Simulation Mode will be cleared if the power is cycled.

### Reset Total and Elapsed Time

Enter the flow totalizer and elapsed time screen by pressing the **F3** and **F4** keys at the same time in the normal running mode (password required).

RESET TOTAL ?	
NO	YES

F1   F2   F3   F4

Press **YES (F4)** to reset total and elapsed time. Press **NO (F1)** to cancel.



## Operation

### Calibration of the Fox Thermal Model FT4A Thermal Flow Meter

To ensure that all Fox Thermal flow meters meet specified performance parameters and provide accurate, repeatable measurements in the field, all calibrations are performed with NIST-traceable flow standards. Each meter is shipped from the factory with a Fox Thermal Calibration Certificate.

### Calibration Validation

Calibration Validation allows our customers to validate the accuracy and functionality of the meter in the field with a push of a button. By performing a simple test, the operator can verify that the meter is running accurately.

CAL-V<sup>®</sup> ensures the repeatability, functionality of the sensor and its associated signal processing circuitry, and cleanliness of the sensor.

Fox Thermal has developed the CAL-V<sup>®</sup> Calibration Validation to help our customers avoid sending the meter back for annual or biennial re-calibrations.

### CAL-V<sup>®</sup> Calibration Validation Test

This test allows the user to confirm the calibration of the FT4A by verifying the functionality of the sensor and sensor signal processing circuitry. During the CAL-V<sup>™</sup> calibration validation test, the microprocessor adjusts current to the sensor elements and determines the resulting electrical characteristics. Data within established tolerances confirms the meter is accurate. This test can be performed under no flow or normal flow conditions. The test takes up to four minutes to complete. At the conclusion of the test the meter will return to normal measuring mode and a Pass or Fail message will be displayed. Press F4 to terminate the test or to return to the normal display screen after the test is complete.

Press **FLO (F2)** from the main menu. The display will show:

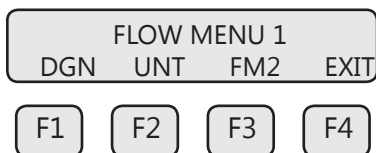

Press **DGN (F1)**. The display will show:



#### CAUTION!

- For applications with temperature exceeding 250°F (121°C), CAL-V<sup>™</sup> test results may vary.
- Periodic inspection for damage and cleaning of the sensor elements is required.

## Operation

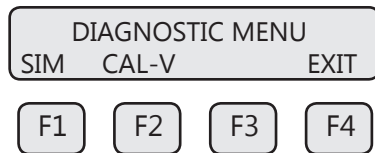

Press **CAL-V (F2)**.

The display will show:



Press **VER (F1)** to perform the CAL-V™ verification test.



**NOTE!** The FT4A will stop measuring flow when performing this test. Press **EXIT (F4)** to exit if you do not wish to continue.

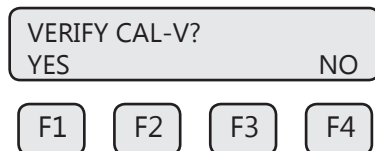

Press **YES (F1)** to to continue.

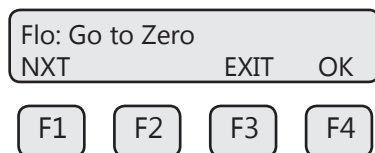

To select what the flow output will do during a CAL-V, choose from these options:

- Go To Zero: Flow output will be zero during the test (i.e. 4mA)
- Hold Value: Flow will hold last value during the test

Select the option and press **OK (F4)**.



**NOTE!** For accurate readings and best test results, perform a visual inspection of sensor window for damage/deformity and condition of sensor elements before starting the test.

## Operation

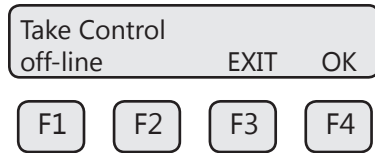

**WARNING!** If you are using a closed loop control, the system needs to be taken off-line during the test.

Press **OK (F4)** to start CAL-V™. CAL-V™ test screen:

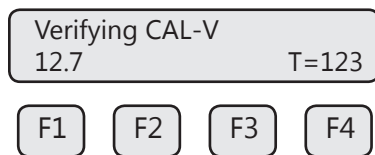

This test will take up to 4 minutes (less time if there is flow) and will show the CAL-V value changing as the power to the sensor is adjusted. "T=xxx" is a CAL-V timer indicating how much time is left to finish the test.

Upon test completion, the final CAL-V™ value will be displayed along with a Pass, Fail, or Warning message. The test result may be:

- Pass: less than  $\pm 0.80$
- Warning: between  $\pm 0.80$  to  $\pm 1.0$
- Fail: greater than  $\pm 1.0$

If a "Warning" or "Fail" result is displayed, Fox Thermal recommends that the probe be removed from the pipe, the sensor cleaned, and the test be performed again under a normal or high flow rate.

If a "Warning" or "Fail" result is displayed after performing the test a second time, please call Fox Thermal Service at (831) 384-4300 for assistance.

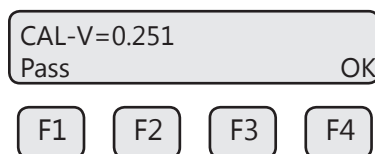

Press **OK (F4)** to exit the menu when the test is complete.

## Operation

### Gas-SelectX® Available Gases and Gas Mix Menus

This menu allows the user to select a gas or gas mix from a pre-calibrated list of gases/gas mixtures available on the Fox Thermal Model FT4A Flowmeter. When entering the FT4A gas menu the user will have three choices:

1. Pure Gas Menu (Pure Gas) - a list of 11 gases
2. Mixed Gas Menu (Mix) - a mixture of any gases available in the Pure Gas menu except Natural Gas (total must equal 100%)
3. Oil & Gas Menu (O&G Mix) Menu - any combination of the 12 gases in the Oil & Gas menu (total must equal 100%)

Pure Gas Menu	Mixed Gas Menu**	O & G Gas Menu**
Air	Air	Methane (C1)
Argon	Argon	Ethane (C2)
Butane	Butane	Propane (C3)
Carbon Dioxide (CO2)	Carbon Dioxide (CO2)	i-Butane (C4)
Methane	Ethane	n-Butane (C4)
Natural Gas *	Methane	Pentanes (C5)
Nitrogen	Nitrogen	Hexanes (C6)
Oxygen	Oxygen	Carbon Dioxide (CO2)
Helium	Helium	Nitrogen
Hydrogen	Hydrogen	Heptanes (C7)**
Propane	Propane	Octanes (C8)**
		Nonane+ (C9+)***

\* Natural gas is defined as the NAESB Natural Gas mix (94.9% Methane, 0.7% CO2, 1.6% N2, 0.3% Propane, and 2.5% Ethane).

\*\* The molar mass of the gases are programmable in 0.1% increments. Gases may be mixed in any proportion equaling 100%. Round compositions to the nearest 0.1 percent; rounding errors to be added/subtracted to Hexanes (C6).

\*\*\*Total of all gases C9 & greater (C9+).



**NOTE!** For the latest gas and gas mix menu, visit the Fox Thermal Website: [www.foxthermal.com](http://www.foxthermal.com)

## Operation

### Accessing the Gas-SelectX® Gas Selection Menu Feature

Enter the programming mode on the meter (refer to p. 40) and then follow these instructions to access the Gas-SelectX® feature:

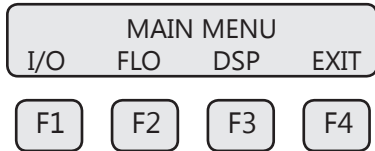

Press **FLO (F2)** from the Main Menu to enter Flow Menu 1.

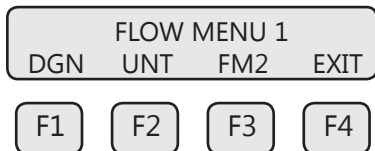

Press **FM2 (F3)** to get to Flow Menu 2.

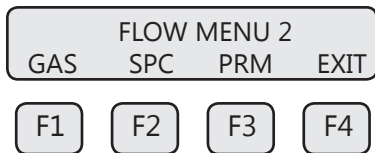

Press **GAS (F1)** to access the Gas-SelectX® feature. The display will show the gas setting (Pure Gas, Mix, or O&G Mix):



Press **NXT (F1)** repeatedly until the correct selection is shown and then press **OK (F4)** to accept the setting.

Selections are:

- Pure Gas
- Mix
- O&G Mix

In the Pure Gas menu, the user can choose from a list of 11 pure gases. The Mix menu is used for programming a specific mixture of gases. The O&G Mix menu is used for programming a specific mixture of common gases found in the Oil & Gas industry.



**NOTE!** Switching between Pure Gas, Mix, or O&G Mix settings will clear the previous gas settings.

See previous page for gases available in each menu.

## Operation

### Gas-SelectX® Single Gas Menu

To select a pure gas, choose Pure Gas and then press "**OK**" (**F4**) to accept the setting:

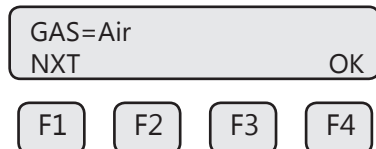

To choose any pure gas, press **NXT (F1)** to cycle through until the correct gas is displayed and press **OK (F4)** to select the gas. Choices are listed in full in "Gas-SelectX® Available Gases and Gas Mix Menus" on page 60.

### Choosing a Gas: Mixed Gas (MIX) Menu and Oil & Gas (O&G) Menu

To create a gas mix, choose either "Mix" or "O&G Mix" from the GAS menu.

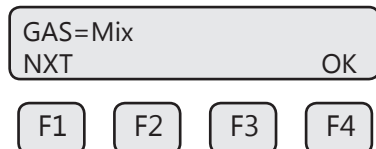

The screen will show the first gas available in the menu:

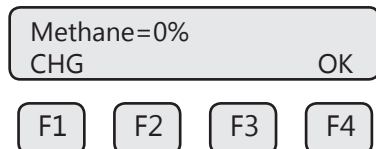

This screen shows the percentage of the gas mixture allocated to Methane. In this case, it shows 0%. To program the specific mixture of Methane, press **CHG (F1)**.

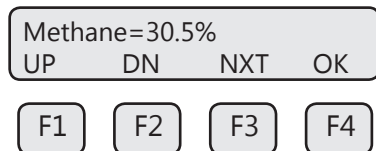

#### IMPORTANT NOTES!

- Gas mix must equal 100.0%
- Any gases not included in the gas mix should have percentages set to 0%.
- The entry for Nonane+ in the Oil and Gas menu includes all gases C9 and higher.

## Operation

To set the percentage of methane in the gas mix, press **UP (F1)** or **DN (F2)** to choose the first digit of the percentage. Press **NXT (F3)** to move to the next digit in the percentage and then use **UP (F1)** or **DN (F2)** again to choose the next digit of the percentage. Once the desired methane percentage is displayed, press **OK (F4)**. The display will move to the view of the concentration of each of the subsequent list of gases.

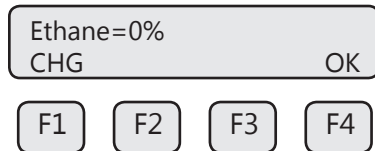

Once the desired gas percentages are set, press **OK (F4)**. One of the following messages will appear:

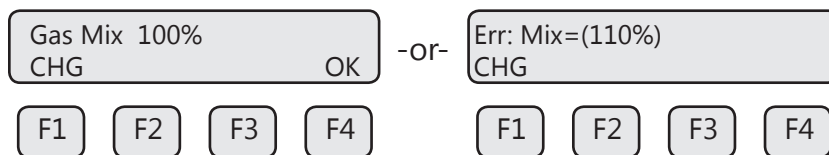

If the gas mix does not equal 100.0%, press **CHG (F1)** to return to the gas entry menu.

Once the Gas Mix message appears, you have successfully programmed the gas mix in Gas-SelectX® and can exit. Press **OK (F4)** to set the mixture.

After the gases are programmed, the FT4A will begin to monitor flow based on the pre-calibrated algorithm for the gas/gas mix selected in the Gas-SelectX® feature. The screen will show the flow in units and the total flow similar to the example below:

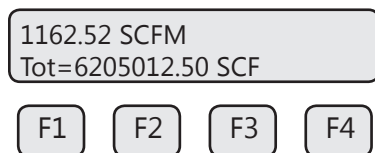

In normal operating mode, the gas selection can be seen on display 3 (see p. 39).

## Communications

### Modbus: Scope

This portion of the manual describes the Modbus implementation using RS485 serial communication physical layer for the Fox Thermal FT4A Mass flow meter based on the Modicon Modbus Protocol (PI-MBUS-300 Rev. J).

### Modbus Protocol

MODBUS Protocol is an application layer messaging protocol that provides client/server communications between devices. MODBUS is a request/reply protocol and offers services specified by function codes.

The size of the MODBUS Protocol Data Unit is limited by the size constraint inherited from the first MODBUS implementation on Serial Line network (max. RS485 Application Data Unit = 256 bytes).

Therefore, MODBUS PDU for serial line communication = 256 – Server address (1 byte) – CRC (2 bytes) = 253 bytes.

RS485 ADU = 253 + Server address (1 byte) + CRC (2 bytes) = 256 bytes.

For more information on MODBUS go to the web site <http://www.modbus.org/>.

Command Request:

<Meter Address> <Function code> <Register start address high> <Register start address low> <Register count high> <Register count low> <CRC high> <CRC low>

Command Response:

<Meter Address> <Function code> <Data byte count> <Data register high> <Data register low> ... <Data register high> <Data register low> <CRC high> <CRC low>



**NOTE!** The data shown in brackets < > represents one byte of data.

### Modbus Indicators

LED indicator LP3 cycles on and off to indicate that the FT4A is operating.

LED indicator LP2 blinks when Modbus signals are received and LP1 blinks when Modbus signals are transmitted.

### FT4A Commands Supported

The FT4A supports the following commands:

1. Command 03: Read holding registers
2. Command 04: Read input register.
3. Command 06: Preset single register



## Communications

### Read Holding Registers (command 03)

This command reads the basic variable from the FT4A and has the following format:

Request:

<Meter Address> <Command code=03> <Register start address high> <Register start address low> <Register count high> <Register count low> <CRC high> <CRC low>

Response:

<Meter Address> <Command code=03> <Byte count> <Data high><Data low> ... <Data high><Data low> <CRC high> <CRC low>

Example:

Request data register at starting address 0x0000 and specifying only 1 register

<0x01> <0x03> <0x00> <0x00> <0x00> <0x01> <0x84> <0x0A>

Response:

<0x01> <0x03> <0x02> <xx> <xx> <CRC high> <CRC low>

Where xx xx is the data register value.

Table 5.1: FT4A Modbus Holding Registers

Address	Address	Data Type	Scaling	Comment
0x00	40001	Flow in Eng units (low)	No	Mass flow in selected units
0x01	40002	Flow in Eng units (high)	No	
0x02	40003	Total (low)	No	Total in selected units
0x03	40004	Total (High)	No	
0x04	40005	Temperature (low)	*10	Temperature in selected units * 10
0x05	40006	Temperature (high)	*10	
0x06	40007	Elapsed time (low)	*10	Elapsed time in hours * 10
0x07	40008	Elapsed time (high)	*10	
0x08	40009	Spare/not used		
0x09	40010	Spare/not used		
0x0A	40011	Flow in Eng units * 10	10	Mass flow in selected units * 10
0x0B	40012	Flow in Eng units *100	100	Mass flow in selected units * 100
0x0C	40013	Total *100	100	Total in selected units * 100
0x0D	40014	Spare/ Not used		
0x0E	40015	Spare/ Not used		

# Communications

Address	Address	Data Type	Scaling	Comment
0x0F	40016	Status	No	Status
0x10	40017	Status 2	No	
0x11	40018	Control Register (Write Only): Reset total =2 Perform_CAL_V = 173 Abort CAL-V = 174	No	Control Register
0x12	40019	Spare/ Not used		
0x13	40020	Flow in Eng units (float, upper 16 bits)	No	Mass flow in selected units
0x14	40021	Flow in Eng units (float, lower 16 bits)	No	Mass flow in selected units
0x15	40022	Total in Eng units (float, upper 16 bits)	No	Total in selected units
0x16	40023	Total in Eng units (float, lower 16 bits)	No	Total in selected units
0x17	40024	Spare/ Not used		
0x18	40025	Spare/ Not used		
0x19	40026	Temperature in selected units (float, upper 16 bits)	No	Temperature in selected units
0x1A	40027	Temperature in selected units (float, lower 16 bits)	No	Temperature in selected units
0x1B	40028	Elapsed time in hours (float, upper 16 bits)	No	Elapsed time in hours
0x1C	40029	Elapsed time in hours (float, lower 16 bits)	No	Elapsed time in hours
0x1D	40030	CAL-V (float, upper 16 bits)	No	
0x1E	40031	CAL-V (float, lower 16 bits)	No	
0x37	40056	Gas Select (int, low register)	No	Gas select: single gas, mix gas or O&G mix
0x38	40057	Gas select (int, msb register)	No	Gas select: single gas, mix gas or O&G mix
0x39	40058	CH4 percent (float LSB)	No	CH4 percent
0x3A	40059	CH4 percent (float MSB)	No	CH4 percent
0x3B	40060	CO2 percent (float LSB)	No	CO2 percent
0x3C	40061	CO2 percent(float MSB)	No	CO2 percent
0x3D	40062	N2 percent (float LSB)	No	N2 percent
0x3E	40063	N2 percent (float MSB)	No	N2 percent
0x3F	40064	Air percent (float LSB)	No	Air percent

## Communications

Address	Address	Data Type	Scaling	Comment
0x40	40065	Air percent (float MSB)	No	Air percent
0x41	40066	Argon percent (float LSB)	No	Argon percent
0x42	40067	Argon percent (float MSB)	No	Argon percent
0x43	40068	Propane percent (float LSB)	No	Propane percent
0x44	40069	Propane percent (float MSB)	No	Propane percent
0x45	40070	Helium percent (float LSB)	No	Helium percent
0x46	40071	Helium percent (float MSB)	No	Helium percent
0x47	40072	Oxygen percent (float LSB)	No	Oxygen percent
0x48	40073	Oxygen percent (float MSB)	No	Oxygen percent
0x49	40074	Butane percent (float LSB)	No	Butane percent
0x4A	40075	Butane percent (float MSB)	No	Butane percent
0x4B	40076	Hydrogen percent (float LSB)	No	Hydrogen percent
0x4C	40077	Hydrogen percent (float MSB)	No	Hydrogen percent
0x4D	40078	ISO butane percent (float LSB)	No	Iso Butane percent
0x4E	40079	ISO butane percent (float MSB)	No	Iso Butane percent
0x4F	40080	Ethane percent (float LSB)	No	Ethane percent
0x50	40081	Ethane percent (float MSB)	No	Ethane percent
0x51	40082	Pentane percent (float LSB)	No	Pentane percent
0x52	40083	Pentane percent (float MSB)	No	Pentane percent
0x53	40084	Hexane percent (float LSB)	No	Hexane percent
0x54	40085	Hexane percent (float MSB)	No	Hexane percent
0x55	40086	Heptane percent (float LSB)	No	Heptane percent
0x56	40087	Heptane percent (float MSB)	No	Heptane percent
0x57	40088	Octane percent (float LSB)	No	Octane percent
0x58	40089	Octane percent (float MSB)	No	Octane percent
0x59	40090	Nonane percent (float LSB)	No	Nonane percent
0x60	40091	Nonane percent (float MSB)	No	Nonane percent



**NOTE!** Registers A, B & C are provided to get more resolution for low flow and total. When value exceeds the 16 bit registers, they will be frozen with all 16 bits set.

## Communications

### Read Input Register (FT4A Status, Command 04)

This command is used to report the FT4A status information.

Request:

<Meter Address> <Command code=04> <Register address =0> <Register address =0>  
<Register count =0> <Register count =1> <CRC high> <CRC low>

Response:

<Meter Address> <Command code=04> <Byte count =2> <Status High> <Status Low>  
<CRC high> <CRC low>

Table 5.2: Status Bits Definitions for Command 04, Modbus Address 30001

Bit	Definition	Comment
0	Power up indication	Cleared when out of the power up sequence
1	Flow rate reached high limit threshold	Set limit to zero to disable
2	Flow rate reached low limit threshold	Set limit to zero to disable
3	Temperature reached high limit threshold	Set limit to zero to disable
4	Temperature reached low limit threshold	Set limit to zero to disable
5	Sensor reading is out of range	Check sensor wiring
6	Gas mix error	Gas mix must total 100%
7	Incorrect Settings	Check settings
8	In simulation mode	Set simulation value to 0 to disable
9	Pulse/alarm output is out of range	Check pulse/alarm output settings
10	Analog 4-20 mA for flow/temp is out of range	Check analog output settings
11	Not used	Not used
12	Not used	Not used
13	Not used	Not used
14	CRC error	Check parameters and reset CRC
15	Error in Total	Reset total to clear alarm

Table 5.3: Status 2 Bits Definitions for Command 04, Modbus Address 30002

Bit	Definition	Comment
0	Pulse hardware detected	
1	Busy	Busy
2	Not used	Not used
3	Not used	Not used
4	CAL-V in process	
5	CAL-V fail	

## Communications

Bit	Definition	Comment
6	CAL-V aborted	
7	CAL-V warning	

### Preset Single Register (Command 06)

This command is used to perform miscellaneous functions such as clearing the totalizer and elapsed time. The register address is Modbus=40018 and the data to write is described below.

Request:

<Meter Address> <Command code=06> <Register address high=0x00> <Register address low=0x11> <Register data high=0x00> <Register data low =0x02> <CRC high> <CRC low>

Response:

<Meter Address> <Command code=06> <Register address =0x00> <Register address =0x11> <Register data=0x00> <Register data =0x02> <CRC high> <CRC low>

Reset Total:

Address = 40018, data = 0x02

This command is used to clear the Totalizer and elapsed time registers

### Enter the Programming Mode - RS485 Modbus RTU

Press the **F1** or the **F2** key repeatedly, in the normal running mode, until the following screen is shown. This enters the programming mode:

SET PARAMETERS?			
NO	YES		
F1	F2	F3	F4

Press **YES (F4)** and then the following screen will prompt the user to enter the password if enabled:

PASWD:_			
UP	DN	NXT	OK
F1	F2	F3	F4

Enter the correct password. Default password for Level 1 is 1234.

Press the **UP (F1)** or **DN (F2)** key to select a new digit or character, the cursor points to the selected digit. Press **NXT (F3)** to select the next digit and **OK (F4)** to accept the entry.

## Communications

If the wrong password is entered, the message "Wrong Password" will be displayed for a few seconds and then return to the programming entry screen. If the password is accepted, the following screen will be shown:

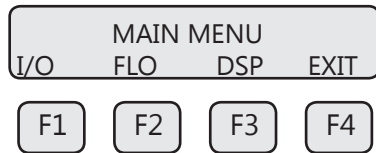

This is the Main Menu for the programming mode. To exit the programming mode, press **EXIT (F4)** repeatedly until "Normal Mode" is seen briefly.

### Modbus Communication Protocol and Parameters

To program the communication parameters, start at the Main Menu:

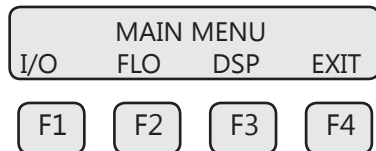

Then press **I/O (F1)** to set Inputs/Outputs:

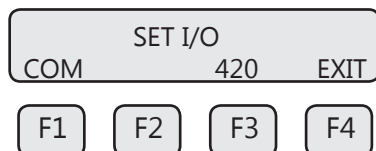

Then press **COM (F1)** to select communication parameters.

Set Bus protocol for Modbus:

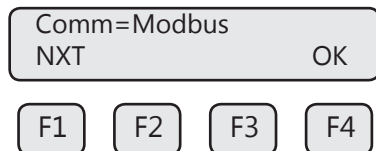

Press **NXT (F1)** repeatedly until Modbus is selected as shown and then press **OK (F4)** to accept the setting.

The following communication parameters are only available for MODBUS:

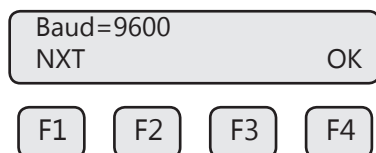

## Communications

Press **NXT (F1)** repeatedly until the correct selection is shown and then press **OK (F4)** to accept the setting.

Selections are:

- 115200
- 76800
- 57600
- 38400
- 19200
- 9600
- 4800
- 2400
- 1200

Parity=EVEN NXT	OK		
F1	F2	F3	F4

Press **NXT (F1)** repeatedly until the correct selection is shown and then press **OK (F4)** to accept the setting.

Selections are:

- NONE
- ODD
- EVEN

Address=02 CHG	OK		
F1	F2	F3	F4

Press **CHG (F1)** to change the address and then press **OK (F4)** to accept the setting.

Selections are between 01 and 247.



**NOTE!** Power cycle is required for the new settings to take effect.

## Communications

### HART Communications: Scope

The Fox Thermal Model FT4A transmitter complies with HART Protocol Revision 7.1. This section specifies all the device-specific features and documents HART Protocol implementation details (e.g., the Engineering Unit Codes supported). The functionality of this Field Device is described sufficiently to allow its proper application in a process and its complete support in HART-capable Host Applications.

### Purpose

This section provides a complete description of this Field Device from a HART Communication perspective.

The specification in this section is designed to be a technical reference for HART capable Host Application Developers, System Integrators and knowledgeable End Users. It also provides functional specifications (e.g., commands and performance requirements) used during development, maintenance and testing. The information given in this section assumes the reader is familiar with HART Protocol requirements and terminology.

### References

HART Smart Communications Protocol Specification. HCF\_SPEC-12. Available from the HCF.

### Device Identification

Manufacturer Name:	Fox Thermal Instruments, Inc.	Model Name(s):	FT4A
Manufacturer ID Code:	24635 (603b hex)	Device Type Code:	57583 (EOEF Hex)
HART Protocol Revision	7.1	Device Revision:	1
Number of Device Variables	None		
Physical Layers Supported	FSK		
Physical Device Category	Transmitter, DC-isolated Bus Device		

### Product Overview

HART communication is transmitted over the FT4A 4-20mA flow output signal and can be monitored and configured using a HART master device or a hand-held communicator.



## Communications

### Process Flow Rate 4-20mA Analog Output

The 4-20mA output of the FT4A HART represents the process flow rate measurement, linearized and scaled according to the configured range of the instrument. This output corresponds to the Primary Variable. HART Communication is supported on this loop.

The 4-20mA output of the FT4A should be configured for flow rate when using HART. If the 4-20mA output is set to report temperature, HART communication will report the 4-20mA value for temperature rather than flow.

### HART Indicators

LED indicator LP3 cycles on and off to indicate that the FT4A is operating.

LED indicator LP2 blinks when HART signals are received and LP1 blinks when HART signals are transmitted (if nothing is connected to the 4-20mA output, LP2 will be on continuously).

### FT4A HART Communication Setup

HART communication must be selected in the FT4A Serial Communication menu for HART communication to operate. When this communication parameter is changed, power to the FT4A must be cycled for it to take effect.

### Enter the Programming Mode - HART

Press the F1 or the F2 key repeatedly, in the normal running mode, until the following screen is shown. This enters the programming mode:

SET PARAMETERS?			
NO			YES
F1	F2	F3	F4

Press **YES (F4)** and then the following screen will prompt the user to enter the password if enabled:

PASWD:_			
UP	DN	NXT	OK
F1	F2	F3	F4

Enter the correct password. Default password for Level 1 is 1234.

# Communications

## HART Communication Protocol and Parameters

To program the communication parameters, press **I/O (F1)** key from the main menu.

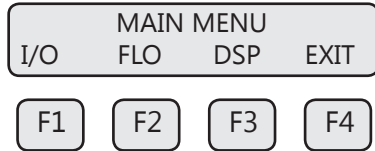

This is the main menu for the programming mode. To exit the programming mode, press **EXIT (F4)** repeatedly until "Normal Mode" is seen briefly. Choose **I/O (F1)** to access the communication output.

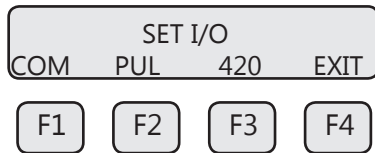

Then press **COM (F1)** to select communication parameters

Set Bus protocol for HART:

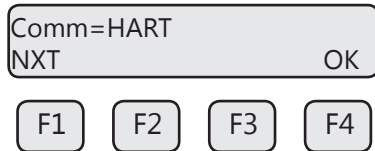

Press **NXT (F1)** until HART is selected as shown and then press **OK (F4)** to accept the setting.



**NOTE!** Power cycle is required for the new settings to take effect.

### Device Variables

This device does not expose any Device Variables.

### Dynamic Variables

Four Dynamic Variables are implemented.

	Meaning	Units
PV	Flow Rate	In Selected Units
SV	Total	In Selected Units
TV	Temperature	In Selected Units
QV	Elapsed Time	In Hours

# Communications

## Status Information

### Device Status

Bit 4 ("More Status Available") is set when any failure is detected. Command #48 provides additional detail.

### Extended Device Status

This bit is set if a sensor error is detected. "Device Variable Alert" is set if the PV is out of limit.

### Additional Device Status (Command #48)

Command #48 returns 2 Device-Specific Status bytes of data, with the following status information:

These bits are set when an alarm or error condition is present. The bit automatically clears when the condition returns to its normal state.

Byte	Bit	Meaning	Class
0	0	Power up indication	Status
	1	High Flow Limit Alarm	Alarm
	2	Low Flow Limit Alarm	Alarm
	3	High Temperature Limit Alarm	Alarm
	4	Low Temperature Limit Alarm	Alarm
	5	Sensor out of range	Error
	6	Mix error	Alarm
	7	Check Parameter Settings	Error
1	0	In Simulation Mode	Alarm
	1	Frequency output out of range	Alarm
	2	CH 1 4-20mA out of range	Alarm
	3	Not used	
	4	Not used	
	5	Not used	
	6	CRC database error	Error
	7	Error with Total	Error

## Communications

---

### Common-Practice Commands, Supported Commands

The following common-practice commands are implemented:

34	Write Damping Value
35	Write Range Values
36	Set PV Upper Range Values
37	Set PV Lower Range Values
38	Reset "Configuration Changed" Flag
40	Enter/Exit Fixed Current Mode
44	Write PV Units
45	Trim Loop Minimum
46	Trim Loop Maximum
48	Read Additional Device Status (Command #48 returns 2 bytes of data)
59	Write Number of Response Preambles

### Common-Practice Commands, Unsupported Commands

#### Burst Mode

This device does not support Burst Mode.

#### Catch Device Variable

This device does not support Catch Device Variable.

#### Device-Specific Commands

No Device-Specific commands are implemented.

#### Modes

Fixed current mode is implemented, using Command 40. This mode is cleared by power loss or reset.

#### Damping

Damping is standard, affecting only the PV and the loop current signal.

## Communications

### Capability Checklist

Manufacturer, model	Fox Thermal Instruments, FT4A
Device type	Transmitter
HART revision	7.1
Device Description available	No
Number and type of sensors	1
Number and type of actuators	0
Number and type of host side signals	1 : 4-20mA analog
Number of Device Variables	0
Number of Dynamic Variables	4
Mappable Dynamic Variables	No
Number of common-practice commands	17
Number of device-specific commands	0
Bits of additional device status	8
Alternative operating modes	No
Burst mode	No
Write-protection	Yes

## Maintenance

---

### Maintenance: Precautions



**WARNING!** BEFORE ATTEMPTING ANY MAINTENANCE, TAKE THE NECESSARY SAFETY PRECAUTIONS BEFORE REMOVING THE PROBE FROM THE DUCT (EXAMPLE: PURGE LINES OF TOXIC AND/OR EXPLOSIVE GAS, DEPRESSURIZE, ETC...).



**WARNING!** EXPLOSION HAZARD. DO NOT REMOVE OR REPLACE COMPONENTS OR FUSES UNLESS POWER HAS BEEN DISCONNECTED WHEN A FLAMMABLE OR COMBUSTIBLE ATMOSPHERE IS PRESENT.



**WARNING!** EXPLOSION HAZARD. DO NOT DISCONNECT EQUIPMENT WHEN A FLAMMABLE OR COMBUSTIBLE ATMOSPHERE IS PRESENT.

### Access to Electronics

Accessing electronics is not normally required for maintenance purposes. If a loose connection is suspected, unscrew the cap of the meter, unscrew the two phillips captive screws through the display and open the display assembly to access the wiring terminations.



**CAUTION!** BE SURE POWER TO METER IS SWITCHED OFF BEFORE ATTEMPTING TO ACCESS ELECTRONICS. If there is a problem and a loose connection is not found, please contact Fox Thermal Customer Service for technical assistance at (831) 384-4300.

### Removing Flow Meter from Retractor



**CAUTION!** Ensure the process pressure is less than 150 psig before retracting the meter. Attempting to retract the meter when the process pressure is above 150 psig is dangerous and may result in injury and/or damage to the equipment.



**CAUTION!** If gas pressure ejects the flow meter from the pipe onto the restraint cable assembly, do not reinstall the flow meter back into the pipe if the retractor or cable assembly have been damaged.

## Maintenance

---

### Broken or Damaged Probe

If the sensor is broken or damaged, the probe and electronics must be returned to the factory for repair. A new sensor will be installed and calibrated. Refer to "Returning Your Meter" on p. 98.

### Flow Calibration and Calibration Validation

To ensure continued high accuracy of your Model FT4A Flow Meter, Fox Thermal provides a full NIST traceable calibration. It is recommended that the meter's accuracy be checked annually by performing the CAL-V® Calibration Validation test.

### Fuse Replacement



**WARNING!** Turn input power OFF before removing or installing a fuse. Use only recommended fuse replacements.

Verify the fuse is defective by measuring it with an Ohm Meter (Two replacement fuses are provided with each unit). Replacement fuse is Littelfuse part number 0454.750MR

### To replace the fuse:

The fuse F1 is located near the power terminal block and can be removed by using tweezers or needle-nose pliers.

### Sensor Cleaning

The sensor is insensitive to small amounts of residue, but continued use in dirty environments will necessitate periodic cleaning. To inspect the sensor, remove power from electronics and remove the unit from the pipe or duct, exposing the sensor elements. If they are visibly dirty, clean them with water or alcohol (ethanol) using an appropriate brush until they appear clean again. Even though the sensor elements are rugged, avoid touching them with any solid object and use a light touch while cleaning them.



**NOTE!** Sensor elements require inspection per BLM and API standards.

## Maintenance

### Instructions for Removing and Inserting the Meter from a Pressurized Pipe using the Retractor



**WARNING!** Possible injury or damage to equipment may occur if the retractor is not used correctly. Please read the following instructions carefully prior to using the retractor.



**CAUTION!** Never remove the restraint cable without first closing the Ball Valve and bleeding off pressure.



**WARNING!** When working with the retractor, do not stand or position any part of your body in the path of the flow meter. An injury may occur if the probe is forced outward by system pressure.

### How to Remove the Meter from the Retractor (System Pressurized)

#### Step 1 - Remove the Probe from the Flow Stream

1. Disconnect power from the meter.



**NOTE!** At 150psig of max system pressure, the probe will have approximately 66 lbs. of force pushing it out.

2. System pressure may force the probe out of the retractor when the Swage Nut is loosened. Hold the flow meter to counteract the force of the system pressure, and carefully loosen and unscrew the Swage nut.
3. While supporting the meter, slowly slide the probe out of the retractor until the restraint cable is tight.
4. Close the ball valve all the way.



**CAUTION!** At this point there is still pressure inside of the retractor.

Figure 6.1

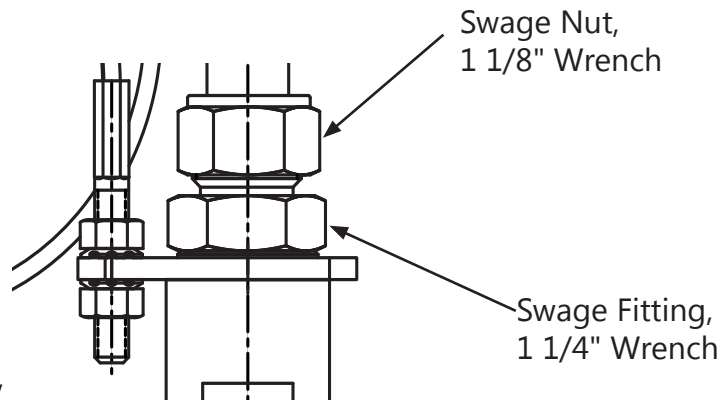



## Maintenance

### Step 2 - Remove the Probe from the Retractor Body

5. After removing the probe from the flow stream (#1-4 on previous page), slowly loosen the Swage Fitting (see figure 6.2), until the pressure in the retractor is relieved.
6. Retighten the Swage Fitting.
7. Remove the Collar Clamp by using a 3/16" Hex Key.
8. Carefully slide the probe out of the retractor while supporting the meter.

Figure 6.2

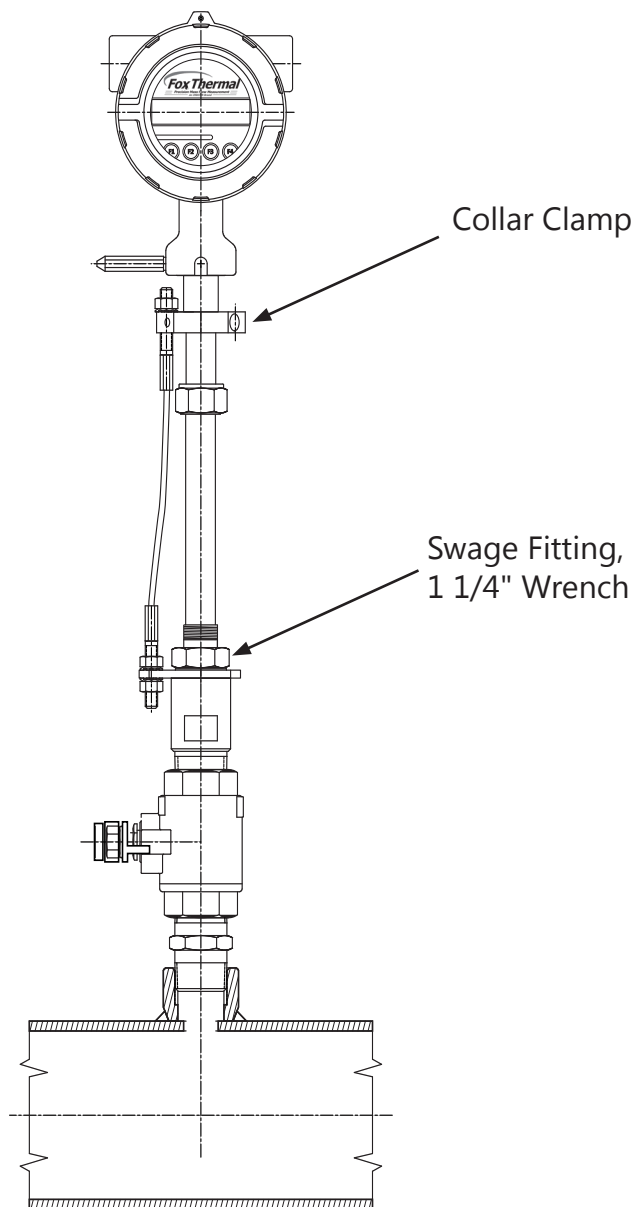

## Maintenance

### How to Insert the Probe into the Flow Stream (Valve closed, System Pressurized)

1. Carefully, slide the probe into the retractor.
2. Install the collar clamp just below the collar spacer, and tighten it in place on the probe. Slide the probe back out of the retractor until the cable is straight and taut.

Figure 6.3

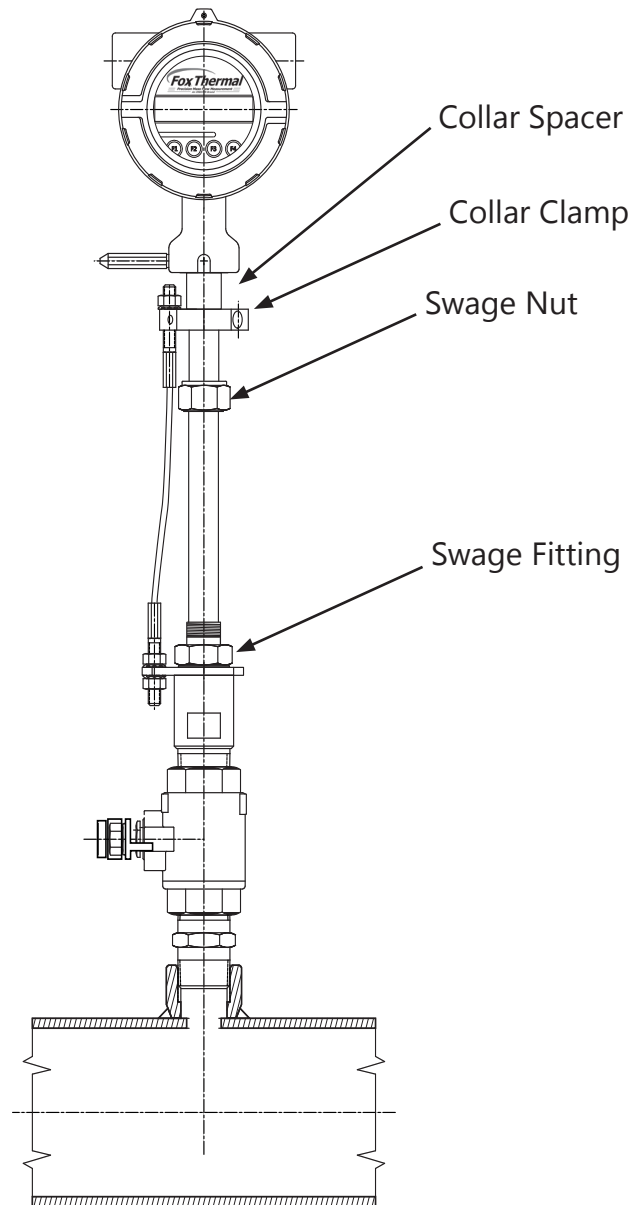

**NOTE!** At a maximum system pressure of 150psig, the force required to push the probe in place to tighten the Swage Nut will be approximately 66 lbs.

## Maintenance

3. Slowly open the ball valve to the full open position. Push the meter and probe into the pipe, then hand tighten the Swage Nut onto the Swage Fitting.
4. Verify that the probe is aligned with the centerline of the pipe, and pointed in the direction of flow.

Figure 6.4

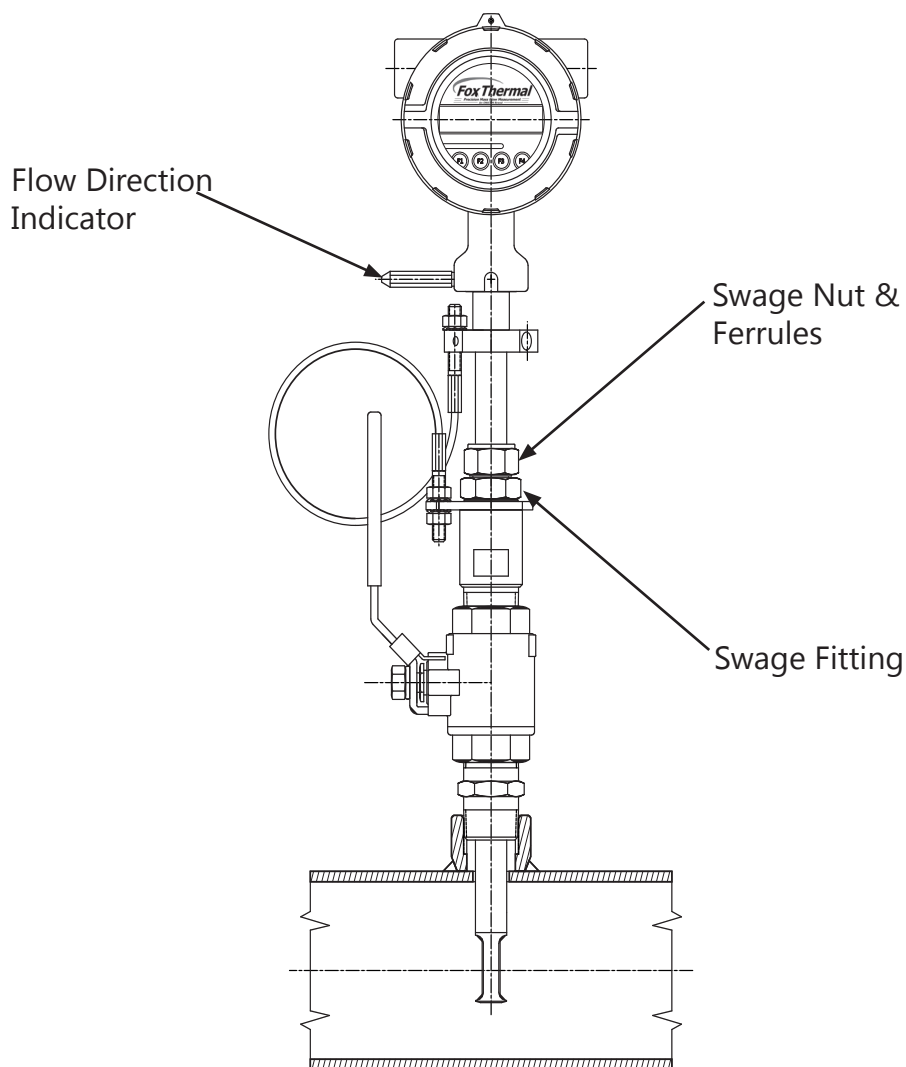

5. Secure the probe in place by tightening the Swage Nut with a 1 1/8" wrench and a 1 1/4" wrench on the Swage Fitting. See p. 24 of the manual for detailed instructions to tighten the swage nut.
6. Power may now be applied to the meter.

# Troubleshooting

## Troubleshooting



**CAUTION!** The electronics and sensor supplied by Fox Thermal are calibrated as a single precision mass flow meter. Interchanging sensors will decrease the accuracy of the flow meter. If you experience any problem with your Model FT4A Flow meter, call Fox Thermal Customer Service Department, Technical Assistance at (831) 384-4300.

### LED Indicators

The LED indicators near the terminal blocks of the FT4A display the status of the FT4A. The Heartbeat LED blinks fast when the FT4A is powered up, and blinks about once a second when the FT4A operates normally.

The Transmit and Receive LEDs blink when messages are sent and received through serial communication. The Receive LED may be illuminated if the FT4A has HART communication and the 4-20mA output is not connected.

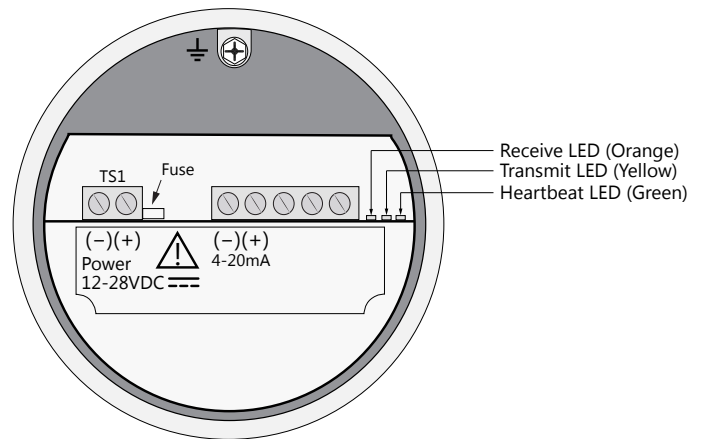

Problem	Possible Cause(s)	Action(s)
Display not operating properly	<ol style="list-style-type: none"> <li>Loose or damaged ribbon cable</li> <li>Temperature below -20°C</li> </ol>	<ol style="list-style-type: none"> <li>Visual inspection.</li> <li>Cycle the power to reset the meter.</li> <li>Display should operate when ambient temperature is above -20°C</li> </ol>
Flow measurement seems low	<ol style="list-style-type: none"> <li>Probe not oriented properly</li> <li>Sensor dirty</li> </ol>	<ol style="list-style-type: none"> <li>Orient probe per installation sections: Insertion (p. 22),</li> <li>Perform CAL-V test</li> <li>Clean sensor (p. 79)</li> </ol>
Unit will not power-up	<ol style="list-style-type: none"> <li>No power input</li> <li>Power connections reversed</li> <li>Bad Power supply</li> <li>Bad fuse</li> </ol>	<ol style="list-style-type: none"> <li>Check for correct power supply voltage at TS1 on main board.</li> <li>Check fuse (F1) located next to TS1 on main board.</li> </ol> <p>If fuse is OK and unit still won't power up, call Fox Thermal for additional assistance</p>



# Troubleshooting

Problem	Possible Cause	Action
Meter resets	<ol style="list-style-type: none"> <li>1. Electromagnetic interference (EMI)</li> <li>2. Low power supply voltage or intermittent power</li> </ol>	<ol style="list-style-type: none"> <li>1. Check meter power cycles value</li> <li>2. Press and release F1 and F2 at the same time; the display will enter Engineering screens.</li> <li>3. Press F1 to get to screen #23; record power cycle value.</li> <li>4. Press F4 to return to normal operation; monitor meter until problem returns.</li> <li>5. Return to screen #23 to see if power cycles have increased; microprocessor is resetting due to EMI electrical noise entering the meter.</li> <li>6. Check Power input and output cables grounding and routing.</li> </ol>
Flow measurement is erratic or fluctuating	<ol style="list-style-type: none"> <li>1. Very turbulent flow</li> <li>2. Sensor dirty</li> <li>3. Sensor broken</li> <li>4. Probe not mounted securely</li> <li>5. Malfunction in flow meter</li> <li>6. Meter installed incorrectly</li> <li>7. Low power supply voltage or intermittent power</li> </ol>	<ol style="list-style-type: none"> <li>1. Increase dampening (see filter settings in "Flow Parameters" on p. 51)</li> <li>2. Clean sensor (Refer to Maintenance section, p. 79)</li> <li>3. Return flow meter to Fox Thermal for repair (Refer to p. 98 for shipping instructions)</li> <li>4. Remount probe (see Installation section, p. 24); must be mounted securely without vibration. If vibration persists, choose a new mounting location without vibration.</li> <li>5. Return flow meter to Fox Thermal for repair (Refer to p. 98 for shipping instructions)</li> <li>6. Re-install meter according to instructions (Refer to installation section, p. 19)</li> <li>7. Check power input and output cables grounding and routing.</li> </ol>



## Troubleshooting

### Troubleshooting CAL-V®

If the FT4A Meter fails a CAL-V® Calibration Validation test, there are a few reasons that could be the cause:

1. The sensor may be dirty or damaged
  - Visually inspect the meter and sensor for damage. If damage is found, meter may need to be serviced. Contact Fox Thermal Technical Assistance at 831-384-4300 for more information
  - Try cleaning the sensor and try the test again
  - If the meter fails again, contact Fox Thermal Technical Assistance at 831-384-4300 for more information



## Troubleshooting

### Installation Problems

The following is a summary listing of problems that may be encountered with the installation of the FT4A Thermal Mass Flow Meter.

- 1. Improper wiring connections for power and/or 4-20mA output signal.*  
A separate power source is recommended for the FT4A main board and the 4-20mA output signals. Two wires supply 24VDC power to the main board. Two wires are used for the 4-20mA output signals. Refer to Figure 3.3 and Figure 3.4 (p. 32, p. 33). Also refer to "Wiring Precautions" in Wiring section (p. 29) for further guidance.
- 2. Inadequate power source.*  
The FT4A requires 12 to 28VDC at up to 6 Watts to operate. A 20 Watt power supply is recommended for powering the FT4A to ensure it operates properly under all conditions. If the voltage supplied at the input terminals of the FT4A is not within the range of 10VDC to 30VDC, a variety of problems can occur including a dim display, inaccurate flow readings or faulty 4-20mA, pulse and communication interface.
- 3. Flow measurement seems inaccurate.*

  - Check to ensure that the flow meter is installed so that the Flow Direction Indicator below the electronics housing is properly pointing in the direction of flow. Refer to Figure 2.5 (p. 22). If not, change orientation of the sensor.
  - Check that the insertion depth of the sensor/probe is correct. The end of the probe should be adjusted as per Figure 2.2 (p. 21).
  - For insertion meters, ensure that there are a minimum of fifteen diameters of straight pipe upstream of the sensor and ten diameters downstream. For inline meters, ensure that there are a minimum of ten diameters of straight pipe upstream of the sensor and five diameters downstream. If complex flow disturbances are upstream of the sensor, extension of the straight pipe may be required to ensure accurate flow measurement. Contact Fox Thermal for assistance.
  - Ensure that pipe inside diameter in the meter matches data on the Fox Thermal Calibration Certificate. The pipe inside diameter is programmed into the flow meter through the front panel (see Flow Parameters, p. 51).
- 4. Erratic flow reading (especially a flow reading spiking high).*  
This may be a symptom of moisture in the flow stream. Fox Thermal flow meters are designed to work in relatively dry gas applications only. Contact Fox Thermal to discuss resolutions to this problem.
- 5. Flow meter is not responding to flow.*

  - Check to ensure adequate power is supplied to the flow meter. If things appear to be correct, perform this functional test before calling Fox Thermal. Carefully remove the probe and sensor from the pipe. For those flow meters with a display - and if the display is reading zero - take a damp rag or sponge and place it in contact with the sensor. A reading should occur. Contact Fox Thermal Customer Service with this information.
- 6. Display and/or 4-20mA signal reading above zero flow when no flow is occurring in the pipe.*  
If the reading is less than 5% of full scale, it is likely this is a normal condition caused by convection flow in the pipe. It does not mean that the zero of the instrument is improperly set. The Fox Thermal sensor is extremely sensitive to gas flow and can even read the small flow caused by convection. If this is an unacceptable condition, please contact Fox Thermal Customer Service for alternatives.



# Troubleshooting

## Alarm Codes

Information to diagnose and clear alarm codes is on p. 7 under the Menu Tree section. Enter password (9111) and follow the block diagram to get to the section affected by the error code.

Alarm Code	Reason	Action
13	Flow rate above high limits	Refer to the FLOW MENU 2 section on p. 51 of this Manual to verify limit is within range. Check ALM = HiFloAlm under PRM.
14	Flow rate below low limits	Refer to the FLOW MENU 2 section on p. 51 of this Manual to verify limit is within range. Check ALM = LoFloAlm under PRM.
15	Temperature above high limits	Refer to the FLOW MENU 2 section on p. 51 of this Manual to verify limit is within range. Check ALM=HiTempAlm under PRM.
16	Temperature below low limits	Refer to the FLOW MENU 2 section on p. 51 of this Manual to verify limit is within range. Check ALM = LoTempAlm
22	Sensor out of range	Refer to the ENGINEERING DISPLAY MENU on p. 11 of this Manual to check CSV voltage. The CSV voltage in Display 10 must be within the range of 0.002 to 0.3125 volts.
23	Gas mix error	Gas mix must equal 100%.
25	Simulation mode	Meter is in Simulation Mode. Refer to the FLOW MENU 1 section on p. 55 of this Manual. Use the SIM Section under Diagnostics to return to normal operation.
26	Pulse/alarm output over range	Refer to the DIGITAL OUTPUT MENU on p. 5 of this Manual. Verify the Pulse/alarm Output settings are within limits.
32	4-20mA is out of range	Refer to the MAIN MENU on p. 4 of this Manual. Use the Set I/O section to verify range limits.
34	Busy	Meter is recalculating new parameters.
36	Database CRC Error	Refer to the Reset CRC section on p. 54 of this manual. Verify the programmed values are verified and corrected before clearing the error. Contact Fox Thermal Service Department for possible causes.





# Appendices

## Performance Specs

### Flow Accuracy:

- Air:  $\pm 1\%$  of reading  $\pm 0.2\%$  of full scale
- Other gases:  $\pm 1.5\%$  of reading  $\pm 0.5\%$  of full scale
- Accuracy specification applies to customer's selected flow range
- Maximum range: 15 to 60,000 SFPM (0.07 to 280 NMPS)
- Minimum range: 15 to 1,000 SFPM (0.07 to 4.7 NMPS)
- Straight, unobstructed pipe requirement:
  - Insertion meters: 15 diameters upstream; 10 downstream
  - Inline meters: 8 diameters upstream; 4 downstream

Gross Heating Value Uncertainty:  $\pm 0.01\%$  of mass basis;  $\pm 1.0\%$  on volume basis

Flow Repeatability:  $\pm 0.2\%$  of full scale

Flow Response Time: 0.8 seconds (one time constant)

Temperature Accuracy:  $\pm 1^\circ$  F ( $\pm 0.6^\circ$  C)

### Calibration:

- Factory Calibration to NIST traceable standards
- CAL-V<sup>®</sup>: In situ, operator-initiated calibration validation

## Operating Specs

### Gas-SelectX<sup>®</sup> Gas Selections:

Pure gas menu, Gas Mix Menu, and Oil & Gas Mix Menu. See the Fox Thermal website for more information on availability of current gases.

### Units of Measurement (field selectable):

SCFM, SCFH, NM<sup>3</sup>/H, NM<sup>3</sup>/M, KG/H, KG/M, KG/S, LB/H, LB/M, LB/S, NLPH, NLPM, MMSCFD, LB/D, SLPM, NLPS, MSCFD, SM<sup>3</sup>/H, MT/H, NM<sup>3</sup>/D, MMSCFM, SCFD, MCFD, SM<sup>3</sup>/M, SM<sup>3</sup>/D

Flow Velocity Range for Insertion flow meters: 15 to 60,000 SFPM (0.07 to 280 NMPS)

Turndown: up to 1000:1; 100:1 typical

Flow Ranges - Insertion Meters		
Pipe Diameter	SCFM	NM <sup>3</sup> /hr
1.5" (40mm)	0-210	0-330
2" (50mm)	0-350	0-550
3" (80mm)	0-770	0-1,210
4" (100mm)	0-1,330	0-2,100
6" (150mm)	0-3,000	0-4,730
8" (200mm)	0-5,210	0-8,220
10" (250mm)	0-32,800	0-51,740
12" (300mm)	0-11,700	0-18,450

**NOTE!** To determine if the FT4A will operate accurately in other pipe sizes, divide the maximum flow rate by the pipe area. The application is acceptable if the resulting velocity is within the velocity range above. Check Fox Thermal website for velocity calculator.

Flow Ranges - Inline Meters		
Size	SCFM	NM <sup>3</sup> /hr
1.5" (40mm)	0-210	0-330
2" (50mm)	0-350	0-550
2.5" (63mm)	0-2,000	0-3,150
3" (80mm)	0-770	0-1,210
4" (100mm)	0-1,330	0-2,100
6" (150mm)	0-3,000	0-4,730

**NOTE!** Standard conditions of air at 70°F and one atmosphere. Consult factory for other gases and for flow ranges above those listed. Inline meters above 5,000 SCFM (7,900 NM<sup>3</sup>/H) air may require third party calibration. Contact Fox Thermal.

## Appendices

Gas Pressure (maximum):

Insertion: 740 psig

316 SS inline meter with NPT ends: 500 psig

316 SS inline meter with 150 lb. flanges: 230 psig

316 SS inline meter with 300 lb. flanges: 600 psig

Carbon steel inline meter with 150 lb. flanges: 285 psig

Carbon steel inline meter with 300 lb. flanges: 740 psig

Retractor Assembly: 150 psig

Check with factory for higher pressure options.

**NOTE!** When teflon ferrule option ordered, gas pressure is 60 psig (4.1 barg) maximum

**NOTE!** Pressure ratings stated for temperature of 100°F (38°C).

Relative Humidity: Non-condensing

**NOTE!** Condensing liquids contacting the sensor can cause erratic flow indication.

Temperature:

DDC-Sensor™: -40 to 250°F (-40 to 121°C)

Enclosure: -40 to 158°F (-40 to 70°C)\*

\***NOTE!** Display dims below -4°F (-20°C), function returns once temperature rises again.

Input Power: 12 to 28VDC, 6 watts minimum

Full Input Power Range: 10 to 30VDC.

A 20 Watt or greater power supply is recommended to power the FT4A.

Outputs:

Channel 1:

Standard isolated 4-20mA output configured to indicate either flow or temperature; fault indication per NAMUR NE43.

The 4-20mA load resistance must be 125 ohms or less when operating on 12 volt power and 600 ohms or less on 24 volt power.

HART communication option

Channel 2:

FT4A can be ordered with either the pulse output or serial communication option.

- Pulse option: Isolated open collector output rated for 5 to 24VDC, 20mA maximum load, 0 to 100Hz (the pulse output can be configured to either transmit a 0 to 100Hz signal proportional to flow rate or an on/off alarm).
- Serial communication option: Isolated RS485 Modbus RTU.

USB Communication:

Isolated USB 2.0 Mini-B for interfacing with a laptop or computer is standard.

FT4A View™: A free PC-based software tool that provides complete configuration, remote process monitoring, and data logging functions through USB communication.

4-20mA and Pulse Verification:

Simulation mode used to align 4-20mA output and pulse output (if ordered) with the input to customer's PLC/DCS.

## Appendices

---

### Physical Specs

Sensor material:  
316 stainless steel

Enclosure:  
NEMA 4, aluminum, dual ¾" FNPT conduit entries

Flow Meter Installation:  
Fox Thermal-supplied compression fitting connects to customer-supplied 1" female coupling welded to pipe.

### Agency Approvals

CE Mark: Approved  
EMC Directive; 2014/30/EU  
Emissions and Immunity Testing: EN61326-1:2013  
Pressure Equipment Directive: 97/23/EC  
Weld Testing: EN ISO 15614-1 and EN ISO 9606-1, ASME B31.3

FM (FM16US0005X) and FMc (FM16CA0005X): Approved  
Class I, Division 1, Groups B,C,D;  
Class II, Division 1, Groups E,F,G;  
Class III, Division 1; T4, Ta = - 40°C to 70°C;  
Class 1, Zone 1, AEx/Ex db IIB + H2 T4; Gb Ta= -40°C to 70°C;  
Type 4X, IP66/67

ATEX (FM16ATEX0013X): Approved  
II 2 G Ex db IIB + H2 T4; Gb Ta = - 40°C to 70°C; IP66/67  
II 2 D Ex tb IIIC T135°C; Db Ta = - 40°C to 70°C; IP66/67

IECEX (IECEX FMG 16.0010X): Approved  
Ex db IIB + H2 T4; Gb Ta = - 40°C to 70°C; IP66/67  
Ex tb IIIC T135°C; Db Ta = - 40°C to 70°C; IP66/67

ATEX and IECEX Standards:

EN 60079-0: 2012 + A11:2013	IEC 60079-0: 2011
EN 60079-1: 2014	IEC 60079-1: 2014
EN 60079-31: 2014	IEC 60079-31: 2013
EN 60529:1991 + A1: 2000	IEC 60529: 2001

# Appendices

Fig. 7.1 Dimensions, Insertion Meter  
Measurements shown in inches (millimeters).

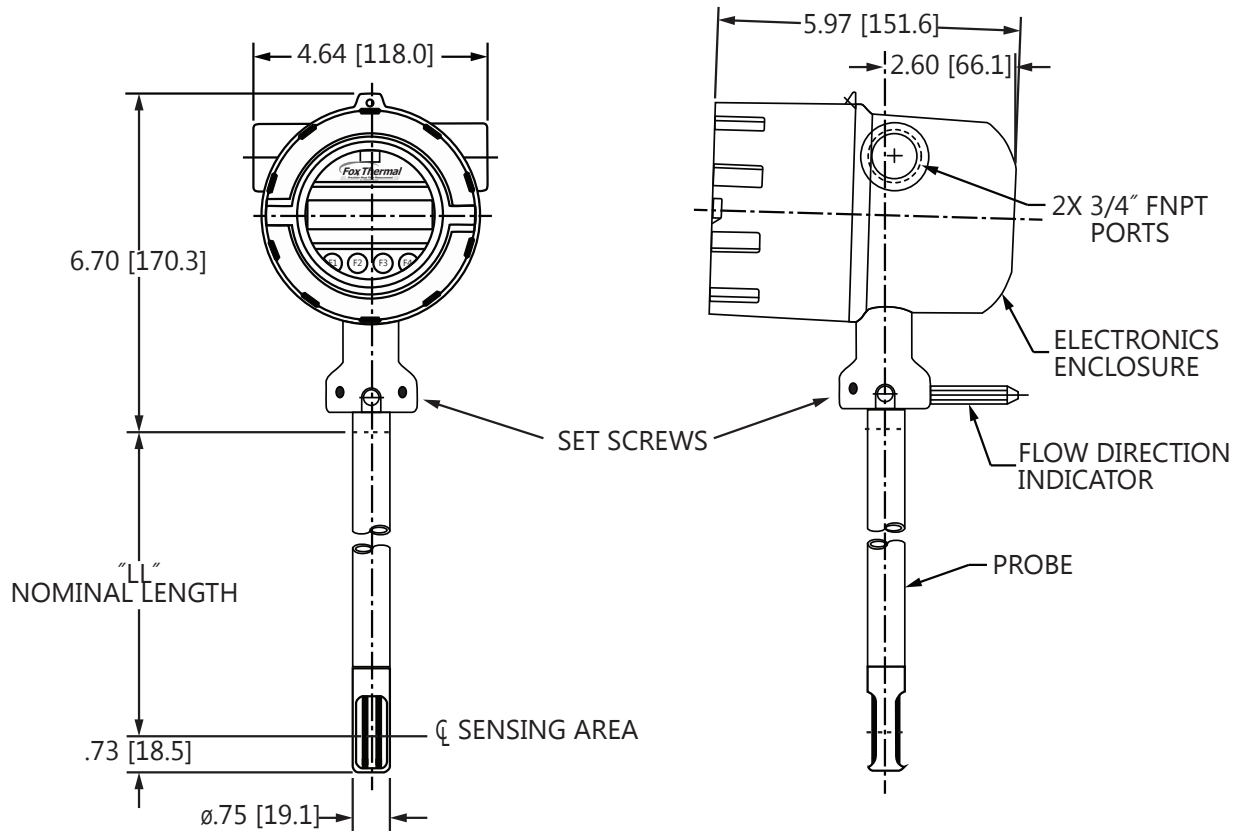

Table 7.1 Insertion Meter with 316 stainless steel probe

Probe Size [model code]	Probe Size [inches]	Dimension "LL" [inches / millimeters]
06I	6"	6.0" (152 mm)
09I	9"	9.0" (229 mm)
12I	12"	12.0" (305 mm)
15I	15"	15.0" (381 mm)
18I	18"	18.0" (457 mm)
24I	24"	24.0" (610 mm)
30I	30"	30.0" (762 mm)
36I	36"	36.0" (914 mm)

# Appendices

Fig. 7.2 Dimensions, Insertion Meter with Retractor  
Measurements shown in inches (millimeters).

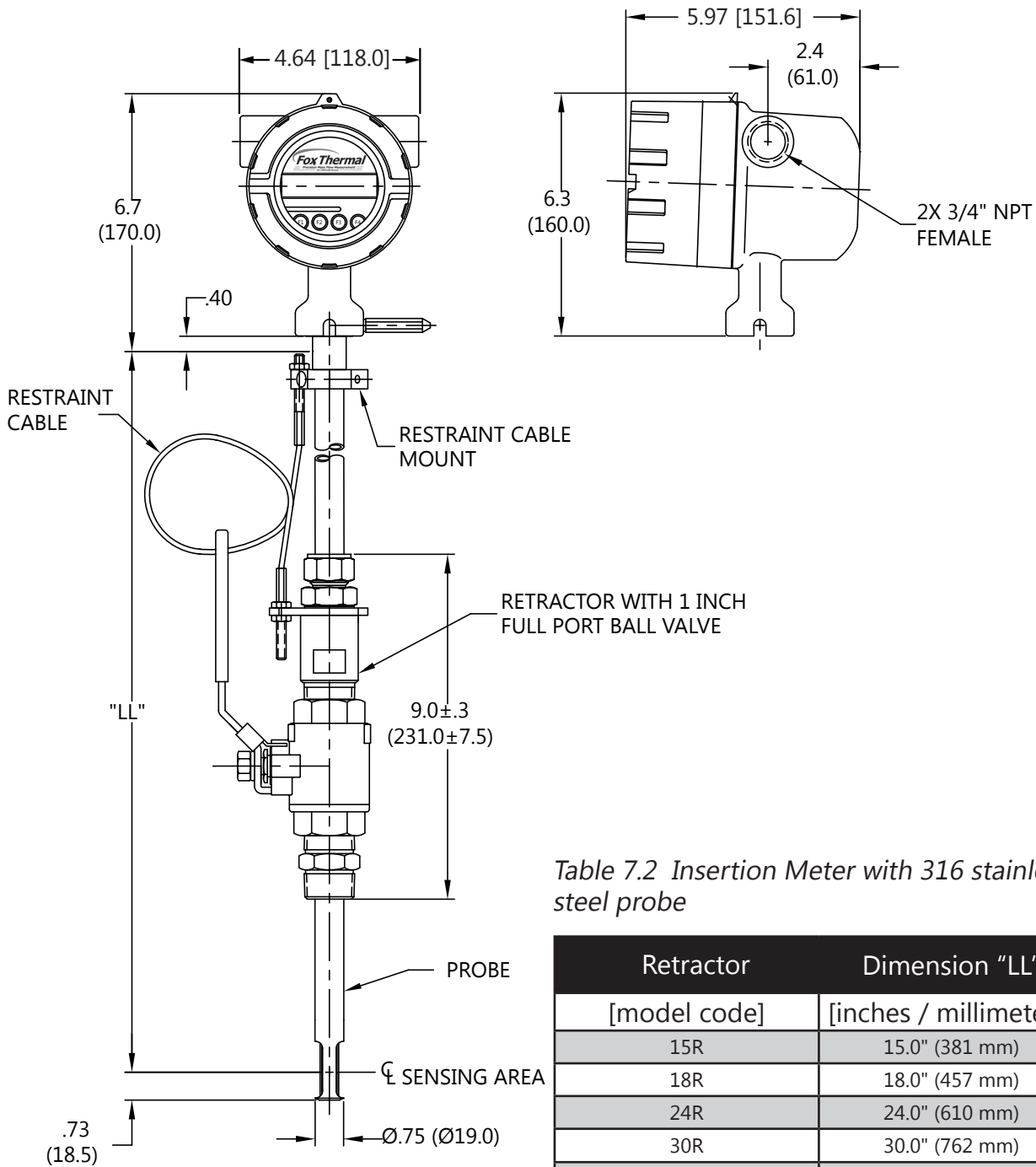

Table 7.2 Insertion Meter with 316 stainless steel probe

Retractor [model code]	Dimension "LL" [inches / millimeters]
15R	15.0" (381 mm)
18R	18.0" (457 mm)
24R	24.0" (610 mm)
30R	30.0" (762 mm)
36R	36.0" (914 mm)

# Appendices

Fig. 7.3 Dimensions, Inline Meter with Flow Body and NPT End Connections  
Measurements shown in inches (millimeters).

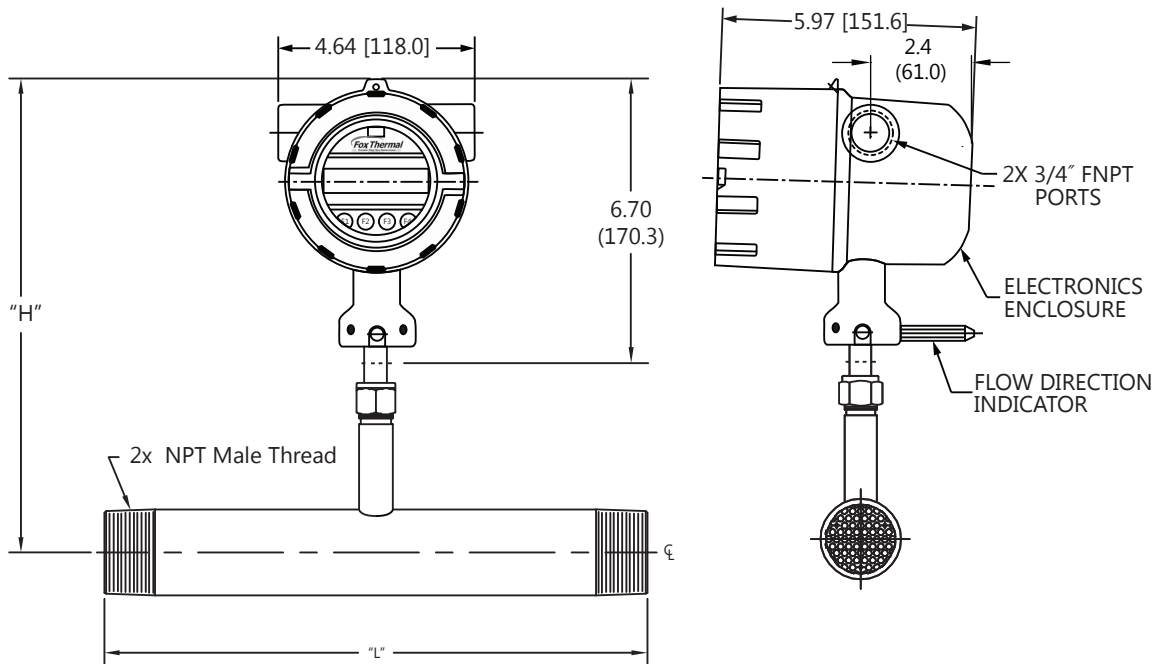

Table 7.3 Inline Meter with Flow Body and NPT End Connections

Body Size [model code]	Body Size [inches]	Dimension "L" [inches]	Dimension "H" [inches / millimeters]
075P *	0.75"	12"	10.7" (271.8mm)
10P *	1.00"	12"	10.7" (271.8mm)
125P *	1.25"	12"	10.7" (271.8mm)
15P *	1.50"	12"	12.7" (322.6mm)
20P **	2.00"	12"	12.7" (322.6mm)
25P **	2.50"	18"	12.7" (322.6mm)
30P **	3.00"	18"	12.7" (322.6mm)

\*available in 316 Stainless Steel only

\*\*available in 316 Stainless Steel or A106 Grade B Carbon steel pipe

# Appendices

Fig. 7.4 Dimensions, Inline Meter with 3 Flow Body and 150# RF Flange End Connections Measurements shown in inches (millimeters).

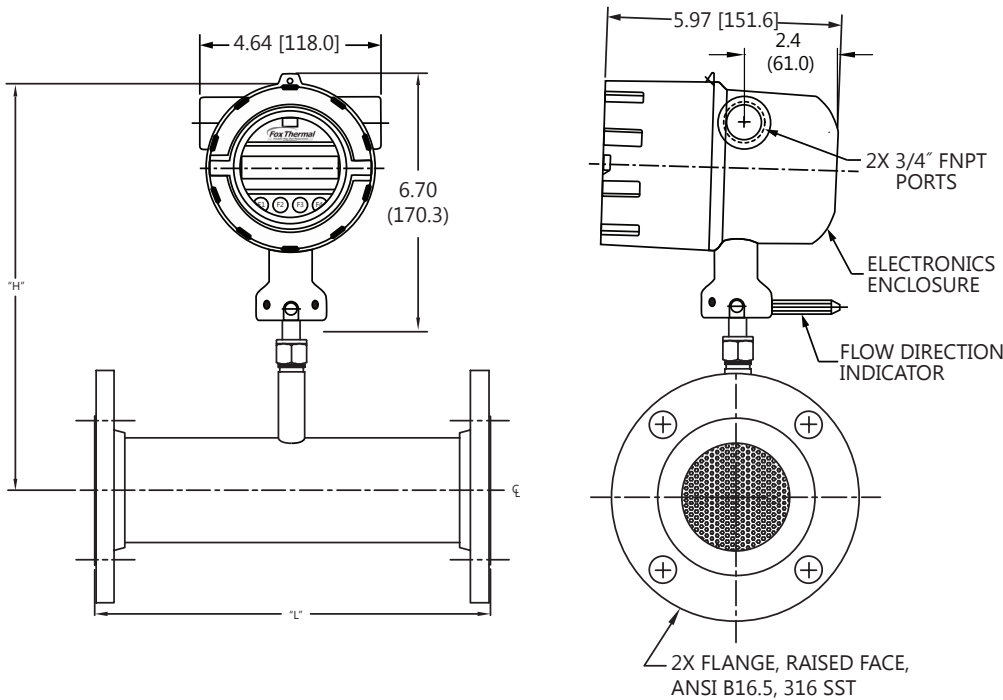

Table 7.4 Inline Meter with Flow Body and 150# RF Flange End Connections Dimensions

Body Size [model code]	Body Size [inches]	Dimension "L" [inches]	Dimension "H" [inches / millimeters]
075F *	0.75"	12"	10.7" (271.8mm)
10F *	1.00"	12"	10.7" (271.8mm)
125F *	1.25"	12"	10.7" (271.8mm)
15F *	1.50"	12"	12.7" (322.6mm)
20F **	2.00"	12"	12.7" (322.6mm)
25F **	2.50"	18"	12.7" (322.6mm)
30F **	3.00"	18"	12.7" (322.6mm)
40F **	4.00"	18"	12.7" (322.6mm)
60F *	6.00"	24"	12.7" (322.6mm)

\*available in 316 Stainless Steel only

\*\*available in 316 Stainless Steel or A106 Grabe B Carbon steel pipe + A105 Flanges

# Appendices

Fig. 7.5 Dimensions, Inline Meter with Flow Body and 300# RF Flange End Connections  
Measurements shown in inches (millimeters).

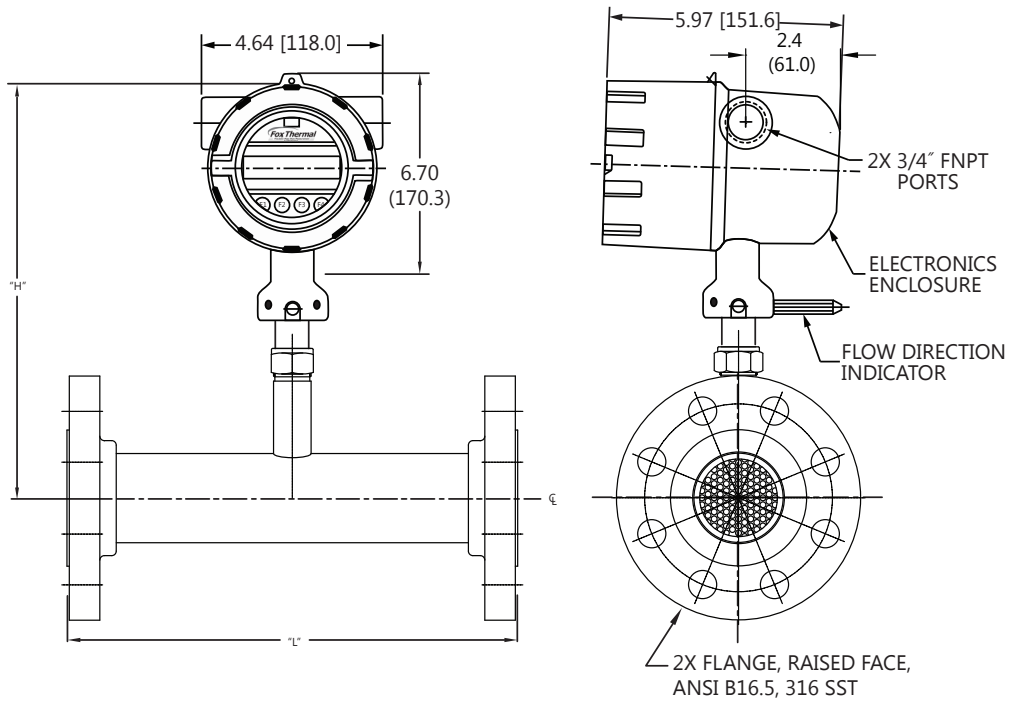

Table 7.5 Inline Meter with Flow Body and 300# RF Flange End Connections Dimensions

Body Size [model code]	Body Size [inches]	Dimension "L" [inches]	Dimension "H" [inches / millimeters]
15F *	1.50"	12"	10.7" (271.8mm)
20F **	2.00"	12"	10.7" (271.8mm)
25F **	2.25"	18"	12.7" (322.6mm)
30F **	3.00"	18"	12.7" (322.6mm)
40F **	4.00"	18"	12.7" (322.6mm)
60F *	6.00"	24"	12.7" (322.6mm)

\*available in 316 Stainless Steel only

\*\*available in 316 Stainless Steel or A106 Grade B Carbon steel pipe + A105 Flanges



## Appendices

---

### Warranty

(a) Fox Thermal Instruments, Inc. (Fox Thermal) warrants that the products furnished under this Agreement will be free from defects in material and workmanship for a period of one year from the date of shipment. The customer shall provide notice of any defect to Fox Thermal, within one week after the Customer's discovery of such defect. The sole obligation and liability of Fox Thermal, under this warranty shall be repair or replace, at its option, without cost to the Customer, the defective product or part.

(b) Upon request by Fox Thermal, the product or part claimed to be defective shall immediately be returned at the Customer's expense to Fox Thermal. Replaced or repaired products or parts will be shipped to the Customer at the expense of Fox Thermal. Fox Thermal shall have the right of final determination as to the existence and cause of defect.

(c) There shall be no warranty or liability for any products or parts that have been subject to misuse, accident, negligence, failure of electric power or modifications by the Customer without the written approval of Fox Thermal. Final determination of warranty eligibility shall be made by Fox Thermal. If a warranty claim is considered invalid for any reason, the Customer will be charged for services performed and expenses incurred by Fox Thermal, in handling and shipping the returned unit.

(d) The liability of Fox Thermal shall be limited to replacing or repairing, at its option, any defective parts which are returned. Labor and related expenses incurred to install replacement parts are not covered by this warranty.

(e) As to replacement parts supplied or repairs made during the original warranty period, the warranty period for the replacement or repaired part shall terminate with the termination of the warranty period of the original product or part.

(f) The use of these products is under exclusive control of the purchaser and Fox Thermal specifically denies any responsibility for the calibration of units and/or accuracy of work performed or the safety of the system in which Fox Thermal products is used. EXTERNAL SAFETY DEVICES MUST BE USED WITH THIS EQUIPMENT.

(g) No warranty is made with respect to custom equipment or products produced to Buyer's specifications except as specifically stated in writing by Fox Thermal and contained in the agreement.

(h) THE FOREGOING WARRANTY CONSTITUTES THE SOLE LIABILITY OF FOX THERMAL, AND THE CUSTOMER'S SOLE REMEDY WITH RESPECT TO THE PRODUCTS AND IS IN LIEU OF ALL OTHER WARRANTIES, INCLUDING ANY WARRANTY OF MERCHANTABILITY OR FITNESS FOR A PARTICULAR PURPOSE, LIABILITIES, AND REMEDIES. EXCEPT AS THUS PROVIDED, FOX THERMAL, DISCLAIMS ALL WARRANTIES, EXPRESS OR IMPLIED, INCLUDING ANY WARRANTY OF MERCHANTABILITY OR FITNESS FOR A PARTICULAR PURPOSE.

## Appendices

---

### Returning Your Meter

The Fox Thermal Customer Service Department (PH: 831- 384-4300 or FAX: 831-337-5787) can help you through the process of returning a meter for service.

If it becomes necessary to return a Fox Thermal flow meter for service or recalibration, please follow these steps:

1. A Return Material Authorization (RMA) Number must be obtained from the Fox Thermal Customer Service Department prior to returning any Fox Thermal meter(s).
2. Please have your meter's serial number(s) available.
3. Read and complete the Fox Thermal RMA Customer Information Form. Be sure to initial the decontamination statement as well as provide complete return shipping instructions (we cannot deliver to post office boxes).
4. The entire flow meter must be returned, including all electronics (unless specifically instructed to do otherwise). **ALL** serial numbers must match their corresponding meters. This is especially necessary when returning flow body models.
5. Clean and decontaminate all wetted parts before returning to Fox Thermal.
6. Ship the meter to the following address:

Fox Thermal Instruments, Inc.  
399 Reservation Road  
Marina, CA 93933  
Attn: Service Dept.  
[RMA Number]



**NOTE!** Be sure to review all of the information on the Customer Information Form before sending your meter to the Fox Thermal Customer Service Department. The Fox Thermal Shipping/Receiving Department cannot accept meters that have not been prepared appropriately.

## Appendices

---

### **What to expect while your meter is being serviced**

Depending on the type of service required when returning your Fox Thermal meter, there are varying turnover times for servicing a meter. The average time needed to service the meter is 7-10 days (not including shipping or peak production times).

If you have already shipped your meter to Fox Thermal for servicing and would like to check the status of your meter, please fill out our online Service Order Status form located at [www.foxthermal.com](http://www.foxthermal.com) and you will hear from a Customer Service Rep within 1 business day of your requested update.

Rush recalibration service is available for a fee. Restrictions apply.

**Glossary of Terms and Definitions**

AWG	American Wire Gauge	NLPH	Normal Liter per Hour
Bara	Bar absolute	NLPM	Normal Liter per Minute
CTC	Contact	NM3	Normal cubic Meter
CAL	Calibration	NM3/H	Normal cubic Meter per Hour
CHG	Change	NM3/M	Normal cubic Meter per Minute
COM	Communication	NPT	National Pipe Thread
CSV	Current Sense Voltage	PDA	Personal hand held computer
DC	Direct Current	PC	Personal Computer
DN	Down	P/U	Pulse per Unit
DSP	Display	PIP A <sup>2</sup>	Pipe Area
ELP	Elapsed time	PLC	Programmable Logic Controller
Feq	Frequency	PRM	Parameters
Ft <sup>2</sup>	Square Feet	PRS	Pressure
I/O	Input/Output	PSIA	Pounds per Square Inch Absolute
INP	Input	Pt	Point
LB	Pound	PSW	Password
LB/D	Pound per Day	SIM	Simulation
LB/H	Pound per Hour	SCF	Standard Cubic Feet
LB/M	Pound per Minute	SCFM	Standard Cubic Feet per Minute
LB/S	Pound per Second	SCFH	Standard Cubic Feet per Hour
LCD	Liquid Crystal Display	SCFD	Standard Cubic Feet per Day
KG	Kilogram	SPC	Special Control
KG/H	Kilogram per Hour	STP	Standard Temperature and Pressure
KG/M	Kilogram per Minute	TMP	Temperature
KG/S	Kilogram per Second	TSI	Internal Variable
M <sup>2</sup>	Square Meter	TSV	Internal Variable
mmHG	Pressure in millimeters of mercury	UNT	Unit
MMSCFD	Million Standard Cubic Feet/Day	U/P	Unit per Pulse
MXFLO	Maximum Flow	420	4-20mA output
NEMA	National Electrical Manufactures Association		
NIST	National Institute of Standards and Technology		
NL	Normal Liter		

# Appendices

## Index

- Access to Electronics, p. 23
- Alarm Codes, p. 88
- Alarm wiring, p. 33
- Analog 4-20mA output, p. 41
- Breakage or Damage of Probe, p. 79
- Dimension Details, p. 92
- Discrete output setting, p. 45
- Display Screens, p. 39
- Display Setup, p. 46
- Entering the programming mode, p. 40
- Filter value, p. 52
- Flow Meter Placement, p. 19
- Flow Units, p. 48
- Pulse/alarm Output, p. 43
- Fuse Replacement, p. 79
- Glossary, p. 100
- Installation,
  - Compression Fitting - Insertion, p. 29
  - General Precautions, p. 18
  - Lateral Placement, p. 19
  - Mounting, p. 19
  - Meter Orientation - Insertion, p. 22
- Introduction, p. 15
- K Factor, p. 53
- Level 2 password, p. 48
- Local Display, p. 16
- Local Input Wiring, p. 30
- Logs, p. 11
- Mass Flow, p. 15
- Measurement Mode, p. 39
- Menu Tree,
  - Digital Output, p. 5
  - Display Menu, p. 8
  - Gas-SelectX®, p. 10
  - Main Menu, p. 4
  - Flow Menu 1, p. 6
  - Flow Menu 2, p. 7
  - CAL-V® Menu, p. 9
- Mounting meter, p. 19
- Orientation of meter - Insertion type, p. 22
- Password
  - Level 1, p. 48
  - Level 2, p. 48
  - Programming, p. 48
- Power Input Wiring, p. 30
- Preventative Maintenance, p. 79
- Product Description, p. 15
- Programming
  - Analog 4-20mA Output, p. 41
  - Alarm Output, p. 45
  - Changing values or strings, p. 40
  - Display Setup, p. 46
  - Filter value, p. 52
  - Flow cutoff, p. 51
  - Flow Parameters, p. 51
  - Flow and maximum pulse/alarm, p. 44
  - High Alarm Limit value, p. 52
  - Pulse/alarm Output, p. 43
  - K Factor, p. 53
  - Low Alarm Limit value, p. 52
  - Password, p. 48
  - Pipe Diameter, p. 52
  - Programming Mode, p. 40
  - Pulse-per-unit, p. 44
  - Restore Database, p. 54
  - Reset CRC, p. 54
  - Reset Total/Elapsed Time, p. 56
  - Selecting from a list, p. 40
  - Serial Communication, p. 46
  - Simulation, p. 55
  - Unit-per-pulse, p. 44
  - Unit settings, p. 48
  - Using the Local Display, p. 40
- Replacements Fuses, p. 79
- Restore Database, p. 54
- Reset Total/Elapsed Time, p. 56
- Return Procedure, p. 98
- Sensor Cleaning, p. 79
- Sensor Orientation, p. 22
- Simulation Mode, p. 55
- Theory of Operation, p. 15
- To program the display, p. 47
- Totalizer Rollover, p. 55
- Troubleshooting, p. 84
  - Alarm Codes, p. 88
  - Installation Problems, p. 87
- USB Interface, p. 38
- Warranty, p. 97
- Wiring
  - Alarms, p. 33
  - Pulse/Alarm Outputs, p. 33
  - Grounding, p. 29
  - Input - Local, p. 30
  - Instructions, p. 29
  - Local meters, p. 30
  - Power Input, p. 30
  - Precautions, p. 29



## Wiring



## Definition of Terms



## Troubleshooting Tips



## Notes and Information



**WARNING!** is used to indicate a hazardous situation which, if not avoided, could result in death or serious injury.



**CAUTION!** is used to indicate a hazardous situation which, if not avoided, could result in minor or moderate injury.



Indicates compliance with the WEEE Directive. Please dispose of the product in accordance with local regulations and conventions.



Indicates compliance with the applicable European Union Directives for Safety and EMC (Electromagnetic Compatibility Directive 2014/30/EU).