

NELES® SOFT SEATED BALL VALVES, SEAT SUPPORTED, FULL AND REDUCED BORE, SERIES X

Metso's Neles® series X is a seat supported modular ball valve. Neles X series valves incorporate robust stem to ball connection. This assures valves are delivering solid long lasting performance in high cycle isolation and control applications. Application based seat selection assures valves are capable of delivering long lasting tightness even in most demanding applications. Valve modularity widens the options in material selections to meet application specific requirements. Valve series meets modern industry requirements concerning safety and emissions.

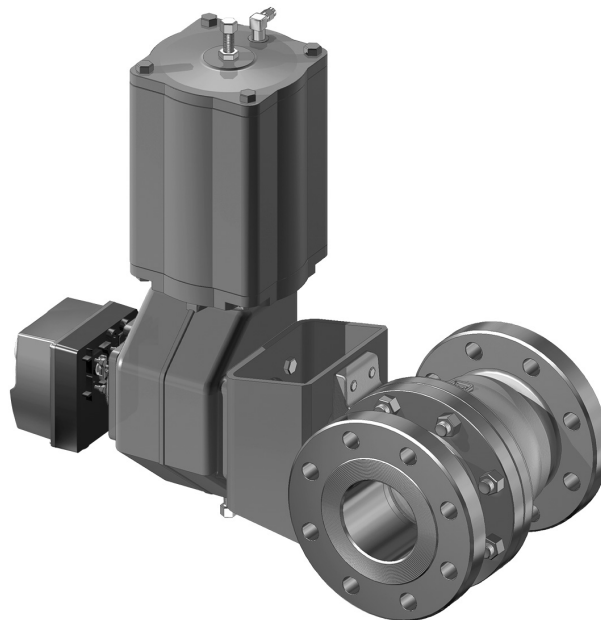

Applications

- Chemical and petrochemical plants
- Oil and gas production
- Power plants
- Other process industry applications
- Liquids, gas and steam
- Hydrocarbons
- Moderate control and tight shut-off applications
- Emergency valves ESD/ESV
- LNG

Size range

- 1" – 8" / DN 25 – 200, full bore
- 3" – 8" / DN 80 – 200, reduced bore
- For larger sizes, up to 16" / DN 400, see bulletin 1 X 22 for trunnion mounted designs.

Pressure classes

- ASME Class 150 and 300.
- ASME Class 600, see bulletins 1 X 23.

Tightness

- All versions are bubble tight.
- Long life flexible lip seat design that compensates pressure/temperature cycling and wear.

Versions, details

- Live-loaded graphite packing assures long operation and low emission level.
- Spiral wound body joint gasket.
- Long life flexible lip seat design that compensates pressure / temperature cycling and wear.
- Spline driver connection for reliable torque transmission.
- Fire tested API 607.
- Trunnion mounted versions – see bulletin 1 X 22.

Full bore

- Maximum Cv per nominal size.
- Cylindrical flow path allows low flow resistance.
- Full bore design for API requirements.

Minimized emissions

- Live-loaded gland packing.
 - ISO 15848 with graphite packing
 - TA-Luft with graphite packing.
 - Clean Air Act.
- Off-center body joint, sizes 1" - 8" full bore, in reduced bore version only in size 8".
 - Uninterrupted circular spiral wound body gasket.
 - No bending forces to gland packing.
- One piece body in sizes 3" - 6", reduced bore.

EXPLODED VIEW

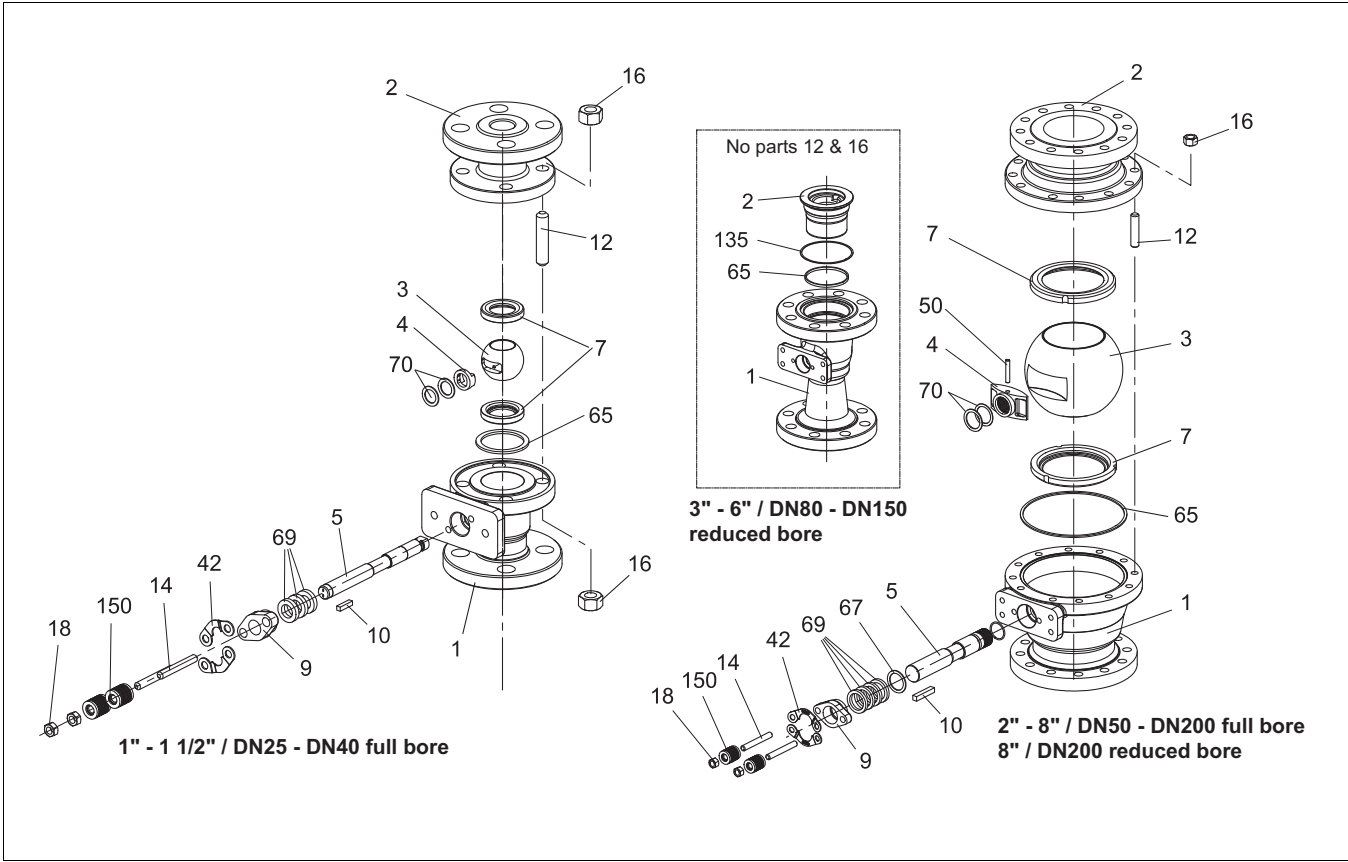

PARTS LIST

Item	Part description	Material	
1	Body	Stainless steel CF8M	Carbon steel WCB
2	Body cap	Stainless steel CF8M / AISI 316	Carbon steel WCB
	Insert 3" - 6" / DN80 - 150 reduced bore	CF8M	AISI 410
3	Ball	Stainless steel AISI 316 / CF8M	
4	Spline driver 2" - 8" / DN 50 - 200	Stainless steel CF8M	
	Thrust ring 1" - 1 1/2" / DN25 - 40	AISI 316	
5	Shaft	Stainless steel XM-19	
7	Ball seat	Xtreme®	
9	Gland	Stainless steel CF8M	
10	Key	Stainless steel AISI 329	
12	Stud (not in reduced bore 3" - 6" / DN80 - 150)	ASTM A 193 gr. B8M	ASTM A 320 gr. L7M (B7)
14	Stud	ASTM A 193 gr. B8M	ASTM A 320 gr. L7M (B7)
16	Hexagon nut (not in reduced bore 3" - 6" / DN80 - 150)	ASTM A 193 gr. 8M	ASTM A 194 gr. 2 HM (2H)
18	Hexagon nut	ASTM A 193 gr. 8M	ASTM A 194 gr. 2 HM (2H)
42	Retainer plate	Stainless steel AISI 316	
50	Locking pin	Stainless steel XM-19	
65	Body gasket	Stainless steel AISI 316 + PTFE or graphite filled spiral wound	
67	Thrust ring	Stainless steel AISI 316	
69	Packing ring	PTFE or graphite	
70	Thrust bearing	Cobalt based alloy or filled PTFE	
135	Gasket (only in reduced bore 3" - 6" / DN80 - 150)	Graphite or PTFE	
150	Disc spring set	Electroless nickel plated spring steel (EN 10083-1.8159)	

TECHNICAL SPECIFICATION

Product type

Full and reduced bore, seat supported ball valve
Floating ball design
Split body design

Pressure ratings

ASME 150 and 300

Size range

1" – 8" / DN 25 – 200, full bore
3" – 8" / DN 80 – 200, reduced bore

Temperature range

-50 °C...+260 °C / -60 °F...+500 °F

Design standards

Valve body ASME B16.34
Valve flanges ASME B16.5
Face-to-face ASME B16.10 long pattern, full bore
ASME B16.10 short pattern, reduced bore
Actuator mounting ISO 5211

Standard materials

Body: WCB and CF8M
Ball: CF8M
Bearings: PTFE
Seats: Xtreme®
Seals/gaskets: PTFE or graphite
Body gasket: spiral wound with PTFE or graphite filler
Gland packing: PTFE (V-rings) or graphite
Bolting: L7M/2HM or B8M/8M.

Material and test certification

EN 10204-3.1 material certificates for body and bonnet.
Tightness test certificate.

Standard options

Anti-static
Degreasing
Fire tested API 607
NACE MR 0103 as standard
NACE MR 0175 available on request

Valve testing

Each valve is tested for body integrity and seat tightness.
The body test pressure is 1.5 x PN. The seat test pressure for metal seated valves is 1.1 x PN.
The test medium is inhibited water. Air test upon request.

Valve tightness

All versions are bubble tight.

C_v (K_v) -values and resistance coefficients, full bore

Valve size inch / DN	Standard trim			Q-TRIM	
	Cv 90°	Kv 90°	ζ 90°	Cv 90°	Kv 90°
1" / 25	105	91	0.08	–	–
1 1/2" / 40	250	220	0.07	–	–
2" / 50	490	425	0.06	84	73
3" / 80	1160	1000	0.05	245	210
4" / 100	2200	1900	0.05	530	460
6" / 150	5100	4400	0.04	1360	1180
8" / 200	9300	8000	0.04	2330	2020

C_v (K_v) -values and resistance coefficients, reduced bore

Valve size Inch / DN	Standard trim			Q-TRIM	
	Cv 90°	Kv 90°	ζ 90°	Cv 90°	Kv 90°
3 / 80	234	202	1.6	84	73
4 / 100	666	576	0.5	245	212
6 / 150	1022	884	1.0	530	458
8 / 200	2665	2305	0.5	1360	1176

THE ADVANTAGES OF THE SPLINE DRIVER

This unique design allows for a larger shaft to ball interface which in turn, minimizes the contact stress. Such a feature results in:

- excellent operational durability
- maximized torque transmission
- accurate operation,
- minimized mechanical backlash

For the end-user, these technical advantages offer longer valve life, less maintenance, more economical and safer processes.

The spline driver construction is available in valve sizes 2" - 8" / DN50 - 200.

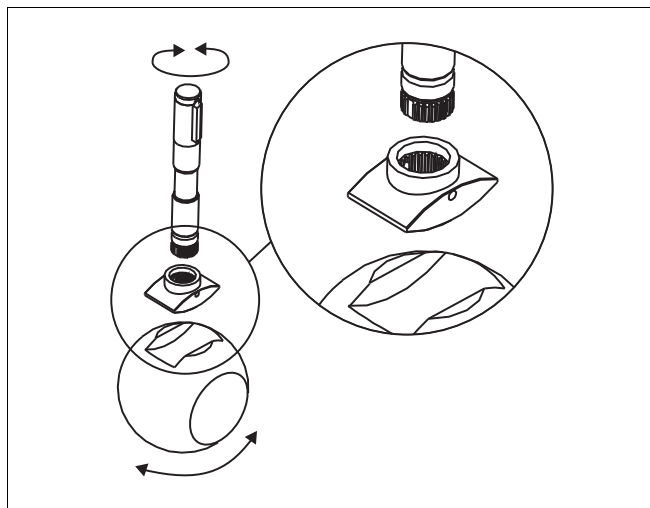

SEAT DESIGN

Soft seat X, for general use



1" – 8" / DN 25 – 200, full bore
3" – 8" / DN 80 – 200, reduced bore

Material: Xtreme®
Temperature range: -50 °C ...+260 °C / -60 °F...+500 °F

VALVE SEAT RATING, SOFT SEATS

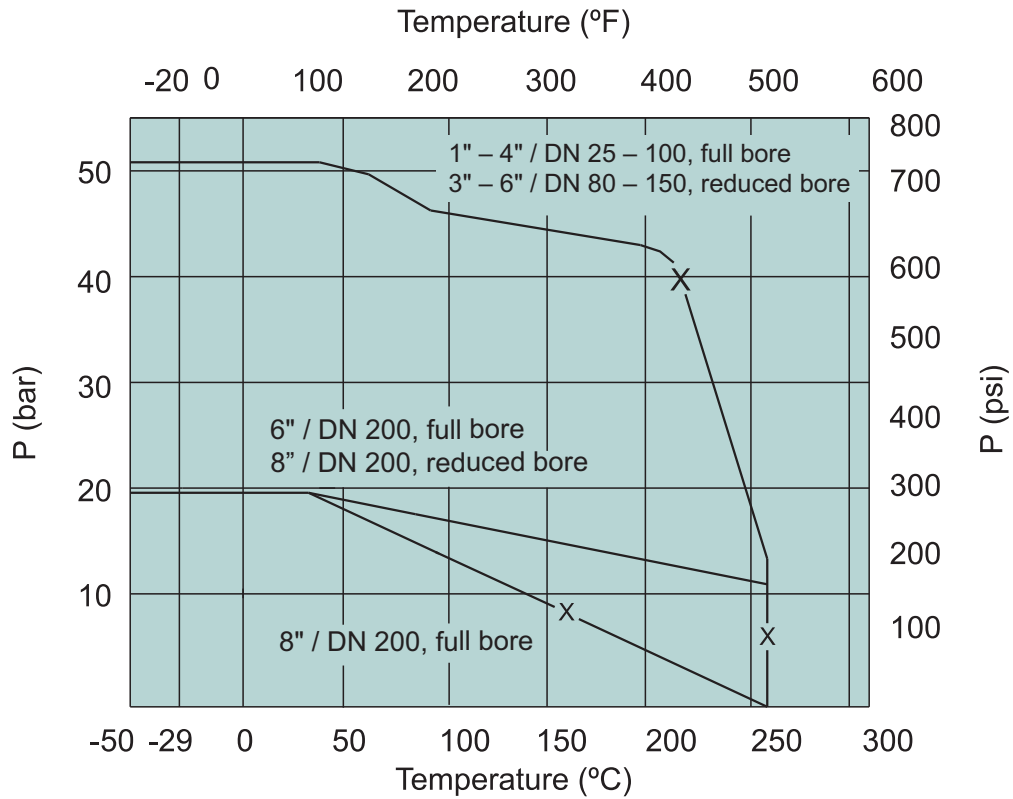

BODY PRESSURE/TEMPERATURE RATING, ASTM A351 gr.CF8M

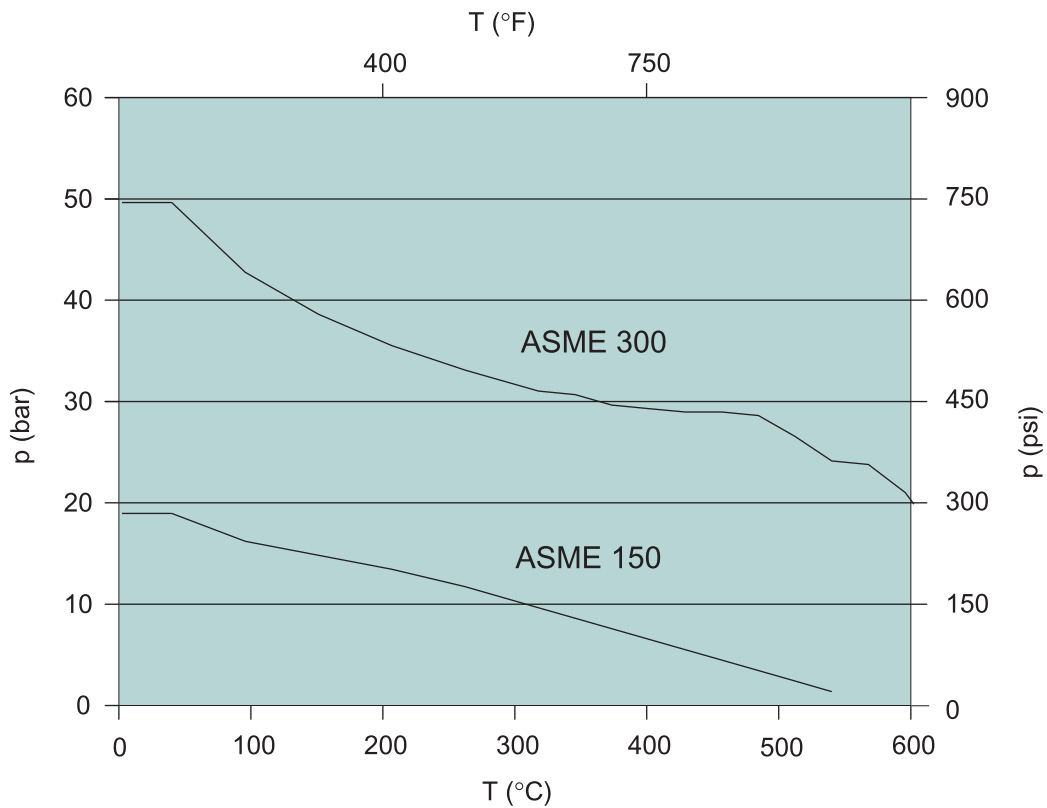

BODY PRESSURE/TEMPERATURE RATING, ASTM A216 gr.WCB

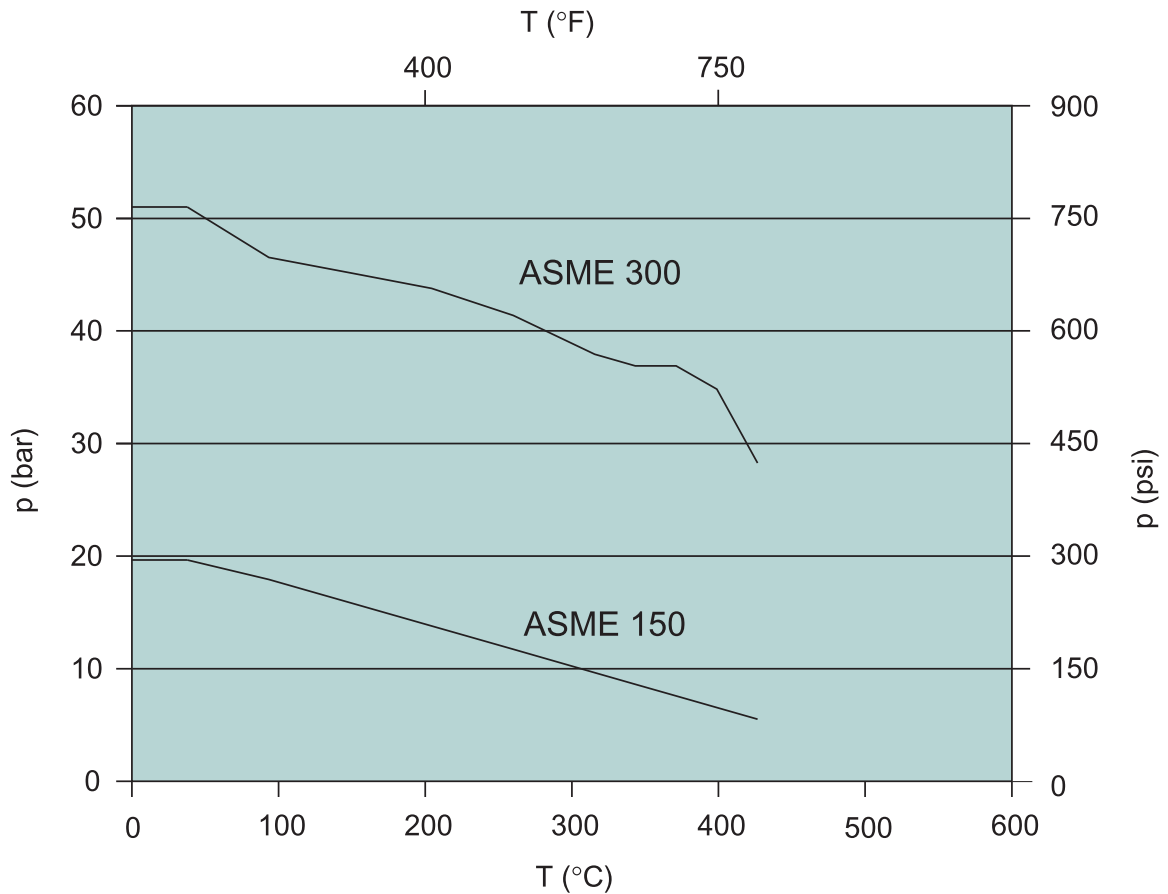

ACTUATOR SELECTION

X-series valve can be equipped with the following Metso actuator types:

B1C/B1J Pneumatic double acting or spring return actuator.
Actuators available for size range DN 25 - 200 / 1"-8", B1C/B1J actuators have an ISO 5211 mounting face.

M Gear operator for valve sizes DN 25-200 / 1"-8".

LX/LK Hand lever for valve sizes DN 25-100 / 1"-4".

When selecting other actuators, please contact your local Metso representative.

For the correct actuator selection in on-off service, you need to know the following process data:

- valve size and seat type
- supply pressure for the actuator
- maximum shut-off pressure across the valve

DIMENSIONS, FULL BORE

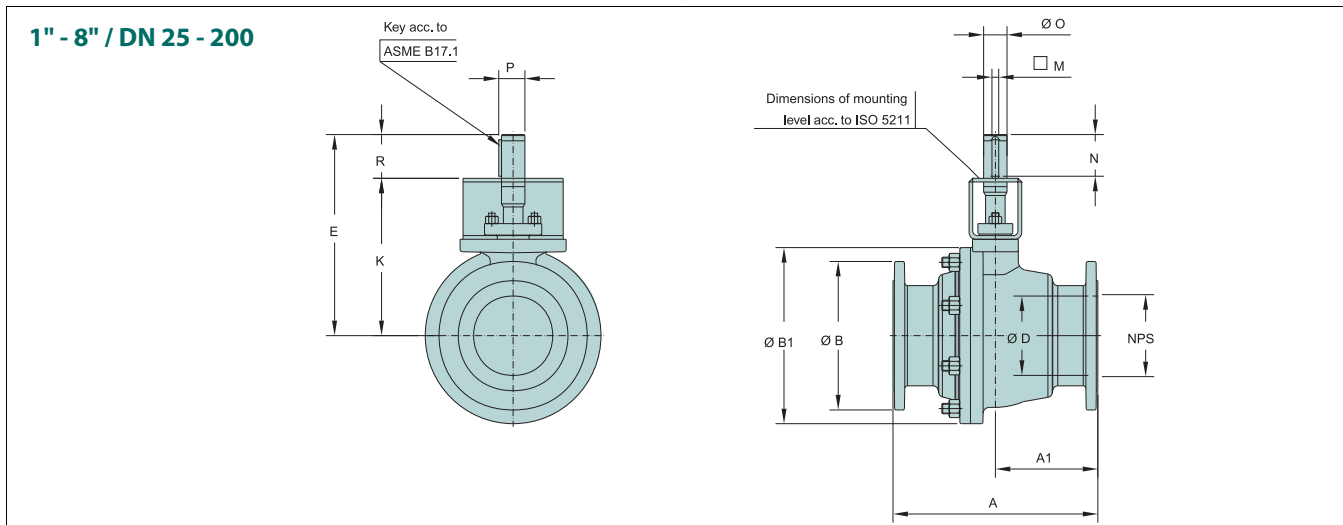

TYPE	SIZE	ISO FLANGE	DIMENSIONS, mm												kg
			A	A1	ØB	ØB1	ØD	E	K	M	N	ØO	P	R	
XT_C	1	F07	165	74	110	110	25.4	175	150	4.76	25	15	17	25	6
	1.5	F07	165	70	125	145	38.1	202	168	4.76	35	20	22	34	8
	2	F07, F10	178	79.0	150	146	50.8	215	168	6.35	46	25	27.8	47	11
	3	F07, F10, F12, F14	203	101.5	190	190	76.2	237	190	6.35	46	25	27.8	47	25
	4	F10, F12, F14	229	110.5	230	241	101.6	309	250	9.52	58	35	39.1	59	39
	6	F14, F16	394	197.0	280	338	152.4	386	305	12.70	80	45	50.4	81	93
8	F14, F16, F25	457	228.5	345	430	203.2	476	385	12.70	90	55	60.6	91	190	
XA_D	1	F07	165	74	125	110	25.4	175	150	4.76	25	15	17	25	7
	1.5	F07	191	70	155	145	38.1	202	168	4.76	35	20	22	34	11
	2	F07, F10	216	89.0	165	146	50.8	215	168	6.35	46	25	27.8	47	15
	3	F07, F10, F12, F14	282	141.0	210	195	76.2	237	190	6.35	46	25	27.8	47	35
	4	F10, F12, 14	305	152.5	255	252	101.6	309	250	9.52	58	35	39.1	59	59
	6	F14, F16	403	201.5	320.0	346	152.4	386	305	12.70	80	45	50.4	81	129
8	F14, F16, F25	502	249.0	380	462	203.2	476	385	12.70	90	55	60.6	91	255	

FACE-TO-FACE DIMENSIONS ACC. TO ASME B16.10
 PRESSURE RATINGS C=ASME 150, D=ASME 300

DIMENSIONS, REDUCED BORE

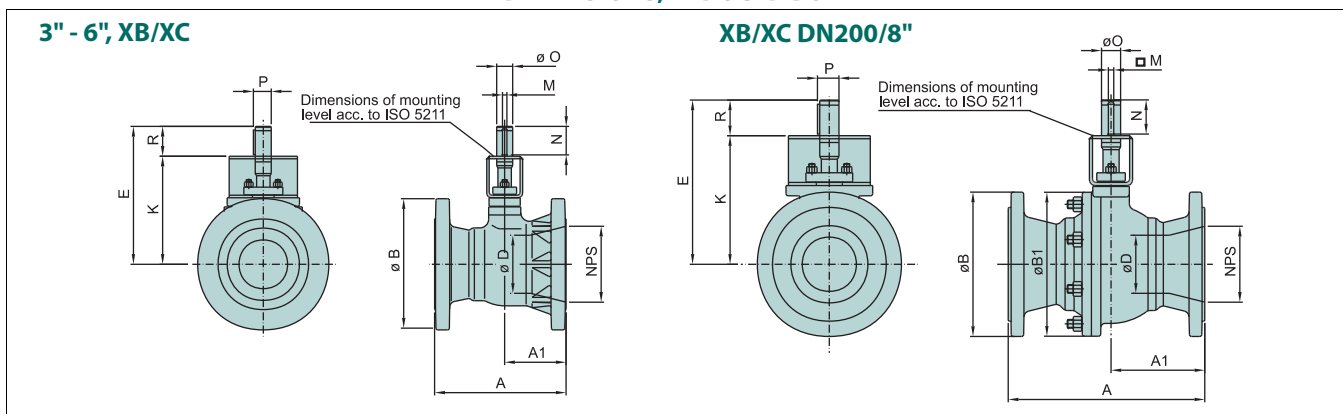

ASME 150

TYPE	SIZE	ISO FLANGE	DIMENSIONS, mm												kg
			A	A1	ØB	ØB1	ØD	E	K	M	N	ØO	P	R	
XB	3	F07, F10	203	100	190	-	50.8	215	168	6.35	46	25	27.8	47	23
	4	F07, F10, F12, F14	229	107	230	-	76.2	237	190	6.35	46	25	27.8	47	34
	6	F10, F12, F14	269	126	280	-	101.6	309	250	9.52	58	35	39.1	59	82
	8	F14, F16	292	135	345	342	152.4	386	305	12.70	80	45	50.4	81	160

ASME 300

TYPE	SIZE	ISO FLANGE	DIMENSIONS, mm												kg
			A	A1	ØB	ØB1	ØD	E	K	M	N	ØO	P	R	
XC	3	F07, F10	283	100	210	-	50.8	215	168	6.35	46	25	27.8	47	31
	4	F07, F10, F12, F14	305	107	255	-	76.2	237	190	6.35	46	25	27.8	47	50
	6	F10, F12, F14	403	126	320	-	101.6	309	250	9.52	58	35	39.1	59	110
	8	F14, F16	419	209.5	380	353	152.4	386	305	12.70	80	45	50.4	81	235

Face to face dimensions acc. to ASME B16.10
 Valve is shown in closed position.

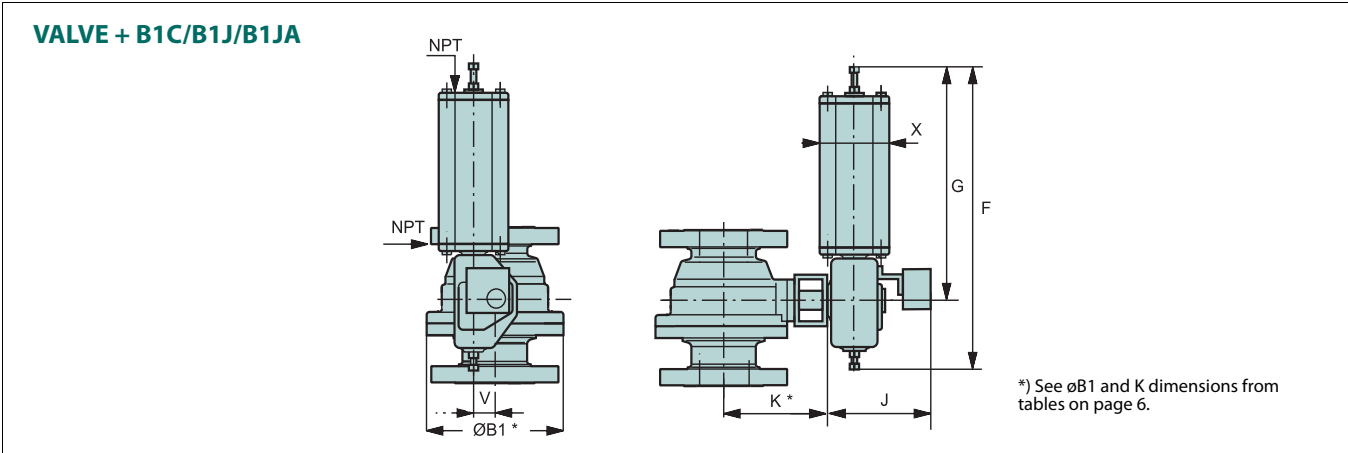

B1C ACTUATOR

Type	DIMENSIONS, mm					NPT	kg
	F	G	J	V	X		
B1C6	395	270	283	36	90	1/4	4.2
B1C9	450	315	279	43	110	1/4	9.6
B1C11	535	375	290	51	135	3/8	16
B1C13	640	445	316	65	175	3/8	31
B1C17	785	555	351	78	215	1/2	54
B1C20	880	590	385	97	215	1/2	73
B1C25	1075	725	448	121	265	1/2	131
B1C32	1370	920	525	153	395	3/4	256
B1C40	1670	1150	595	194	505	3/4	446
B1C50	2060	1390	690	242	610	1	830

B1J/B1JA ACTUATOR

Type	DIMENSIONS, mm					NPT	kg
	F	G	J	V	X		
B1J/B1JA6	485	368	273	36	110	3/8	8
B1J/B1JA8	560	420	279	43	135	3/8	17
B1J/B1JA10	650	490	290	51	175	3/8	30
B1J/B1JA12	800	620	316	65	215	1/2	57
B1J/B1JA16	990	760	351	78	265	1/2	100
B1J/B1JA20	1200	935	358	97	395	3/4	175
B1J/B1JA25	1530	1200	448	121	505	3/4	350
B1J/B1JA32	1830	1410	525	153	540	1	671

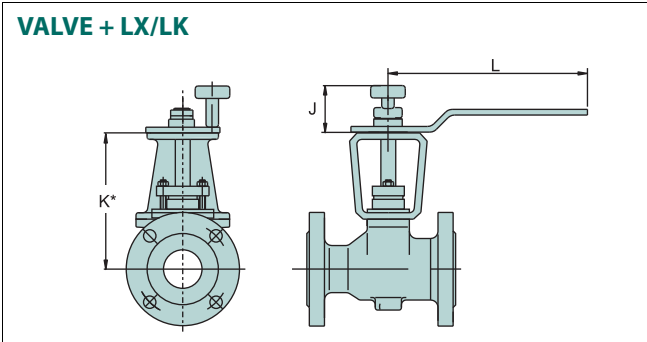

HAND LEVER LX AND LK

DN	Handlever	J	L
25	LX180A	48	180
40	LX220A	53	220
50	LK350	52	350
80	LK350	52	350
80	LK450	52	450
100	LK450	52	450

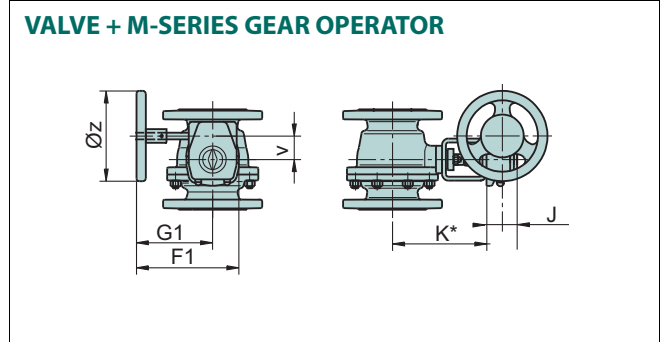

M-SERIES GEAR OPERATOR

Actuator size	F1	G1	J	V	Z	kg
M07	235	184	65	52	160	3.8
M10	238	187	65	52	200	4.4
M12	307	238	88	71	315	10.1
M14	385	285	93	86	400	18.2
M15	456	346	102	105	500	26.2
M16	530	387	124	130	600	36.8
M25	597	412	160	182	600	60.8

*) See K and $\phi B1$ dimension from tables on page 6.

HOW TO ORDER

1.	2.	3.	4.	5.	6.	7.	8.	9.	10.	11.
XA	06	D	W	GA	J2	SP	T	X	B	T

1. sign	VALVE SERIES & STYLE & FACE-TO-FACE
XT	Full bore, seat supported, face-to-face ASME B 16.10, Table 1, long pattern, ANSI 150 (1" according to EN 558-1 basic series 1)
XA	Full bore, seat supported, face-to-face ASME 16.10, Table 2, long pattern, ANSI 300
XB	Reduced bore, seat supported, face-to-face ASME B 16.10, Table 1, short pattern, ASME 150
XC	Reduced bore, seat supported, face-to-face ASME B 16.10, Table 2, short pattern, ASME 300

2. sign	SIZE	
	Full bore	Reduced bore
01	1"	-
1H	1 1/2"	-
02	2"	-
03	3"	3"
04	4"	4"
06	6"	6"
08	8"	8"

3. sign	PRESSURE CLASS
C	ASME Class 150
D	ASME Class 300

4. sign	END CONNECTION STYLE
W	Raised face, ASME B 16.5, (Ra 3.2 - 6.3 / RMS 125 - 250), standard

5. sign	CONSTRUCTION & APPLICATION
GA	Standard construction. Live loaded packing.

6. sign	BODY MATERIAL
J2	ASTM A216 gr WCB
S6	ASTM A351 gr CF8M

7. sign	BALL / COATING & STEM MATERIAL
SP	316SS & XM-19

8. sign	SEAT TYPE
T	Soft

9. sign	SEAT MATERIAL
X	Xtreme®

10. sign	GASKET, PACKING & BEARING MATERIAL		
	Body gasket	Packing	Thrust bearing
A	PTFE	PTFE V-rings	Filled PTFE
B	Graphite	Graphite	Filled PTFE
C	PTFE	PTFE V-rings	Cobalt based alloy
D	Graphite	Graphite	Cobalt based alloy

11. sign	BOLTING MATERIALS			
	Pressure retaining		Packing gland bolting	
	Studs	Nuts	Studs	Nuts
For low emission gland packing design ISO 15848				
E*	B8M	8M	gr. 660	gr. 660
T**	L7M	2HM	B7	2H
For general service gland packing				
D*	B8M	8M	B8M	8M
F**	L7M	2HM	L7M	2HM

* Bolting materials for stainless steel body

** Bolting materials for carbon and low alloy steel body

NOTE: Other options available on application, consult factory

Subject to change without prior notice.

Metso Flow Control Inc.

Europe, Vanha Porvoontie 229, P.O. Box 304, FI-01301 VANTAA, Finland.
Tel. +358 20 483 150. Fax +358 20 483 151

North America, 44 Bowditch Drive, P.O. Box 8044, Shrewsbury, MA 01545, USA.
Tel. +1 508 852 0200. Fax +1 508 852 8172

South America, Av. Independência, 2500- Iporanga, 18087-101, Sorocaba-São Paulo, Brazil.
Tel. +55 15 2102 9700. Fax +55 15 2102 9748/49

Asia Pacific, Haw Par Centre #06-01, 180 Clemenceau Avenue, Singapore 239922.
Tel. +65 6511 1011. Fax +65 6250 0830

China, 11/F, China Youth Plaza, No.19 North Rd of East 3rd Ring Rd, Chaoyang District, Beijing 100020, China. Tel. +86 10 6566 6600. Fax +86 10 6566 2583.

Middle East, Roundabout 8, Unit AB-07, P.O. Box 17175, Jebel Ali Freezone, Dubai, United Arab Emirates. Tel. +971 4 883 6974. Fax +971 4 883 6836

www.metso.com/valves

