

3" – 24" (DN 80 – 600) SERIES 860 ANSI CLASS 600 WAFER-SPHERE® HIGH PERFORMANCE BUTTERFLY VALVES

Series 860 ANSI Class 600 high-performance *Wafer-Sphere* butterfly valves provide tight shutoff, excellent flow characteristics, and long service life. They are available in 3" – 24" (DN 80 – 600) sizes in wafer-style body design (860W) and in single-flange lugged design (860L).

The series 860 *Wafer-Sphere* butterfly valve is available in a variety of materials in standard, Fire-Tite®, NACE MR0103 construction and valves conforming to the European Pressure Equipment Directive (PED) 97/23/EC or PED requirements. Optionally available are valves specifically prepared for chlorine, oxygen, high-vacuum, and abrasive service.

FEATURES

Xtreme®

- New *Xtreme* seat provides longer life, expanded performance boundaries and greater value.

Field-Proven Single-Piece Flexible PTFE Seat Design

- No additional o-rings or metal parts required to maintain tightness.
- Lip-seal design compensates for temperature and pressure changes.
- Longer service life with less maintenance.
- Tight shut-off in either direction.

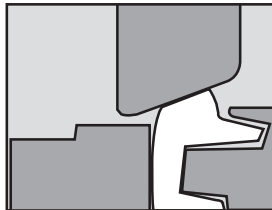

Offset Shaft and Eccentric Disc

- No seat/disc contact in the open or intermediate position.
- Eliminates wear points at top and bottom of seats.
- Lowers torque requirements.

Easy Seat Maintenance

- Simply remove body insert and replace seat; disassembly of disc and shaft is not required.



Excellent For Both On-off And Control Applications

- Superior control characteristics.
- Inherent flow characteristic is modified equal percentage.
- Wide rangeability.
- Tight shut-off even in control applications.
- Standard lugged style valves are suitable for bi-directional dead-end service at the full pressure-temperature rating of the valve.

Fire-tested Version Available

- *Fire-Tite Wafer-Sphere* valves have been tested to API 607 and ISO-10497.

Single Source Responsibility

- Purchase valves, actuators, and accessories, completely mounted, from one source.
- Available with electric, manual gear, and pneumatic double-acting or spring-return actuators and a variety of accessories including limit switches, solenoids, and positioners.

Additional Information

Please refer to the bulletins listed below for additional information on other Jamesbury® high-performance butterfly valves.

Wafer-Sphere Polymer (soft)-Seat HP Butterfly Valves

Cryogenic Service	W130-1
Steam Service	W150-1
Chlorine Service	W150-2
Oxygen Service	W150-3
Vacuum Service	W150-4
Jacketed Valves	W151-3

SPECIFICATIONS

Seat Ratings

Seat ratings are based on differential pressure with the disc in the fully closed position and refer to seats only. Maximum body working pressures and test pressure of different materials are shown in the **Valve Body Ratings** table below.

These ratings are a conservative guide for general service. Previous experience in a process or new developments and alternate seat materials may permit applications at ratings above those shown. Please consult customer service at www.metso.com/valves for specific recommendations.

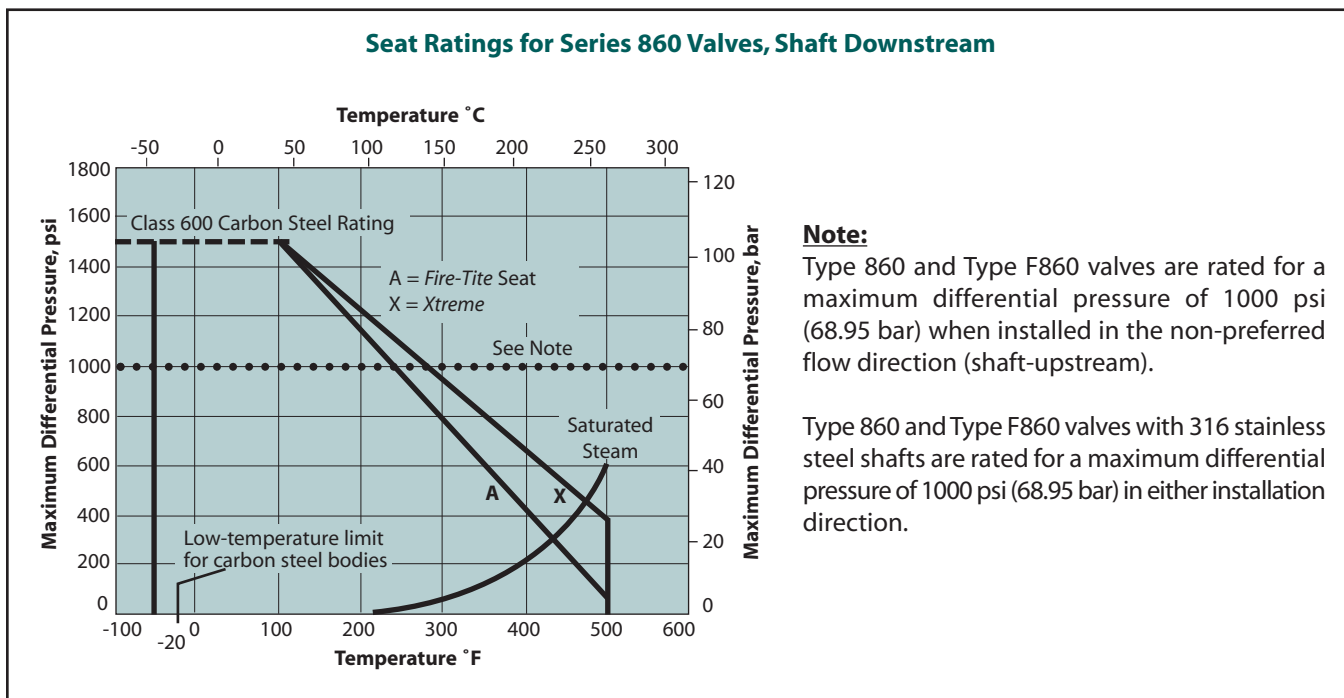

Note:
Type 860 and Type F860 valves are rated for a maximum differential pressure of 1000 psi (68.95 bar) when installed in the non-preferred flow direction (shaft-upstream).

Type 860 and Type F860 valves with 316 stainless steel shafts are rated for a maximum differential pressure of 1000 psi (68.95 bar) in either installation direction.

Flow Data

The table below provides flow coefficients for Type 860W and 860L valves covered in this bulletin. The Cv values represent the flow of water at +60°F through the valve in U.S. gallons per minute at a pressure drop of 1 psi.

The metric equivalent, Kv, is the flow of water at 16°C through the valve in cubic meters per hour at pressure drop of 1 kg/cm². To convert Cv to Kv, multiply by 0.8569.

Valve Size		Cv*
inches	DN	
3	80	155
4	100	260
6	150	750
8	200	1350
10	250	2100
12	300	2900
14	350	4000
16	400	5100
18	450	5500
20	500	7950
24	600	11300

Valve Body Ratings

These are maximum working pressure ratings of the **Valve Body Only**. The seat ratings above determine the practical pressure limitations according to actual service conditions. Test pressures below are for a hydrostatic test with the valve open.

Valve Body Pressure/Temperature Rating		
Temperature °F	Carbon Steel* psi	316 Stainless Steel* psi
-20 to 100	1480	1440
200	1360	1240
300	1310	1120
400	1265	1025
500	1205	955
Test Pressure	2250	2200

Temperature °C	Carbon Steel* bar	316 Stainless Steel* bar
-29 to 38	102.1	99.3
100	93.2	84.4
150	90.2	77.0
200	87.6	71.3
250	83.9	66.8
Test Pressure	154	150

*In accordance with ASME B16.34

Valve Torque Data

The torque required to open or close Series 860 and F860 valves can easily be calculated using the equation below. However, for your convenience, the tables on page 4 can be used as a quick guide for actuator selection. If the valve's torque is not listed in the tables, (use the equation to calculate the torque). Refer to *Jamesbury* bulletins for pneumatic and electric actuators. Select an actuator that provides the same or greater torque output than the

valve's torque. If in doubt, select the next larger actuator. Refer to these bulletins for pneumatic and electric actuator torque output values and actuator selection tables.

Manual Gear Actuators	A100-1
Spring-Diaphragm Actuators	A110-4
VPVL Mod D Actuators	A111-5
Piston Actuators (BC/BJ Series)	6B20

Torque Equation

Use the following equation (and the factors extracted from the table below) to calculate the torque required to open or close Series 860 valves.

Torque required (FT•LBS) = {(Kt) x (shut-off differential pressure in psi)} + Ts

Example:

6" (DN 150) 860W-11-36HBXZ at 900 psi (62.055 bar), installed shaft downstream. (From table, Kt = 0.195, Ts = 80.)

$$= \{0.195 \times 900\} + 80$$

$$= 256 \text{ FT}\cdot\text{LBS (To convert to N}\cdot\text{m, multiply by 1.356)}$$

Torque Equation Factors						
Valve Size		Series 860, X Seats			Series F860, Fire-Tite Seats	
		Kt Shaft Upstream	Kt Shaft Downstream	Ts	Kt, Shaft Upstream or Downstream	Ts
Inches	DN					
3	80	0.023	0.018	30	0.02	60
4	100	0.128	0.11	51	0.105	100
6	150	0.265	0.195	80	0.3	180
8	200	0.426	0.406	110	0.57	320
10	250	0.711	0.701	200	0.97	450
12	300	1.47	1.08	330	1.8	700
14	350	1.86	1.48	430	2.4	930
16	400	2.42	1.74	580	3.43	1060
18	450	2.96	2.3	710	6.11	1350
20	500	3.52	3.2	840	8.5	1790
24	600	5.16	4.45	1240	12.67	2550

- NOTES:**
- Type 860 and Type F860 valves are rated for a maximum differential pressure of 1000psi (68.95 bar) when installed in the non-preferred flow direction (shaft-upstream).
 - Type 860 and Type F860 valves with 316 stainless steel shafts are rated for a maximum differential pressure of 1000 psi (68.95 bar).

Valve Torque Data Xtreme Seat

Valve Size		Torque for Series 860W and 860L with X Seat and Shaft Downstream at Specified Shutoff Differential Pressure											
inches	DN	FT•LBS @ 600 psi	N•m @ 41.4 bar	FT•LBS @ 800 psi	N•m @ 55.2 bar	FT•LBS @ 1000psi	N•m @ 69.0 bar	FT•LBS @ 1200 psi*	N•m @ 82.8 bar*	FT•LBS @ 1400 psi*	N•m @ 96.6 bar*	FT•LBS @ 1480 psi*	N•m @ 102 bar*
3	80	40	55	45	60	48	65	52	70	55	75	57	77
4	100	115	155	140	190	160	215	185	250	205	280	215	290
6	150	200	270	235	320	275	375	315	430	355	480	370	500
8	200	350	475	435	590	515	700	600	815	680	920	710	965
10	250	620	840	760	1030	900	1220	1040	1410	1180	1600	1240	1685
12	300	980	1330	1190	1615	1410	1915	1625	2210	1840	2500	1930	2620
14	350	1320	1790	1610	2185	1910	2595	2200	2990	2500	3015	2620	3560
16	400	1625	2210	1970	2675	2320	3150	2670	3625	3400	4090	3155	4285
18	450	2090	2840	2550	3460	3010	4090	3470	4710	3930	5340	4115	5590
20	500	2760	3750	3400	4620	4040	5485	4680	6355	5320	7225	5575	7570
24	600	3910	5310	4800	6520	5690	7730	6580	8935	7470	10145	7825	10625

Xtreme Seat

Valve Size		Torque for Series 860W and 860L with X Seat, Shaft Upstream at Specified Shutoff Differential Pressure					
inches	DN	FT•LBS @ 600 psi	N•m @ 41.4 bar	FT•LBS @ 800 psi	N•m @ 55.2 bar	FT•LBS @ 1000 psi	N•m @ 69 bar
3	80	44	60	48	65	53	72
4	100	130	180	155	210	180	245
6	150	240	325	290	395	345	470
8	200	365	500	450	610	535	730
10	250	630	855	770	1045	910	1235
12	300	1210	1645	1505	2045	1800	2445
14	350	1545	2100	1920	2610	2290	3110
16	400	2030	2757	2515	3415	3000	4075
18	450	2485	3375	3080	4185	3670	4985
20	500	2950	4000	3655	4965	4360	5920
24	600	4335	5890	5370	7290	6400	8690

Torque for Series F860W and F860L with Fire-Tite Seat and Shaft Upstream or Downstream (See *)														
FT•LBS (N•m) at Specified Shutoff Differential Pressure														
Valve Size	FT•LBS @	N•m @	FT•LBS @	N•m @	FT•LBS @	N•m @	FT•LBS @	N•m @	FT•LBS @	N•m @	FT•LBS @	N•m @	FT•LBS @	N•m @
inches	DN	600 psi	41.4 bar	800 psi	55.2 bar	1000psi	69 bar	1200 psi*	82.8 bar	1400 psi*	96.6 bar	1480 psi*	101.2 bar	
3	80	72	98	76	103	80	108	84	114	88	119	90	122	
4	100	165	225	185	250	205	280	225	305	250	340	255	345	
6	150	360	490	420	570	480	650	540	735	600	815	625	850	
8	200	660	895	775	1050	890	1210	1005	1365	1120	1520	1165	1580	
10	250	1030	1400	1225	1665	1420	1930	1615	2195	1810	2460	1885	2560	
12	300	1780	2420	2140	2905	2500	3395	2860	3885	3220	4375	3365	4570	
14	350	2370	3220	2850	3870	3330	4520	3810	5175	4290	5825	4480	6085	
16	400	3120	4240	3805	5170	4490	6100	5175	7030	5860	7960	6135	8330	
18	450	5015	6810	6240	8475	7460	10130	8680	11790	9905	13450	10395	14115	
20	500	6890	9360	8590	11665	10290	13975	11990	16280	13690	18590	14370	19515	
24	600	10150	13785	12685	17225	15220	20670	17755	24110	20290	27555	21300	28925	

Notes: * Type 860 and Type F860 valves are rated for a maximum differential pressure of 1000 psi (68.95 bar) when installed in the non-preferred flow direction (shaft-upstream).

* Type 860 and Type F860 valves with 316 stainless steel shafts are rated for a maximum differential pressure of 1000 psi (68.95 bar).

PARTS AND BILLS OF MATERIALS

Part No.	Part Name	Body Material		
		Type 860_22HB, F860_22HB Type 868_22HB, F868_22HB	Type 860_36HB, F860_36HB Type 868_36HB, F868_36HB	Type 860_3600, F860_3600 Type 868_3600, F868_3600
1	Body	Carbon steel ASTM A216 Type WCB or ASTM A515 Gr. 70	316 Stainless steel ASTM A351-Type CF8M	
2	Insert	Carbon steel	316 Stainless steel	
3	Disc	316 Stainless steel ASTM A351 Type CF8M		
4	Shaft	17-4 PH Stainless steel		316 Stainless steel
5	Seat	Xtreme or PTFE/316 Stainless steel (<i>Fire-Tite</i>)		
6	Shaft Bearing	PTFE-composite backed with 316 stainless steel, Nitrided 316 SS (<i>Fire-Tite</i>)		
7	Spacer	316 Stainless steel		
8	Shaft Seal	Carbon-filled enhanced PTFE or graphite (<i>Fire-Tite</i>)		
9	Compression Ring	Stainless steel		
10	Compression Plate	Carbon steel	Stainless steel	
11	Pressure Plug 3" – 12" (DN 80 – 300) valves only	Carbon steel	Stainless steel	
12	Insert Pin	Stainless steel		
13	Disc Pin	17-4PH stainless steel		Stainless steel
14	Stud	Carbon steel, zinc plated	Stainless steel	
15	Nut	Carbon steel, zinc plated	Stainless steel	
16	Lockwasher	Carbon steel, zinc plated	Stainless steel	
17	Identification Plate	Stainless steel		
18	Drive Screw	Stainless steel		
21	Cap Screw	Stainless steel		
26	Indicator Plate	Stainless steel		
27	Drive Screw	Stainless steel		
29	Indicator Pointer	Carbon steel		
40	Body Seal 3" – 4" (DN 80 – 100) 860, 3" – 12" (DN 80 – 300) F860	PTFE or graphite (<i>Fire-Tite</i>)		
42	Plug Seal 3" – 12" (DN 80 – 300) 860, valves only	PTFE or graphite (<i>Fire-Tite</i>)		
47	Retaining Ring 3" – 6" (DN 80 – 150) valves only	Inconel® *		
53	Cover Plate 14" – 24" (DN 350 – 600) only	Carbon steel	Stainless steel	
54	Gasket 14" – 24" (DN 350 – 600) only	PTFE or graphite (<i>Fire-Tite</i>)		
55	Cap Screw 14" – 24" (DN 350 – 600) only	Carbon steel	Stainless steel	
56	Lockwasher 14" – 24" (DN 350 – 600) only	Carbon steel	Stainless steel	
64	Thrust Bearing	316 Stainless steel		
72	Base Plate 8" (DN 200) only	Carbon steel		
73	Cap Screw 8" (DN 200) only	Carbon steel, zinc plated		
74	Lockwasher 8" (DN 200) only	Carbon steel, zinc plated		
75	Blow-out Spacer 3" – 6" (DN 80 – 150) valves only	Stainless steel		

DIMENSIONS

3" - 12" (DN 80 - 300) Series 860W and 860L

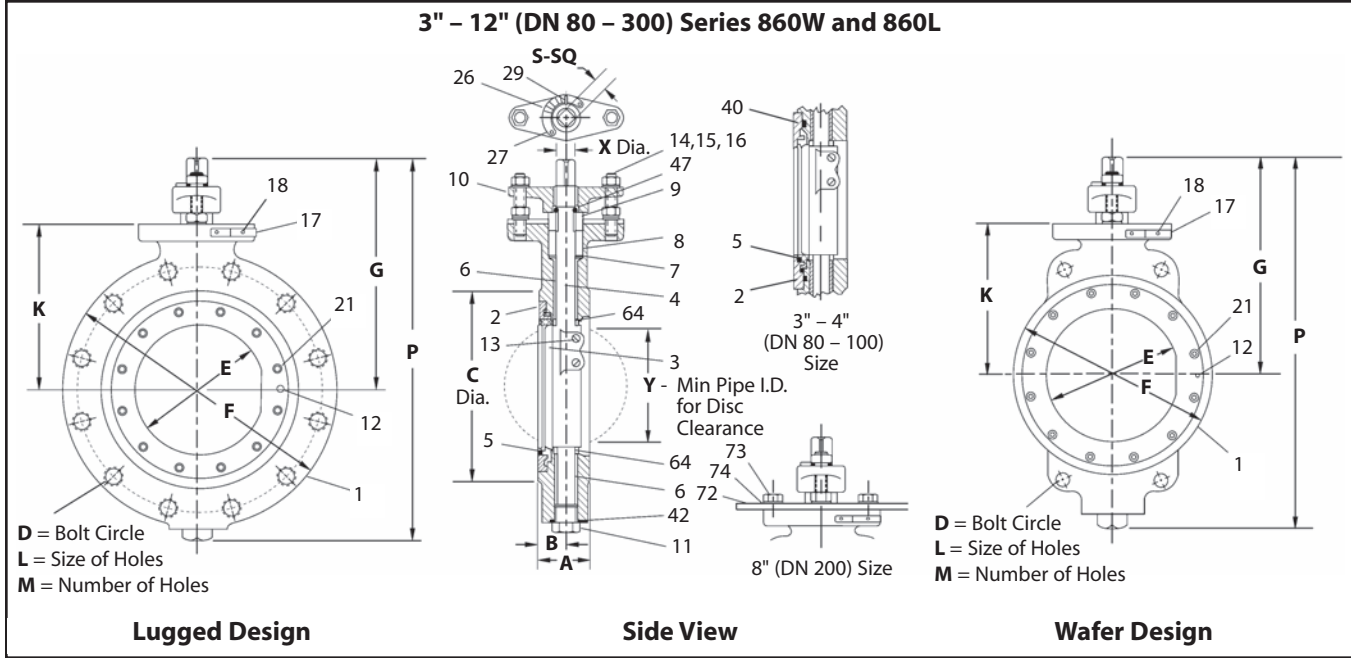

3" - 12" (DN 80 - 300) Type 860W Wafer-Sphere Valves ANSI Class 600 Wafer Design

Valve Size inches	Approximate Dimensions - inches														Approx. Weight lb.
	A	B	C	D	E	F	G	K	L	M	P	S	X	Y	
3	2.37	1.25	5.00	6.62	2.94	5.50	7.87	5.12	0.87	4	13.12	0.50	0.62	2.75	26
4	2.87	1.44	6.19	8.50	3.94	7.25	9.75	6.12	1.00	4	16.62	0.62	0.87	3.56	46
6	3.00	1.62	8.50	11.50	5.50	8.50	11.38	8.12	1.13	4	20.19	0.87	1.12	5.50	70
8	4.00	2.00	10.62	13.75	7.81	10.62	13.25	9.50	1.25	4	23.94	1.13	1.50	7.19	118
10	4.75	2.37	12.75	17.00	9.34	12.75	15.31	11.31	1-1/4 - 8	4	28.37	1.31	1.75	8.94	243
12	5.75	2.87	15.00	19.25	11.00	15.00	17.56	13.56	1-1/4 - 8	4	33.50	1.62	2.13	10.62	359

Valve Size DN	Approximate Dimensions - mm														Approx. Weight kg
	A	B	C	D	E	F	G	K	L	M	P	S	X	Y	
80	60	32	127	168	75	140	200	130	0.87	4	333	13	16	70	12
100	73	37	157	216	100	184	248	155	1.00	4	422	16	22	90	21
150	76	41	216	292	140	216	289	206	1.12	4	513	22	28	140	32
200	102	51	270	349	198	270	337	241	1.25	4	608	28	38	183	54
250	121	60	324	432	237	324	389	287	1-1/4 - 8	4	721	33	44	227	110
300	146	73	381	489	279	381	446	344	1-1/4 - 8	4	851	41	57	270	163

3" - 12" (DN 80 - 300) Type 860L Wafer-Sphere Valves ANSI Class 600 Single-Flange Lugged Design

Valve Size inches	Approximate Dimensions - inches														Approx. Weight lb.
	A	B	C	D	E	F	G	K	L	M	P	S	X	Y	
3	2.37	1.25	5.00	6.62	2.94	8.25	7.87	5.12	3/4 - 10	8	13.12	0.50	0.62	2.75	33
4	2.87	1.44	6.19	8.50	3.94	10.75	9.75	6.50	7/8 - 9	8	16.62	0.62	0.87	3.56	63
6	3.00	1.62	8.50	11.50	5.50	14.00	11.37	8.12	1 - 8	12	20.19	0.87	1.12	5.50	112
8	4.00	2.00	10.62	13.75	7.41	16.50	13.25	9.50	1-1/8 - 8	12	23.94	1.12	1.50	7.19	198
10	4.75	2.37	12.75	17.00	9.34	20.00	15.31	11.31	1-1/4 - 8	16	28.37	1.31	1.75	8.94	368
12	5.75	2.87	15.00	19.25	11.00	22.00	17.56	13.56	1-1/4 - 8	20	33.50	1.62	2.25	10.62	510

Valve Size DN	Approximate Dimensions - mm														Approx. Weight kg
	A	B	C	D	E	F	G	K	L	M	P	S	X	Y	
80	60	32	127	168	75	210	200	130	3/4 - 10	8	333	13	16	70	15
100	73	37	157	216	100	273	248	155	7/8 - 9	8	422	16	22	90	29
150	76	41	216	292	140	356	289	206	1 - 8	12	513	22	28	140	51
200	102	51	270	349	198	419	337	241	1-1/8 - 8	12	608	28	38	183	90
250	121	60	324	432	237	508	389	287	1-1/4 - 8	16	721	33	44	227	167
300	146	73	381	489	279	559	446	344	1-1/4 - 8	20	851	41	57	270	231

DIMENSIONS

14" – 24" (DN 350 – 600) Series 860W and 860L

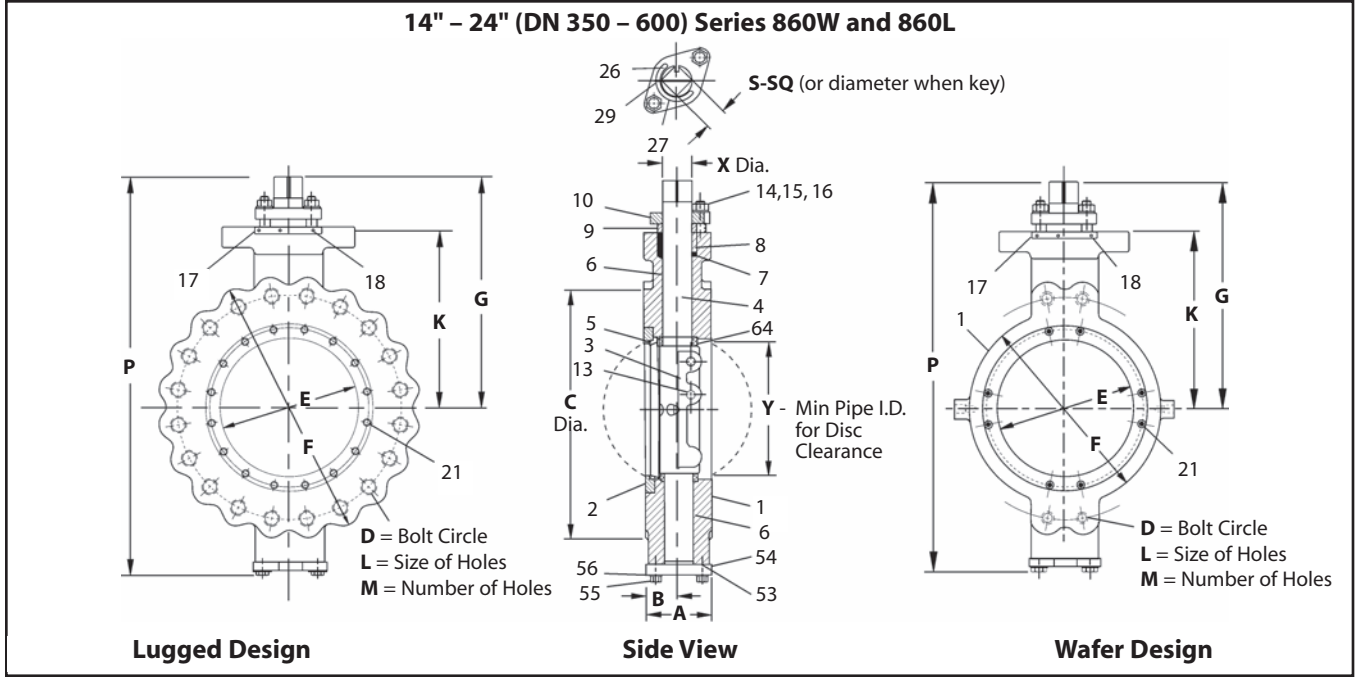

14" – 24" (DN 350 – 600) Type 860W Wafer-Sphere Valves ANSI Class 600 Wafer Design

Valve Size inches	Approximate Dimensions – inches														Approx. Weight lb.
	A	B	C	D	E	F	G	K	L	M	P	S	X	Y	
14	6.25	3.12	16.25	20.75	12.3	17.75	21.00	16.37	1-3/8 - 8	4	37.00	2.00	2.75	11.00	440
16	6.75	3.37	18.50	23.75	14.25	18.69	20.44	15.44	1-1/2 - 8	4	36.00	2.00	3.00	12.25	630
18	7.75	3.87	21.00	25.75	16.25	21.00	28.12	19.62	1-5/8 - 8	4	48.12	3.50*	3.50	14.75	820
20	8.25	4.12	23.19	28.50	17.87	23.19	27.25	22.25	1-5/8 - 8	4	49.25	3.50*	4.00	16.37	1070
24	11.00	4.62	27.25	33.00	21.00	29.62	35.00	24.50	1-7/8 - 8	4	61.37	4.00*	5.00	19.37	1660

Valve Size DN	Approximate Dimensions – mm														Approx. Weight kg
	A	B	C	D	E	F	G	K	L	M	P	S	X	Y	
350	159	79	413	527	313	451	533	416	1-3/8 - 8	4	940	51	70	279	200
400	171	86	470	603	362	475	519	392	1-1/2 - 8	4	914	51	76	311	286
450	197	98	533	654	413	533	714	498	1-5/8 - 8	4	1222	89*	89	375	372
500	210	105	589	724	454	589	692	565	1-5/8 - 8	4	1251	89*	102	416	485
600	280	117	692	838	533	752	889	622	1-7/8 - 8	4	1559	89*	114	492	753

* Diameter with 7/8" key

14" – 24" (DN 350 – 600) Type 860L Wafer-Sphere Valves ANSI Class 600 Single-Flange Lugged Design

Valve Size inches	Approximate Dimensions – inches														Approx. Weight lb.
	A	B	C	D	E	F	G	K	L	M	P	S	X	Y	
14	6.25	3.12	16.25	20.75	12.31	23.75	21.00	16.37	1-3/8 - 8	20	37.00	2.00	2.75	11.00	630
16	6.75	3.37	18.50	23.75	14.25	27.00	20.44	15.44	1-1/2 - 8	20	36.00	2.00	3.00	12.25	840
18	7.75	3.87	21.00	25.75	16.25	29.25	28.12	19.62	1-5/8 - 8	20	48.12	3.50*	3.50	14.75	1110
20	8.25	4.12	23.19	28.50	17.87	32.00	27.25	22.25	1-5/8 - 8	20	49.25	3.50*	4.00	16.37	1410
24	11.00	4.62	27.25	33.00	21.00	37.00	35.00	24.50	1-7/8 - 8	20	61.37	4.00*	5.00	19.37	2100

Valve Size DN	Approximate Dimensions – mm														Approx. Weight kg
	A	B	C	D	E	F	G	K	L	M	P	S	X	Y	
350	159	79	413	527	313	603	533	416	1-3/8 - 8	20	940	51	70	279	286
400	171	86	470	603	362	686	519	392	1-1/2 - 8	20	940	914	96	311	381
450	197	98	533	654	413	743	714	498	1-5/8 - 8	20	1222	89*	89	375	503
500	210	105	589	724	454	813	692	565	1-5/8 - 8	20	1251	89*	102	416	640
600	280	117	692	838	533	940	889	622	1-7/8 - 8	20	1559	89*	114	492	953

* Diameter with 7/8" key

HOW TO ORDER SERIES 860 WAFER-SPHERE VALVES

These *Wafer-Sphere* valves are described by size and a multi-character code that defines body configuration, body, disc, shaft, seat and seal materials. Explanation of the code for valves in this bulletin is as follows:

1	2	3	4	5	6	7	8
6	860	L	-	11	22	HB	XZ

EXAMPLE: The above example is for a 6" ANSI Class 600 single-flange lugged-design valve with carbon steel body, 316 stainless steel disc, 17-4PH stainless steel shaft, *Xtreme* seat, and carbon-filled enhanced PTFE shaft seal.

1	Size*										
inches	3	4	6	8	10	12	14	16	18	20	24
DN	80	100	150	200	250	300	350	400	450	500	600

* When ordering, state size code in inches. Consult factory for larger sizes

2	Pressure Class
860	Standard ANSI Class 600
868	Standard ANSI Class 600 w/CE Marking and Documentation
F860	<i>Fire-Tite</i> ANSI Class 600
F868	<i>Fire-Tite</i> ANSI Class 600 w/CE Marking and Documentation

3	Body Styles
W	Wafer
L	Single Flange Lugged

4	Special Service
O	Oxygen
—	No entry if standard

5	Type
11	Standard (Non <i>Fire-Tite</i>)
31	<i>Fire-Tite</i>

6	Body Material
22	Carbon Steel
36	316 Stainless Steel

7	Trim Material
HB	316 Stainless disc, 17-4 PH stainless shaft (NACE compatible)
00	(not NACE compatible) Same as body material
36	(not NACE compatible) 316 Stainless steel** (not NACE compatible)

** For use with carbon-steel body code. For 316 stainless body with 316 trim, use "00".

8	Seat & Seal Material	
	Seat	Seal
Standard		
XZ	<i>Xtreme</i>	Carbon-Filled Enhanced PTFE
Fire-Tite		
AE	PTFE / Stainless Steel	Graphite

9	Modifier Code
—	Standard
For others, please describe. Factory will supply code.	

Subject to change without prior notice.

Metso Flow Control Inc.

Europe, Vanha Porvoontie 229, P.O. Box 304, FI-01301 Vantaa, Finland.
Tel. +358 20 483 150. Fax +358 20 483 151

North America, 44 Bowditch Drive, P.O. Box 8044, Shrewsbury, MA 01545, USA.
Tel. +1 508 852 0200. Fax +1 508 852 8172

South America, Av. Independência, 2500- Iporanga, 18087-101, Sorocaba-São Paulo Brazil.
Tel. +55 15 2102 9700. Fax +55 15 2102 9748/49

Asia Pacific, Haw Par Centre #06-01, 180 Clemenceau Avenue, Singapore 239922.
Tel. +65 6511 1011. Fax +65 6250 0830

China, 11/F, China Youth Plaza, No.19 North Rd of East 3rd Ring Rd, Chaoyang District, Beijing 100020, China. Tel. +86 10 6566 6600. Fax +86 10 6566 2583.

Middle East, Roundabout 8, Unit AB-07, P.O. Box 17175, Jebel Ali Freezone, Dubai, United Arab Emirates. Tel. +971 4 883 6974. Fax +971 4 883 6836

www.metso.com/valves

