

INSTALLATION MANUAL FOR DODGE PLUG IN MODEL 250 POWER SUPPLY

These instructions must be read thoroughly before installing or operating this product.

WARNING: Only qualified electrical personnel familiar with the construction and operation of this equipment and the hazards involved should install, adjust, and/or service this equipment. Failure to observe this precaution can result in bodily injury.

WARNING: The user is responsible for conforming to the National Electrical Code and all other applicable local codes in respect to wiring practices, grounding, disconnects, and overcurrent protection. Installation of an approved disconnecting means in the line side of the controller is of particular importance. Failure to observe these precautions could result in severe bodily injury or loss of life.

WARNING: Subsequent steps require rotating parts and/or electrical circuits to be exposed. Stay clear if unit must be running or disconnect and lockout or tag power source if contact must be made. Failure to observe these precautions could result in severe bodily injury or loss of life.



WARNING: Because of the possible danger to persons(s) or property from accidents which may result from the improper use of products, it is important that correct procedures be followed. Products must be used in accordance with the engineering information specified in the catalog. Proper installation, maintenance and operation procedures must be observed. The instructions in the instruction manuals must be followed. Inspections should be made as necessary to assure safe operation under prevailing conditions. Proper guards and other suitable safety devices or procedures as may be desirable or as may be specified in safety codes should be provided, and are neither provided by Baldor Electric Company nor are the responsibility of Baldor Electric Company. This unit and its associated equipment must be installed, adjusted and maintained by qualified personnel who are familiar with the construction and operation of all equipment in the system and the potential hazards involved. When risk to persons or property may be involved, a failsafe device must be an integral part of the driven equipment beyond the speed reducer output shaft.

Specifications:

Input voltage: 115 VAC 50-60 Hz
Output voltage: 15-100 VDC Nominal
Output current: 0.5 Amp Maximum
Output wattage: 50 Watts Maximum
Dimensions: 2.88" H, 2.38" W, 1.75" D

Description:

Model 250 is an octal-base power supply that converts 115 VAC, 50-60 Hz to a DC voltage. It provides one fixed 100 VDC output and one adjustable (15 to 100 VDC) output. The Model 250 is capable of providing DC operating voltage to 1 or 2 clutches or brakes (each with 50 watts or less power consumption). If two units are operated with the Model 250 power supply, only one unit should be energized at a time.

Note: Switches Furnished By User.

Installation and Operating Instructions:

1. Be sure power is locked off when wiring a power supply installation.
2. Use adequate sized wire. No. 18 gauge is recommended for runs less than 25 feet. No. 16 gauge is recommended for runs 25 feet or longer.
3. The neutral or grounded side of the 115 VAC line must be connected to terminal 5 on the octal socket. A voltmeter connected between the neutral line and line ground will read 0 volts. The hot side of the 115 VAC line must be connected to terminal 1.

Note 1: Connect switches per diagrams. Do not connect switch for the clutch or brake in coil circuit.

Note 2: Output voltage under load of the power supply is approximately 100 VDC with 115 VAC input. This is suitable for clutches and brakes rated 90 VDC.

Note 3: Output voltage without load is about 160 VDC.

Model 250 used with 2 units - adjustable voltage on unit #1, fixed 100 VDC on unit #2. Connection Instructions (See Figure 1):

1. All connections are made to terminals on octal socket.
2. Connect unit #1 to terminals 6 and 8.
3. Connect unit #2 to terminals 3 and 6.
4. Connect side Sa of a double-pole, double-throw (DPDT) switch to terminals 3, 7, and 8; the switch common must be connected to terminal 7.
5. Connect side Sb of the switch to terminals 6 and 2; the switch common must be connected to terminal 6.
6. Connect 115 VAC, 50-60 Hz to terminals 1 and 5.

NOTE: The neutral or grounded side must be connected to terminal 5.



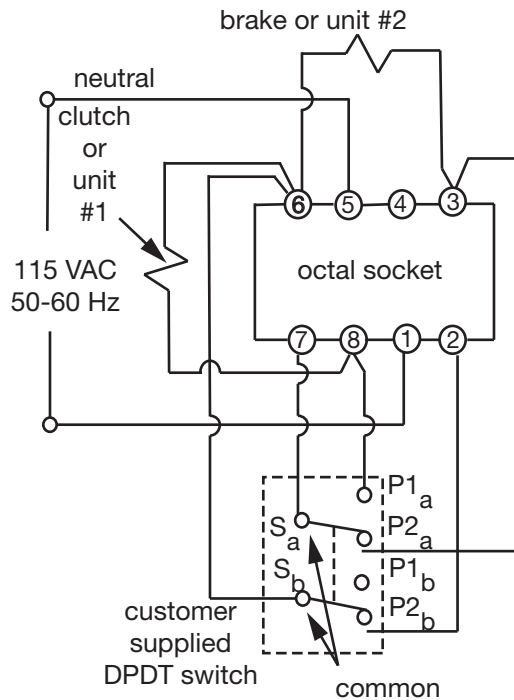

**Figure 1 - Wiring 2 Units
(adjustable voltage on unit #1)**

Operation:

1. Plug power supply into octal socket.
2. Turn on power source.
3. Voltage adjustments are made by removing plug button on top of power supply case. This will expose a slotted screwdriver adjustment. Turn the adjustment screw clockwise to increase voltage, or counterclockwise to decrease voltage. When wired as described above, the adjusted voltage will be applied across unit #1.
4. With switch in position P1, unit #1 is energized with adjusted voltage and unit #2 is de-energized.
5. With switch in position P2 (normally closed), unit #2 is energized with 100 VDC and unit #1 is deenergized.
6. If unit fails to operate, refer to the Troubleshooting section.

Note: If unit #1 is energized with fixed 100 VDC, and unit #2 with adjustable DC voltage, remove lead between terminal 2 of octal socket and P2b of switch. Add lead between terminal 2 of octal socket and P1b of switch.

Model 250 used with 2 units – adjustable voltage on both units. Connection Instructions (See Figure 2):

1. All connections are made to terminals on octal socket.
2. Connect unit #1 to terminals 6 and 8.
3. Connect unit #2 to terminals 3 and 6.
4. Connect a SPDT switch to terminals 3, 7, and 8; the switch common must be connected to terminal 7.
5. A maintained-contact type SPDT switch should be used.
6. Connect 115 VAC, 50-60 Hz to terminals 1 and 5.

NOTE: The neutral or grounded side must be connected to terminal 5.

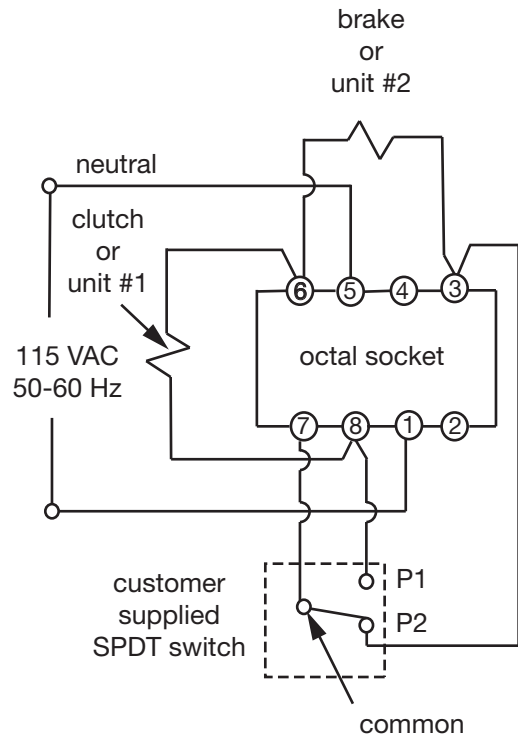

**Figure 2 - Wiring 2 Units
(adjustable voltage on both units)**

Operation:

1. Plug power supply into octal socket.
2. Turn on power source.
3. Voltage adjustments are made by removing plug button on top of power supply case. This will expose a slotted screwdriver adjustment. Turn the adjustment screw clockwise to increase voltage, or counterclockwise to decrease voltage. When wired as described above, this same adjusted voltage will be applied across both unit #1 and unit #2.
4. With switch in position P1, unit #1 is energized with adjusted voltage and unit #2 is de-energized.
5. With switch in position P2 (normally closed), unit #2 is energized with adjusted voltage and unit #1 is de-energized.
6. If unit fails to operate, refer to the Troubleshooting section.

Model 250 used with 1 unit. Connection Instructions (See Figure 3):

1. All connections are made to terminals on octal socket.
2. Connect unit (clutch or brake) to terminals 6 and 8.
3. Connect switch to terminals 7 and 8; the switch common should be connected to terminal 7. Use a maintained contact SPDT (shown in Figure 3) or SPST switch.
4. Connect 115 VAC, 50-60 Hz to terminals 1 and 5.

Warning: The neutral or grounded side must be connected to terminal 5.

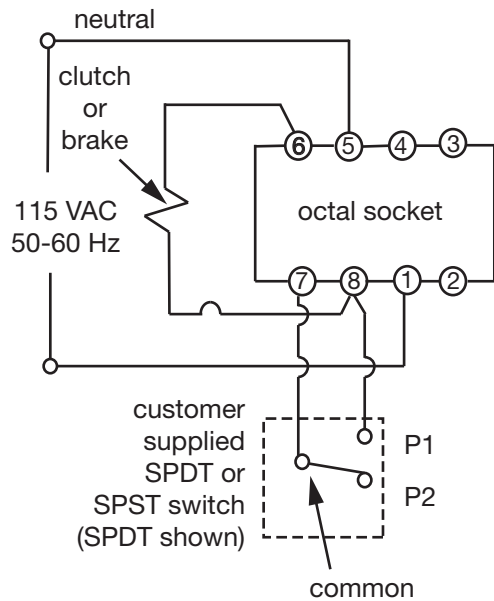

Figure 3 - Wiring for 1 Unit

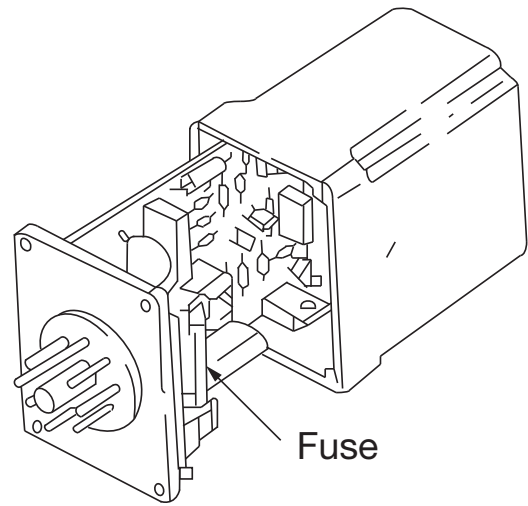

Figure 4 - Fuse Location

Operation

1. Plug power supply into octal socket.
2. Turn on power source.
3. Voltage adjustments are made by removing plug button on top of power supply case. This will expose a slotted screwdriver adjustment. Turn the adjustment screw clockwise to increase voltage, or counterclockwise to decrease voltage.
4. With switch in position P1 (or switch closed when using SPST) the clutch or brake is energized.
5. With switch in position P2 (or switch open when using SPST) the clutch or brake is de-energized.
6. If unit fails to operate, refer to the Troubleshooting section.

Maintenance

Fuse location and access

Model 250 has an internal fuse. The fuse can be checked without removing the power supply cover. First remove the power supply from the octal socket. An ohmmeter connected between pins 1 and 4 on the module will read near infinity if the fuse has burned out. If blown then replace with type 3AG 0.6 amp fuse.

NOTE: Do not use slow-blow type fuse.

To replace the fuse, remove four fasteners holding cover of base plug. Carefully remove the cover. The fuse is located as shown in Figure 4. Visually check the fuse. If the fuse is burned out, remove it, and replace with a new fuse of proper size and type. Carefully replace the cover and fasteners.

Troubleshooting

If the unit fails to operate or operates in an improper manner, use the following procedure to identify and resolve the problem.

1. Check the power source (115 VAC, 50-60 Hz line voltage). Is it turned on? Using an AC voltmeter, check the voltage between terminals 1 and 5. The voltage should be between 110 and 120 VAC.
2. Check actual wiring against the wiring diagram. Check to see if voltage adjustment is turned up high enough to operate clutch or brake.
3. Check fuse. If the fuse is burned out, replace it with one of the same type and rating. Review entire troubleshooting procedure to identify reason for blown fuse.
4. Disconnect clutch and/or brake from power supply.
5. Check resistance of clutch and/or brake coils. If coil is shorted or open it should be replaced.
6. Check the connections between the power supply and the clutch and/or brake to be operated. If the connections are loose or the wires damaged or grounded, correct the problem.
7. If the above corrective actions do not restore normal operation, the power supply should be replaced with a new one.

Accessory Requirements

The following accessories are required for installation, but are not supplied with the Model 250 power supply.

1. Octal socket - DODGE part number 032401.
2. Switch - One switch (SPST, SPDT, or DPDT depending upon applications). Switch should be contact type. A minimum of 6A, 120VAC is recommended.
3. Hook-up wire - as required.



World Headquarters

P.O. Box 2400, Fort Smith, AR 72902-2400 U.S.A., Ph: (1) 479.646.4711, Fax (1) 479.648.5792, International Fax (1) 479.648.5895

Dodge Product Support

6040 Ponders Court, Greenville, SC 29615-4617 U.S.A., Ph: (1) 864.297.4800, Fax: (1) 864.281.2433

www.baldor.com

© Baldor Electric Company
MN4008 (Replaces 499061)



All Rights Reserved. Printed in USA.
11/10 Printshop 500