



Model FT4X Gas Mass Flow Meter For Oil & Gas & Industrial Applications

- 2nd Generation DDC-Sensor™: Robust, non-cantilevered design
- Programmable Contract Time
- Gas-SelectX®: menu of field selectable gas compositions
- Gross Heating Value and Density Calculations of Gas Mix
- Standard Data Logger with date/time stamp and 40 24-Hour daily totals
- CAL-V™ Calibration Validation
- Insertion, Inline, and Remote Styles
- FC10 Flow Conditioners for use with insertion meters
- Measures gas flow rate in SCFM, MCFD, KG/H, & many more
- Wide measurement range: up to 1000:1 turndown; 100:1 typical
- Two 4-20mA outputs for flow rate or temperature
- Choice of HART or RS485 Modbus RTU communication options
- USB port to connect to a PC, standard
- Free FT4X View™ Software available
- Welded, 316 SS sensor construction, Carbon Steel flow body optional
- Microprocessor based, field-programmable electronics
- Standard on-board 2 line x 16 character, backlit display with configuration panel
- NIST traceable calibration
- Low-end sensitivity for flares, vents, and leak detection
- Negligible pressure drop
- FM (U.S.) & FMc (CANADIAN) approved for Class I, Div 1; ATEX/IECEX approved for Zone 1
- NEMA 4X and CE Mark
- Accuracy Compliant with BLM 3175 & API 14.10

FOX THERMAL
 399 RESERVATION ROAD
 MARINA, CA 93933
 PHONE: 831-384-4300
 FAX: 831-337-5786
 sales@foxthermal.com
 www.foxthermal.com

Model FT4X

Thermal Mass Flow Meter & Temperature Transmitter



Accuracy Compliant with
 BLM 3175 & API 14.10
 • Flare Gas • Sales Gas • Fuel Gas •

New Standard Data Logger with Date/Time Stamp

Every Fox Thermal Model FT4X comes equipped with an advanced intrinsic Data Logger for advanced record-keeping and data retention. Data logging is commonly used in applications such as flare and waste gas monitoring, gas studies, gas royalties and allocation, and gas flow research.

To start logging daily totals, alarms and events, the Data Logger must be activated upon installation. It can be activated quickly and easily through the flow meter's front panel keypad. The date and local time must be set for accurate records.

The Data Logger records flow rate totals and other events and alarms. The advanced features of the Model FT4X Data Logger include:

- 40 daily totals (24-hour totals)
- Settable Contract Time defines Contract Day
- Time/date stamped alarm & event logs; 7 year history
- Power off totalizer; power failure creates event log entry

The logs in the Model FT4X Data Logger also give information about the meter's settings and functionality:

- View the meter's gas or gas mix composition
- View the meter's configuration and other meter settings
- View Calibration Validation historical test data
- View and print logs of events and alarms

The Data Logger can be accessed with a RS485 MODBUS MS/TP communication option and the free FT4X View™ Software.

MODEL FT4X

Fast and Flexible Gas Flow Measurement

Offering you the flexibility to reprogram the gas composition at the push of a button, rotate the housing as needed for tight installations, and configure meter settings from advanced software, the Fox Thermal Model FT4X thermal mass flow meter and temperature transmitter can be used in a large variety of Oil & Gas, Industrial, and Wastewater gas flow measurement applications.

Theory of Operation

FOX Thermal Flow Meters use a constant temperature differential (constant ΔT) technology to measure mass flow rate of air and gases. The thermal mass flow sensor consists of two Resistance Temperature Detectors (RTD's).

The Reference RTD measures the gas temperature. The instrument electronics heat the mass flow sensor, or heated element, to a constant temperature differential (constant ΔT) above the gas temperature and measures the cooling effect of the gas flow. The electrical power required to maintain a constant temperature differential is directly proportional to the gas mass flow rate. The microprocessor linearizes this signal to deliver a linear 4-20mA signal.

Fox Thermal Model FT4X Thermal Gas Mass Flow Meter Features

The Fox Thermal Model FT4X measures gas flow rate in standard units without the need for temperature or pressure compensation. It provides two isolated 4-20mA outputs, a pulse/alarm output, a contact input, and optional RS485 Modbus RTU or HART communication options.

With a standard on-board 2-line x 16-character, backlit display, operators can view flow rate, total, elapsed time, process gas temperature, and alarms. The display/configuration panel can also be used to access flow meter settings, such as 4-20mA and pulse output scaling, pipe diameter, low flow cutoff, flow filtering (damping), display options, and high or low alarm limits.

The Model FT4X is available in both insertion and inline styles. The insertion probe is easily installed by drilling a hole in the pipe and welding on a 1" NPT coupling. A Fox Thermal-supplied compression fitting secures the probe in place. It is supplied with 316 stainless steel wetted materials standard. Inline models are available in 3/4" to 6" sizes and includes built-in flow conditioners that eliminate the need for long, straight pipe runs.

A USB port to connect to a computer or laptop is standard; interface options include 4-20mA, pulse, HART, and RS485 Modbus RTU.

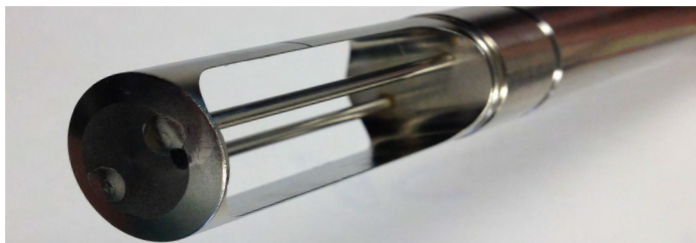

The Fox Thermal 2nd generation DDC-Sensor™ eliminates sensor element vibration which can lead to metal fatigue and failure.



The Model FT4X is available with inline flowbodies with built-in flow conditioners. The FT4X is approved for FM/FMc Class I, Division 1, ATEX/IECEX Zone 1. CE Mark. Flow measurement accuracy of the FT4X is compliant with BLM 3175 & API 14.10.

Advanced Features

Suitable for harsh and hazardous environments, the instrument features:

- Robust DDC-Sensor™ Design
- Gas-SelectX® gas selection menu featuring new Oil & Gas Menu
- Data Logger with 40 Daily Totals (24 hour totals)
- Settable Contract Time defines Contract Day
- Gross Heating Value and Density calculations of gas mix
- CAL-V™ Calibration Validation
- Rotatable probe: allows ± 180 degree swivel
- FM/FMc, ATEX, IECEx approvals. CE mark.
- 10-30VDC power input, standard
- NIST-traceable calibration
- Free FT4X View™ Software

Perfect for Oil & Gas, Industrial, and Wastewater applications, the Model FT4X is the latest instrument offered in the Fox Thermal product line.

CAL-V™

For customers that need a quick and easy way to verify the calibration of the meter in the field, the Model FT4X offers the CAL-V™ feature. This feature can be accessed and run through the meter's standard display and configuration panel, Modbus, or the FT4X View™ Software. The test takes less than 5 minutes to run and produces a pass/fail result at the conclusion of the test. A fail result may indicate either a dirty sensor or the need to recalibrate.

If the CAL-V™ test is performed using the FT4X View™ software, a Calibration Validation Certificate can be produced at the conclusion of the test. The certificate will show the date and time of the test along with meter data such as firmware version, meter serial number, configuration settings, and currently selected gas/gas mix. This in-situ calibration validation test helps operators comply with environmental mandates and eliminates the cost and inconvenience of annual factory calibration. View historical CAL-V™ test data in the log.

DDC-Sensor™

The Fox Thermal DDC-Sensor™ is the state-of-the-art sensor technology used in the Fox Thermal Model FT4X Thermal Gas Flow Meter. The DDC-Sensor™, a Direct Digitally Controlled sensor, is unlike other thermal flow sensors available on the market. Instead of using traditional analog circuitry, the DDC-Sensor™ is interfaced directly to the FT4X microprocessor for more speed and programmability. The DDC-Sensor™ accurately responds to changes in process variables (gas flow rate, pressure, and temperature) to determine mass flow rate, totalized flow, and temperature.

Fox Thermal's DDC-Sensor™ provides a technology platform for calculating accurate gas correlations. The FT4X correlation algorithms allow the meter to be calibrated on a single gas in the factory while providing the user the ability to select other gases or gas mixes in the Gas-SelectX® menu. Fox Thermal's Model FT4X with its DDC-Sensor™ and advanced correlation algorithm provides an accurate, multi-gas-capable thermal gas flow meter.

Gas-SelectX® Gas Selection Menu

Many customers need a fast solution to their monitoring needs. For these cases, Fox Thermal has developed the Gas-SelectX® gas selection menu feature for the Model FT4X flow meter. Gas-SelectX® allows the user to choose from a menu of several common gases or gas mixtures for their application.

The Gas-SelectX® feature has three gas menus with the following available gases:

Pure Gas Menu	Mixed Gas Menu	O&G Gas Menu
Air	Air	Methane (C1)
Argon	Argon	Ethane (C2)
Butane	Butane	Propane (C3)
Carbon Dioxide	Carbon Dioxide	i-Butane (C4)
Methane	Methane	n-Butane (C4)
Natural Gas*	Nitrogen	Pentanes (C5)
Nitrogen	Oxygen	Hexanes (C6)
Oxygen	Helium	Carbon Dioxide
Helium	Hydrogen	Nitrogen
Hydrogen	Propane	Heptanes (C7)
Propane	Ethane	Octanes (C8)
		Nonanes+(C9+)

*Choosing Natural Gas sets the NAESB average in a pre-programmed mix of methane, ethane, propane, nitrogen, and carbon dioxide.

The meter's proprietary algorithms allow the user to switch gases or gas mixes in the field, as needed. The Pure and Mixed Gas Menus make the FT4X ideal for measurement of flare gas and a variety of other gases.

With the O&G Menu on the Model FT4X, Gas-SelectX® contains gases common to Oil & Gas applications. Whether you need to measure natural gas, air, flare gas, vent gas, or digester gas, the FT4X brings these options and more to the user with a quick push of a button.



The Model FT4X is available with FC10 Flow Conditioners for use with insertion flow meters.

FC10 Flow Conditioners

Fox Thermal now offers flow conditioners for use with insertion meters. Customers want the shorter straight pipe run requirements that you can get from an inline style meter, but often require an insertion style flow meter for the lower cost and the easy installation in tight areas.

The FC10 flow conditioners are installed between two flanges upstream of the insertion flow meter and used to correct irregular flow profiles due to elbows or obstructions upstream from the meter's probe. Use of a flow conditioner helps ensure the highest flow meter accuracy.

FT4X View™ Software

Fox Thermal has developed advanced software - FT4X View™ - a free PC-compatible application available for download from the Fox Thermal website. Connect your laptop, PC, or control station to the meter using the USB port interface to access the meter's data and configure the meter's settings.

FT4X View™ allows:

- Quick access to all configuration parameters and available gas selections
- Selection of measurement units, flow and temperature ranges, alarm settings and more
- View or print a CAL-V™ Calibration Validation certificate
- Display of alarm codes
- Storage of meter configurations to a file that can be archived
- Raw data to be viewed in order to diagnose or troubleshoot your meter
- Data logging to an Excel™ spreadsheet
- View gross heating value and density of gas mix

DIMENSIONS

Meter Dimensional Drawings

Drawings of the Model FT4X meter and retractor dimensions are shown here in inches (mm).

Local Styles

Local Insertion Meter

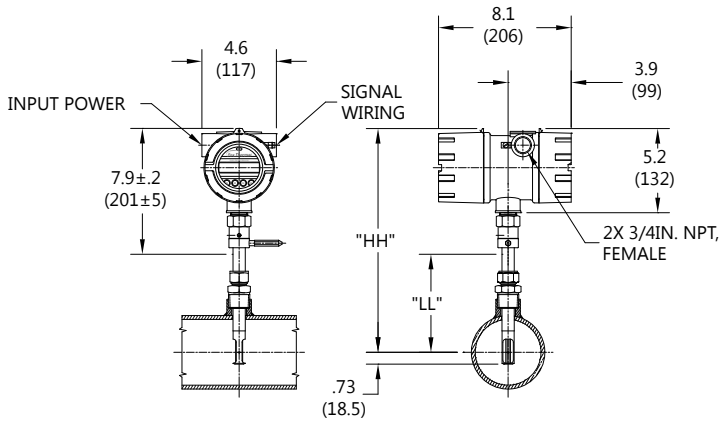

Dimensions		
Probe Length	"LL" Dim, In (mm)	"HH" Dim, In (mm)
6"	6.0 (152)	13.9 (353)
9"	9.0 (229)	16.9 (429)
12"	12.0 (305)	19.9 (505)
15"	15.0 (381)	22.9 (582)
18"	18.0 (457)	25.9 (658)
24"	24.0 (610)	31.9 (810)
30"	30.0 (762)	37.9 (963)
36"	36.0 (914)	43.9 (1115)

Local Insertion Meter with Retractor

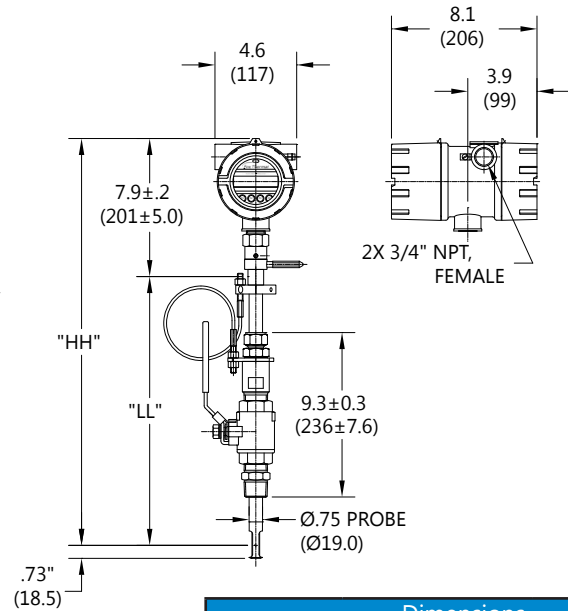

Dimensions		
Retractor	"LL" Dim, In (mm)	"HH" Dim, In (mm)
15R	15.0 (381)	22.9 (582)
18R	18.0 (457)	25.9 (658)
24R	24.0 (609)	31.9 (810)
30R	30.0 (762)	37.9 (963)
36R	36.0 (914)	43.9 (1115)

Local Inline Meter with NPT Ends

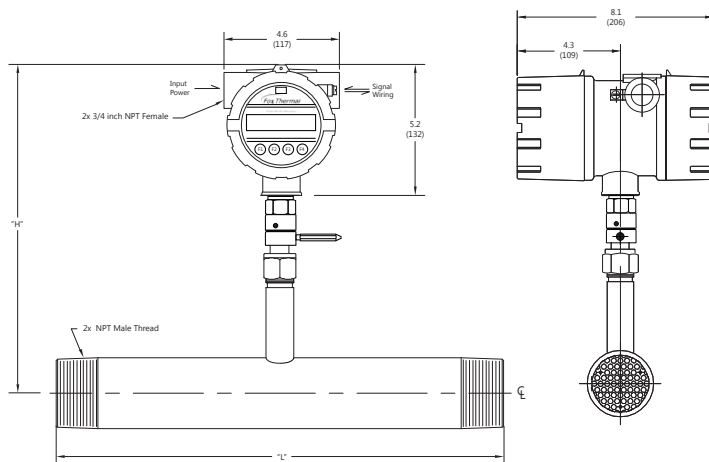

Dimensions		
Pipe Size	"L" Dim, In	"H" Dim, In (mm)
0.75"	12.0	11.9 (302)
1.00"	12.0	11.9 (302)
1.25"	12.0	11.9 (302)
1.50"	12.0	13.9 (353)
2.00"	12.0	13.9 (353)
2.50"	18.0	13.9 (353)
3.00"	18.0	13.9 (353)

Local Inline Meter with 150lb Flanges

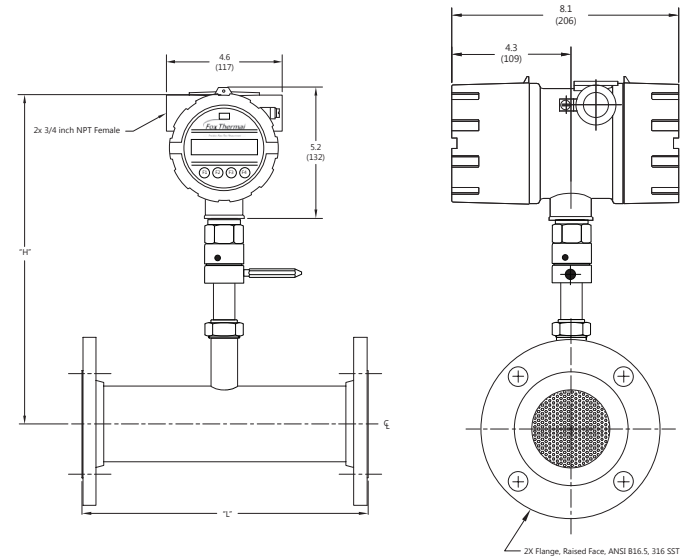

Dimensions		
Pipe Size	"L" Dim, In	"H" Dim, In (mm)
0.75"	12.0	11.9 (302)
1.00"	12.0	11.9 (302)
1.25"	12.0	11.9 (302)
1.50"	12.0	13.9 (353)
2.00"	12.0	13.9 (353)
2.50"	18.0	13.9 (353)
3.00"	18.0	13.9 (353)
4.00"	18.0	13.9 (353)
6.00"	24.0	13.9 (353)

Remote Styles

Remote Insertion Meter

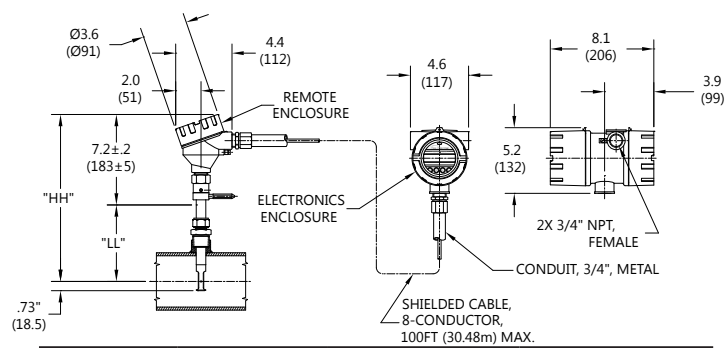

Dimensions			
Model Code	Probe Length	"LL" Dim, In (mm)	"HH" Dim, In (mm)
06I	6"	6.0 (152)	13.2 (335)
09I	9"	9.0 (229)	16.2 (411)
12I	12"	12.0 (305)	19.2 (488)
15I	15"	15.0 (381)	22.2 (564)
18I	18"	18.0 (457)	25.2 (640)
24I	24"	24.0 (610)	31.2 (792)
30I	30"	30.0 (762)	37.2 (945)
36I	36"	36.0 (914)	43.2 (1097)

Remote Insertion Meter with Retractor

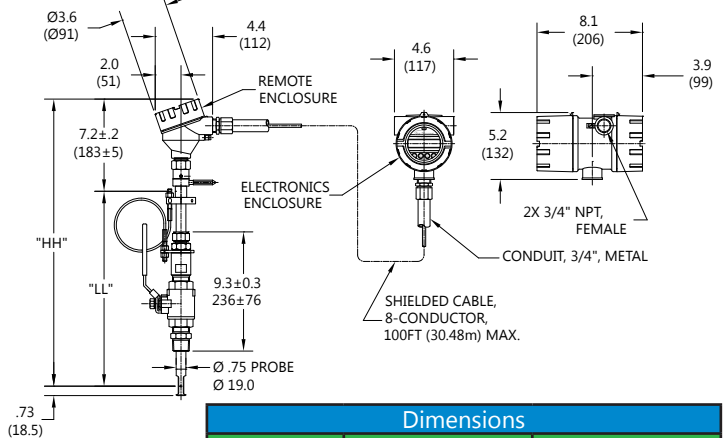

Dimensions		
Retractor	"LL" Dim, In (mm)	"HH" Dim, In (mm)
15R	15.0 (381)	22.2 (564)
18R	18.0 (457)	25.2 (640)
24R	24.0 (610)	31.2 (792)
30R	30.0 (762)	37.2 (945)
36R	36.0 (914)	43.2 (1097)

Remote Inline Meter with NPT Ends

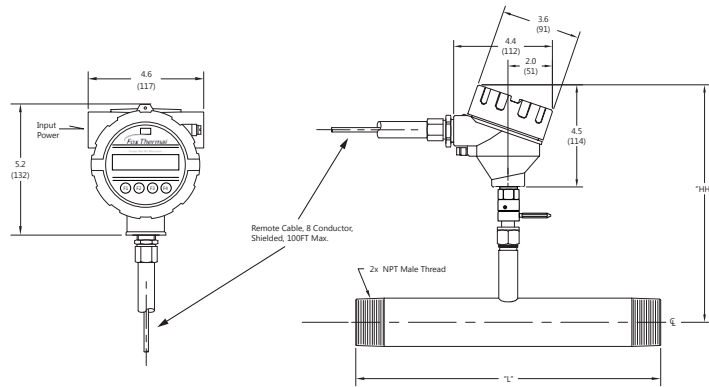

Remote Inline Meter with 150lb Flanges

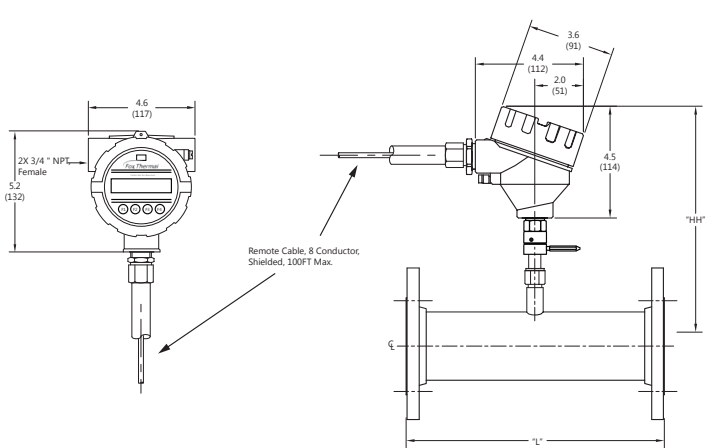

Remote Mounting Kit

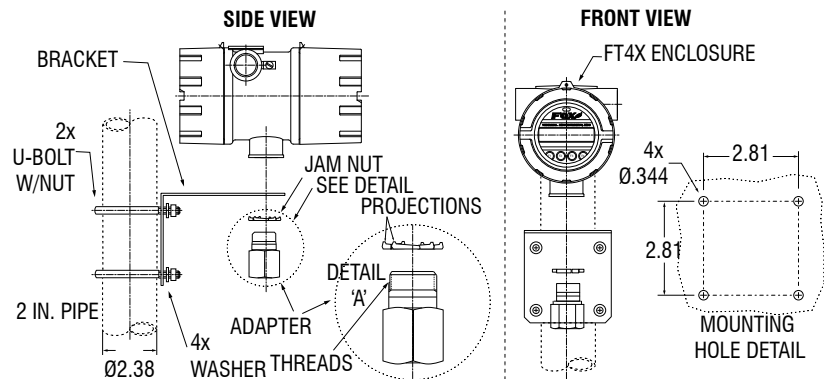

Dimensions (Remote Inline NPT)		
Pipe Size	"L" Dim, In	"H" Dim, In (mm)
0.75"	12.0	11.2 (284)
1.00"	12.0	11.2 (284)
1.25"	12.0	11.2 (284)
1.50"	12.0	13.2 (335)
2.00"	12.0	13.2 (335)
2.50"	18.0	13.2 (335)
3.00"	18.0	13.2 (335)

Dimensions (Remote Inline 150lb Flange)		
Pipe Size	"L" Dim, In	"H" Dim, In (mm)
0.75"	12.0	11.2 (284)
1.00"	12.0	11.2 (284)
1.25"	12.0	11.2 (284)
1.50"	12.0	13.2 (335)
2.00"	12.0	13.2 (335)
2.50"	18.0	13.2 (335)
3.00"	18.0	13.2 (335)
4.00"	18.0	13.2 (335)
6.00"	24.0	13.2 (335)

Inline flow meter features also available:

- 300lb flanges
- Carbon steel flow bodies

COMPARISONS

Why Choose Fox Thermal Mass Flow Meters Over Other Technologies?

For customers searching for a lower cost, higher accuracy low flow measurement meter, thermal mass flow meters by Fox Thermal beat DP meters and the other flow technologies on the market today. Compare the new Model FT4X Thermal Mass Flow Meter equipped with the state-of-art DDC-Sensor™ technology, new expanded Gas-SelectX® gas selection menu, and a standard Data Logger with date and time stamp as the alternative to other technologies. Take a look at the other benefits Fox Thermal gas mass flow meters offer over other flow measurement technologies...

	Other Technologies	Model FT4X Thermal Mass Flow
Flow Measurement of gases	Other technologies require multiple instruments to determine the volumetric flow rate at reference conditions.	Direct mass flow measurement of air and gases in standard volumetric units (ie MSCFD, SCFM, or NM3/H) or mass units (ie LBS/M or KG/H). Each meter has the option for the user to select a variety of flow units (see Operating Specs on p. 8).
Pressure or temperature compensation	Differential pressure flow meters require pressure and temperature compensation.	No additional pressure or temperature compensation is required. This is a time and cost saving measure. No additional calculations or equipment are needed to calculate flow because the meter measures the mass flow rate.
Turndown	Vortex meters are only suitable for very high flow rates. DP meters do not have good turndown.	Repeatability and exceptionally broad measurement range: up to 1000:1 (100:1 typical). Whether the flow is at a very high or low velocity, Fox Thermal mass flow meters can measure it.
Pressure Drop	If a DP meter is used to measure low velocity flow, a very small orifice is required resulting in high pressure drop.	Low pressure drop. The pressure drop of a thermal mass flow meter is negligible.
Moving Parts	A meter with moving parts, like a Turbine meter, will need regular maintenance.	No moving parts which means no problems with wear, binding, etc.
Price	Ultrasonic meters are especially expensive.	Cost effective. Thermal mass flow meters offer a low cost alternative.
Installation	Some meter technologies are complicated and difficult to install, require additional equipment, or long straight pipe run requirements.	Easy to install with insertion and inline configurations. Insertion meters are easy to install, inline meters come equipped with flow conditioners to help reduce the straight run requirements. Communication options available and intrinsic to meter electronics.
Operation	Most manufacturers build meters for a single purpose, gas calibration, or application. The customer must sift through pages of specs to find the right meter for their application. This is time consuming and ineffective.	Microprocessor based, field rangeable electronics. FOX pioneered the use of microprocessors in thermal mass flow meters and continues to create innovative solutions to measurement needs across many industries and applications. Gas-SelectX®, available in the Model FT4X, allows the user to change the gas selection in the field. Displays with configuration panels and free software allow users to interact and program the meter in the field. Using the online Product Configurator, the customer can enter process data into the system for an instant FOX Product recommendation: no need to search a list of meters for the one that's right for you!

Approvals

CE Mark: Approved
 EMC Directive: 2014/30/EU
 Emissions and Immunity Testing: EN61326-1:2013
 Pressure Equipment Directive: 97/23/EC
 Weld Testing: EN ISO 15614-1, EN ISO 9606-1, ASME B31.3

FM (FM17US0061X) & FMc (FM17CA0032X): Approved
 Class I, Division 1, Groups B, C, D;
 Class II, Division 1, Groups E, F, G;
 Class III, Division 1; T6 or T4, Ta = -40° to 70°C;
 Class 1, Zone 1, AEx/Ex db IIB + H2 T6 or T4 Gb; Ta = -20°C to 70°C; Type 4X, IP67

ATEX (FM17ATEX0015X): Approved
 II 2 G Ex db IIB + H2 T6 or T4 Gb Ta = -20°C to +70°C; IP67
 II 2 D Ex tb IIIC T85°C or T135°C Db Ta = -20°C to +70°C; IP67

IECEX (IECEX FMG 17.0008X): Approved
 Ex db IIB + H2 T6 or T4 Gb Ta = -20°C to +70°C; IP67
 Ex tb IIIC T85°C or T135°C Db Ta = -20°C to +70°C; IP67

ATEX and IECEX Standards:
 EN 60079-0:2012 + A11:2013 IEC 60079-0:2011
 EN 60079-1:2014 IEC 60079-1:2011
 EN 60079-31:2014 IEC 60079-31:2013
 EN 60529:1991 + A1:2000 IEC 60529:2001

Enclosure/Power	Divisions (All)		Zones (Gas)		Zones (Dust)	
	Main Enclosure	Remote	Main Enclosure	Remote	Main Enclosure	Remote
E1	T4	N/A	T4	N/A	T135°C	N/A
E3	T6	T4	T6	T4	T85°C	T135°C

Temperature code ratings for Zones are dependent on external process temperature factors and equipment enclosure configuration. See the above for specific temperature code ratings.

NOTE! The EU Pressure Equipment Directive (PED) requires that the minimum ambient and fluid temperature rating for carbon steel flow bodies not be below -29°C

CONFIGURATIONS

Choose Your Meter's Features

The FT4X is available in insertion, inline, and remote styles. The insertion meter is easily installed with a weld-o-let and compression fitting and requires straight pipe runs of 15D upstream/10D downstream. The inline model is available

in 3/4" to 6" sizes and includes built-in flow conditioners that eliminate the need for long, straight pipe runs. Straight run requirements are decreased to 8D upstream/4D downstream for the inline style meters. In a remote configuration, the electronics can be mounted up to 100' from the sensor.

Feature 1A : Insertion Sensor (316 SS wetted parts)	
06I	Insertion meter with 6-inch probe
09I	Insertion meter with 9-inch probe
12I	Insertion meter with 12-inch probe
15I	Insertion meter with 15-inch probe
18I	Insertion meter with 18-inch probe
24I	Insertion meter with 24-inch probe
30I	Insertion meter with 30-inch probe
36I	Insertion meter with 36-inch probe
15R*	15" Probe w/ 125 PSI retractor & full port valve - 3/4" male NPT
18R*	18" Probe w/ 125 PSI retractor & full port valve - 3/4" male NPT
24R*	24" Probe w/ 125 PSI retractor & full port valve - 3/4" male NPT
30R*	30" Probe w/ 125 PSI retractor & full port valve - 3/4" male NPT
36R*	36" Probe w/ 125 PSI retractor & full port valve - 3/4" male NPT

Feature 1B : Inline Flow Body (316 Stainless steel flowbody)			
075P	0.75 inch, male npt ends 12" Face-to-face		
10P	1 inch, male npt ends 12" Face-to-face		
125P	1.25 inch, male npt ends 12" Face-to-face		
15P	1.5 inch, male npt ends 12" Face-to-face		
20P	2 inch, male npt ends 12" Face-to-face	20PC**	CS
25P	2.5 inch, male npt ends 18" Face-to-face	25PC**	CS
30P	3 inch, male npt ends 18" Face-to-face	30PC**	CS
075F	0.75 inch, 150# RF flanges 12" Face-to-face		
10F	1 inch, 150# RF flanges 12" Face-to-face		
125F	1.25 inch, 150# RF flanges 12" Face-to-face		
15F	1.5 inch, 150# RF flanges 12" Face-to-face		
20F	2 inch, 150# RF flanges 12" Face-to-face	20FC**	CS
25F	2.5 inch, 150# RF flanges 18" Face-to-face	25FC**	CS
30F	3 inch, 150# RF flanges 18" Face-to-face	30FC**	CS
40F	4 inch, 150# RF flanges 18" Face-to-face	40FC**	CS
60F	6 inch, 150# RF flanges 24" Face-to-face	60FC**	CS
15G	1.5 inch, 300# RF flanges 12" Face-to-face		
20G	2 inch, 300# RF flanges 12" Face-to-face	20GC**	CS
25G	2.5 inch, 300# RF flanges 18" Face-to-face	25GC**	CS
30G	3 inch, 300# RF flanges 18" Face-to-face	30GC**	CS
40G	4 inch, 300# RF flanges 18" Face-to-face	40GC**	CS
60G	6 inch, 300# RF flanges 24" Face-to-face	60GC**	CS

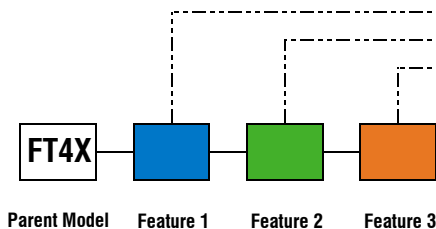

NOTE! All inline flowbodies are schedule 40 pipes

*The high pressure retractor requires a 1" female NPT for mounting
 **Same sizing, but constructed with A106 Grade B Carbon Steel (CS) pipe
 ***100' max, cable optional

Feature 2: Enclosure and Power	
E1	Local NEMA 4X enclosure, 24VDC powered
E3***	Remote with explosion-proof J-box, 24VDC powered

Feature 3: Communication Options	
B0	No communication option
RS	RS485 Modbus MS/TP
BH	HART on primary 4-20mA output

SPECIFICATIONS

Performance Specs

Flow Accuracy:

- Air: ±1% of reading ±0.2% of full scale
- Other gases: ±1.5% of reading ±0.5% of full scale
- Accuracy specification applies to customer's selected flow range
- Maximum range: 15 to 60,000 SFPM (0.07 to 280 NMPS)
- Minimum range: 15 to 500 SFPM (0.07 to 2.35 NMPS)
- Straight, unobstructed pipe requirement:
- Insertion: 15 diameters upstream, 10 downstream
- Inline: 8 diameters upstream, 4 downstream

Gross Heating Value Uncertainty:

±0.01% on mass basis; ±1.0% on volume basis

Flow Repeatability: ±0.2% of full scale

Flow Response Time: 0.8 seconds (one time constant)

Temperature Accuracy: ±1° F (±0.6° C)

Calibration:

- Factory Calibration to NIST traceable standards
- CAL-V™: In-situ, operator-initiated calibration validation

Operating Specs

Gas-SelectX® Gas Selections:

Pure Gas, Mixed Gas, and Oil & Gas Mixed Gas Menus to suit any application. See the Fox Thermal website for more information on availability of current gases.

Units of Measurement (field-selectable):

SCFM, SCFH, NM3/M, NM3/H, NM3/D, NLPS, NLPM, NLPH, MCFD, MSCFD, SCFD, MMSCFD, SM3/D, SM3/H, SM3/M, LB/S, LB/M, LB/H, LB/D, KG/S, KG/M, KG/H, SLPM, MT/H

Flow Velocity Range: 15 to 60,000 SFPM (0.07 to 280 NMPS)

Turndown: up to 1000:1; 100:1 typical

Flow Ranges - Insertion Meters			
Pipe Diameter	SCFM	MSCFD	NM3/Hr
1.5" (40mm)	0 - 840	0 - 1,220	0 - 1,325
2" (50mm)	0 - 1,400	0 - 2,020	0 - 2,210
2.5" (63mm)	0 - 2,000	0 - 2,880	0 - 3,150
3" (80mm)	0 - 3,100	0 - 4,440	0 - 4,890
4" (100mm)	0 - 5,300	0 - 7,650	0 - 8,360
6" (150mm)	0 - 12,000	0 - 17,340	0 - 18,930
8" (200mm)	0 - 20,840	0 - 30,020	0 - 32,870
10" (250mm)	0 - 32,800	0 - 47,250	0 - 51,740
12" (300mm)	0 - 46,600	0 - 67,180	0 - 73,500

NOTE! To determine if the FT4X will operate accurately in other pipe sizes, divide the maximum flow rate by the pipe area. The application is acceptable if the resulting velocity is within the velocity range above. Check Fox Thermal website for velocity calculator.

Flow Ranges - Inline Meters			
Pipe Diameter	SCFM	MSCFD	NM3/Hr
0.75"	0 - 220	0 - 320	0 - 350
1"	0 - 360	0 - 520	0 - 570
1.25"	0 - 625	0 - 900	0 - 990
1.5"	0 - 840	0-1,220	0 - 1,325
2"	0 - 1,400	0-2,020	0 - 2,210
2.5"	0 - 2,000	0-2,880	0 - 3,150
3"	0 - 3,100	0-4,440	0 - 4,890
4"	0 - 5,300	0-7,650	0 - 8,360
6"	0 - 12,000	0-17,340	0 - 18,930

NOTE! Consult factory for flow ranges above those listed. Inline meters above 5,000 SCFM (7,900 NM3/H) air may require third party calibration. Contact Fox Thermal.

Temperature:

- DDC-Sensor™: -40 to 250°F (-40 to 121°C)
- Enclosure: -40 to 158°F (-40 to 70°C)*
- Remote Sensor Enclosure: -40 to 158°F (-40 to 70°C)
- ***NOTE!** Display dims below -4°F (-20°C); function returns once temperature rises again.

Relative Humidity: 90% RH maximum; non-condensing

NOTE! Condensing liquids contacting the sensor can cause erratic flow indication.

Gas Pressure (maximum; at 100°F):

- Insertion meter: 740 psig (51.02 barg)
- 316 SS inline w/NPT ends: 500 psig (34.5 barg)
- 316 SS inline w/150lb flanges: 230 psig (16 barg)
- 316 SS inline w/300lb flanges: 600 psig (41 barg)
- CS inline w/NPT ends: 300 psig (21 barg)
- CS inline w/150lb flanges: 285 psig (20 barg)
- CS inline w/300lb flanges: 740 psig (51 barg)
- Retractor: 150 psig (10.3 barg) max.
- Check with factory for higher pressure options.
- When teflon ferrule option ordered, gas pressure is 60psig (4.1 barg) maximum.
- Pressure ratings stated for temperature of 100°F (38°C).

Input power: 12 to 28 VDC, 6 watts max.

Full input power range: 10 to 30 VDC.

A 20 Watt or greater power supply is recommended to power the FT4X

Class I Equipment (Electrical Grounding Required for Safety).

Installation (Over-voltage) Category II for transient over-voltages.

Inputs/Outputs:

4-20mA Channel 1:

- Standard isolated 4-20mA output configured to indicate for flow; fault indication per NAMUR NE43. HART communication option.
- The 4-20mA load resistance must be 125 ohms or less when operating on 12 volt power and 600 ohms or less on 24 volt power.

4-20mA Channel 2:

- Standard isolated 4-20mA output configured to indicate either flow or temperature.

Pulse/Alarm:

- Isolated open collector output rated for 5 to 24VDC, 20mA maximum load, 0 to 100Hz (the pulse output can be configured to either transmit a 0 to 100Hz signal proportional to flow rate or an on/off alarm).

Remote Switch Input:

- Can be configured to reset the flow totalizer and elapsed time.

Serial Communication:

- Isolated RS485 Modbus RTU option
- Isolated HART communication option

USB Communication:

- Isolated USB 2.0 for interfacing with a laptop or computer is standard.
- FT4X View™: A free PC-based software tool that provides complete configuration, remote process monitoring, and data logging functions through USB communication.

4-20mA and Loop Verification:

Simulation mode used to align 4-20mA output with the input to customer's PLC/DCS.

Physical Specs

Probe diameter: ¾"

Sensor Material: 316 stainless steel

Enclosure: NEMA 4X (IP67), aluminum, dual ¾" FNPT conduit entries.

Cabling to remote enclosure: 8-conductor, 18 AWG, twisted pair, shielded, 100 feet maximum.

Insertion flow meter installation: Fox-supplied compression fitting connects to customer-supplied 1" female coupling welded to pipe. Fox recommends the following probe lengths (without insulation):

Pipe Diameter	Probe Length
1.5" (40mm) to 6" (150mm)	6-inch
8" (200mm) to 12" (300mm)	9-inch
14" (350mm) to 18" (450mm)	12-inch

Probe Lengths (LL*) in inches(cm) =

6.0 (15.2)	9.0 (22.9)	12.0 (30.5)
15.0 (38.1)	18.0 (45.7)	24.0 (61.0)
30.0 (76.2)	36.0 (91.4)	

*See dimensional drawings on pages 4 and 5.

Equation for selecting flow meter probe length:

Probe length = ½ pipe ID (inches) + 3" + 10" (for retractor, if any) + thickness of insulation (if any). Round up to the next standard probe length available.